

## MDT 569 M32

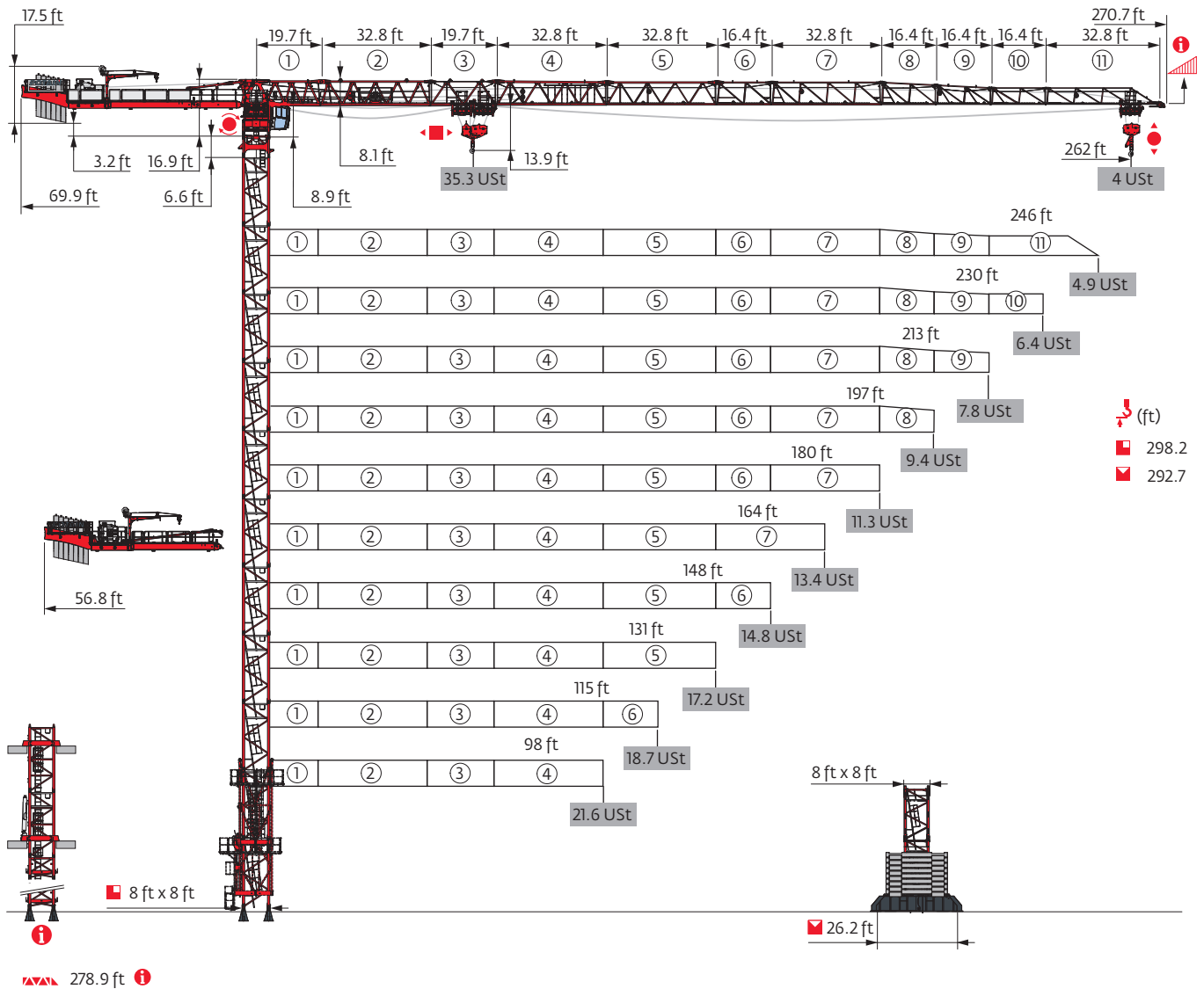

Potain Plus



Power Control

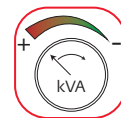

Top Site



Anti-collision systems

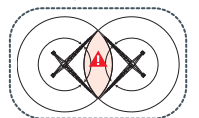

Mast - Reactions

8 ft - P 800B											
Height (ft)	98	115	131	148	164	180	197	213	230	246	262
Height (ft)	232.6	227	227	227	221.8	216.2	216.2	216.2	216.2	216.2	205.4
Height/P <sub>r</sub> (ft)	232.6	227	227	227	221.8	216.2	216.2	216.2	216.2	216.2	205.4
Mast Section	6.6 ft	1	1	1	1	1	1	1	1	1	1
	10.9 ft	0	1	1	1	2	0	0	0	0	2
	16.4 ft	14	13	13	13	12	13	13	13	13	11
F2 (Ust)	● 293	289	289	295	287	284	285	283	278	269	268
	■ 352	334	338	347	330	325	330	332	347	355	334
F3 (Ust)	● 189	182	180	183	173	175	175	174	168	160	158
	■ 266	244	246	252	234	233	237	240	254	263	241

8 ft - P 854A											
Height (ft)	98	115	131	148	164	180	197	213	230	246	262
Height (ft)	292.7	298.2	298.2	287.4	292.7	292.7	292.7	292.7	287.4	281.8	281.8
Height/P <sub>r</sub> (ft)	292.7	298.2	292.7	287.4	287.4	287.4	287.4	287.4	287.4	281.8	281.8
Mast Section	6.6 ft	1	1	1	1	1	1	1	1	1	1
	10.9 ft	1	0	0	2	1	1	1	2	0	0
	16.4 ft	17	18	18	16	17	17	17	16	17	17
F2 (Ust)	● 365	372	369	368	363	367	368	364	366	351	366
	■ 603	626	624	601	601	615	615	610	610	586	593
F3 (Ust)	● 243	245	240	238	232	240	240	237	239	227	240
	■ 500	517	513	489	487	505	505	500	500	479	485

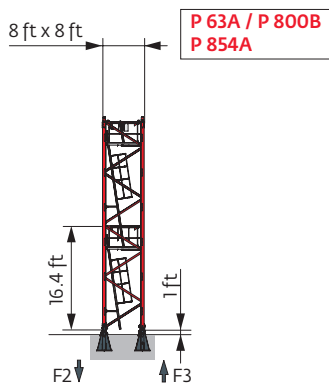



Note: When "ASCE" is noted in this data sheet it is referring to 115 mph Wind Zone, Exposure B, Design Wind Speed = 98 mph. See back cover for design wind speed calculations.

**i** Motorized accesses: adapted mast compositions, base ballast and reactions.

Other mast compositions - Please consult us

**8 ft - ZY 800 - **

$\Delta/\Delta$ (ft)	98	115	131	148	164	180	197	213	230	246	262
$\Delta$ (ft)	215.2	220.8	220.8	220.8	215.2	215.2	215.2	209.7	209.7	209.7	198.8
$\Delta/P_r$ (ft)	215.2	215.2	209.7	204.4	198.8	182.4	198.8	209.7	209.7	209.7	198.8
	6.6 ft	1	1	1	1	1	1	1	1	1	1
	10.9 ft	1	0	0	0	1	1	1	2	2	1
	16.4 ft	12	13	13	13	12	12	12	11	11	11
FI (Ust)	● 157	162	162	165	159	158	158	158	160	156	153
	■ 142	143	146	152	140	152	155	150	160	166	148

**8 ft - ZY 854 - **

$\Delta/\Delta$ (ft)	98	115	131	148	164	180	197	213	230	246	262
$\Delta$ (ft)	287.1	292.7	292.7	287.1	287.1	287.1	281.8	276.3	281.8	276.3	265.4
$\Delta/P_r$ (ft)	287.1	292.7	287.1	287.1	287.1	281.8	281.8	276.3	281.8	276.3	265.4
	6.6 ft	1	1	1	1	1	1	1	1	1	1
	10.9 ft	0	2	2	0	0	0	1	2	1	2
	16.4 ft	17	16	16	17	17	17	16	15	16	15
FI (Ust)	● 228	234	236	239	235	231	233	223	232	227	217
	■ 296	312	313	314	308	305	307	290	311	308	281

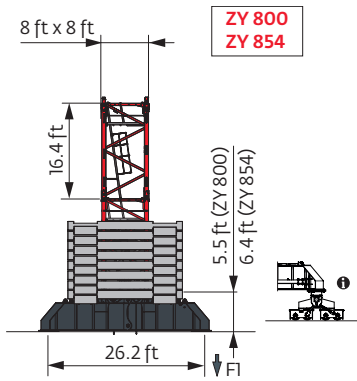

Anchorage



Base ballast

(Ust) / 8 ft - ZY 800 -											
ΔΔΔ (ft)	98	115	131	148	164	180	197	213	230	246	262
220.8		92.6	79.4	66.1							
215.2	79.4	79.4	66.1	66.1	66.1	66.1	66.1				
209.7	79.4	79.4	66.1	66.1	66.1	66.1	66.1	79.4	92.6	92.6	
198.8	66.1	66.1	66.1	52.9	52.9	52.9	52.9	79.4	92.6	92.6	92.6
182.4	52.9	66.1	52.9	52.9	52.9	52.9	52.9	66.1	92.6	92.6	92.6
166	52.9	52.9	52.9	39.7	39.7	52.9	52.9	66.1	79.4	92.6	92.6
149.6	39.7	52.9	39.7	39.7	39.7	52.9	52.9	66.1	79.4	79.4	92.6
133.2	39.7	39.7	39.7	39.7	39.7	52.9	52.9	66.1	79.4	79.4	79.4
116.8	39.7	39.7	39.7	39.7	39.7	39.7	52.9	66.1	79.4	79.4	79.4
100.4	39.7	39.7	39.7	39.7	39.7	39.7	52.9	66.1	66.1	66.1	66.1
84	39.7	39.7	39.7	39.7	39.7	39.7	52.9	66.1	66.1	66.1	66.1
67.6	39.7	39.7	39.7	39.7	39.7	39.7	52.9	66.1	66.1	66.1	66.1

(Ust) / 8 ft - ZY 854 -											
ΔΔΔ (ft)	98	115	131	148	164	180	197	213	230	246	262
292.7		211.6	211.6								
287.1	211.6	185.2	198.4	211.6	198.4	211.6					
281.8	185.2	172	172	185.2	172	198.4	211.6		211.6		
276.3	172	158.7	158.7	172	158.7	185.2	185.2	185.2	211.6	211.6	
265.4	132.3	119.1	119.1	132.3	119.1	145.5	145.5	145.5	172	185.2	185.2
249	105.8	105.8	92.6	92.6	92.6	105.8	105.8	105.8	119.1	132.3	132.3
232.6	92.6	92.6	79.4	79.4	66.1	79.4	79.4	79.4	92.6	92.6	92.6
216.2	79.4	66.1	66.1	66.1	52.9	66.1	66.1	66.1	79.4	92.6	92.6
199.8	66.1	66.1	52.9	52.9	52.9	52.9	52.9	66.1	79.4	79.4	92.6
183.4	52.9	52.9	52.9	39.7	39.7	39.7	52.9	66.1	79.4	79.4	79.4
167	39.7	52.9	39.7	26.5	39.7	39.7	39.7	66.1	79.4	79.4	79.4
150.6	39.7	39.7	39.7	26.5	39.7	39.7	39.7	66.1	79.4	79.4	79.4
134.2	26.5	39.7	26.5	26.5	26.5	39.7	39.7	52.9	66.1	66.1	66.1
117.8	26.5	26.5	26.5	26.5	26.5	39.7	39.7	52.9	66.1	66.1	66.1
101.4	26.5	26.5	26.5	26.5	26.5	26.5	39.7	52.9	66.1	66.1	66.1
85	26.5	26.5	26.5	26.5	26.5	26.5	39.7	52.9	52.9	52.9	52.9
68.6	26.5	26.5	26.5	26.5	26.5	26.5	39.7	52.9	52.9	52.9	52.9

Counter-jib ballast

ΔΔΔ	14,551 lb	10,362 lb	Ust (lb)
262 ft	6	0	87,303
246 ft	5	1	83,114
230 ft	5	1	83,114
213 ft	5	1	83,114
197 ft	4	2	78,925
180 ft	3	3	74,737
164 ft	7	0	101,854
148 ft	5	2	93,476
131 ft	6	0	87,303
115 ft	4	2	78,925
98 ft	4	1	68,564

CCP - 14,551 lb

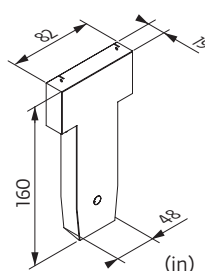



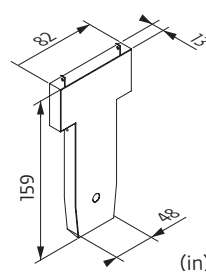

CCQ - 10,362 lb







Load curves



 (ft)		39	66	82	98	105	115	121	131	138	148	154	164	171	180	187	197	203	213	220	230	236	246	253	262	ft		
	35.3 USt			17.6 USt																								
262	13.8 → 43 13.8 → 46.6	75.2 - 82.3 80.8 - 88.6	35.3 21 35.3 23.1	17.6 17.6	14.2 13.2 15.7 14.5	11.8 11 12.1 10.9	9.9 9.3 10.3 9.4	8.5 8.1 8.9 8.1	7.4 7 7.7 7.1	6.5 6.2 6.8 6.3	5.7 5.5 6 5.6	5.1 4.9 5.3 5	4.5 4.3 4.8 4.5	4.1 3.9 4.3 4	3.6 USt USt P+													
246	13.8 → 44.6 13.8 → 48.2	78.3 - 85.4 84.2 - 91.9	35.3 22.1 35.3 24.3	17.6 18.3	14.9 13.8 15.2 13.6	12.4 11.5 12.7 11.5	10.9 10.9 10.9 9.4	9.9 9.4 8.7 8.2	9 8.5 8.2 7.6	7.5 6.9 7.3 6.7	6.6 6.4 6.4 6	5.9 5.8 5.2 5.4	5.5 5.2 5.4 5.2	4.9 4.7 4.9 USt P+														
230	13.8 → 50.2 13.8 → 54.5	88.8 - 96.6 95.7 - 105	35.3 25.7 35.3 28.2	19.5 21.4	17.3 16 17.6 17.6	14.4 13.5 15.8 14.8	12.3 11.6 12.7 11.7	10.6 10.1 11.1 10.2	9.3 8.9 9.7 9	8.2 7.9 8.6 8	7.9 7.3 7.6 7.1	6.6 6.3 6.8 6.4	6 USt USt P+															
213	13.8 → 55.1 13.8 → 59.7	97.5 - 106.1 105.1 - 114.8	35.3 28.7 35.3 31.5	21.9 24.1	17.6 17.6 19.2 17.7	16.1 15.1 16.6 15.1	13.7 13 12.9 12.2	11.9 11.3 12.2 11.3	10.5 10 10.6 9.9	9.3 8.9 8.7 8.3	8 7.5 8.3 7.8	USt USt P+																
197	13.8 → 58.7 13.8 → 60.4	103.9 - 113.1 112 - 120.7	35.3 30.9 35.3 32.4	23.6 25.4	18.9 17.6 20.6 19.1	17.3 16.2 17.5 16.1	14.8 14 15.2 13.9	12.9 12.2 13.2 12.1	11.3 10.8 11.5 10.6	10.1 9.6 10.1 9.4	9 USt USt P+																	
180	13.8 → 60.4 13.8 → 61.4	107.1 - 116.6 113.8 - 122.2	35.3 32 35.3 32.9	24.5 25.8	19.6 18.1 20.9 19.4	17.6 16.8 17.6 16.3	15.4 14.5 15.4 14.3	13.4 12.7 13.6 12.6	12.7 11.8 12.1 11.3	10.5 USt USt P+																		
164	13.8 → 64 13.8 → 64.3	113.8 - 123.9 120 - 128.6	35.3 34.3 35.3 34.6	26.4 27.2	21.1 20.6 22.1 20.6	19.5 18.6 17.6 17.2	16.5 15.6 16.3 15.1	14.4 13.6 15.1 14.4	13.6 12.7 USt USt P+																			
148	13.8 → 64.3 13.8 → 64.3	114.3 - 124.7 117.4 - 126	35.3 34.5 35.3 34.5	26.5 26.6	21.2 20.1 21.7 20.1	19.6 18.1 17.6 16.9	16.6 15.7 16 14.8	15.7 14.4 USt USt P+																				
131	13.8 → 64.6 13.8 → 65	114.7 - 124.8 119.8 - 128.7	35.3 34.6 35.3 34.8	26.6 27.4	21.3 20.6 22.2 20.6	19.7 18.5 17.6 17.2	16.6 USt USt P+																					
115	13.8 → 65.9 13.8 → 65.9		35.3 35.3 35.3 35.3	27.3 27.6	21.9 20.2 22.4 20.8	18.1 USt USt P+																						
98	13.8 → 64 13.8 → 64		35.3 34.3 35.3 34.3	26.4 26.6	21.2 USt 21.6 USt P+																							

 =  - 2.18 USt max.















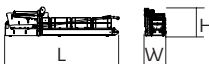
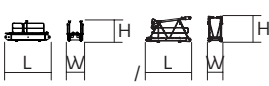
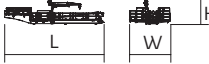

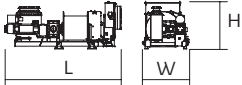



 (ft)		39	66	82	98	105	115	121	131	138	148	154	164	171	180	187	197	203	213	220	230	236	246	253	262	ft	
	35.3 USt			17.6 USt																							
262	11.2 → 43 11.2 → 46.3	74.4 - 76.1 80 - 82	35.3 20.8 35.3 22.9	16 17.6	12.5 11.4 13.9 12.8	10.1 10.1 10.7 9.9	9.3 8.2 9.2 8.6	7.6 6.8 7.7 7.2	6.8 6.3 6.4 6	5.7 5.3 5.4 5.1	4.8 4.5 4.6 4.3	4 3.7 3.9 3.6	3.1 2.8 3.3 3.1	2.6 2.35 2.55 2.3	1.95 USt USt P+												
246	11.2 → 44.3 11.2 → 47.9	77.5 - 79.2 83.4 - 85.3	35.3 21.8 35.3 24	18 18	16.9 14.8 13.6 12	12.2 11.1 11.9 9.9	10.7 9.9 9.2 8.3	8.9 8.2 8.3 7.8	7.4 6.9 7 6.6	6.2 5.8 6 5.6	5.3 5 5.1 4.8	4.5 4.4 4.1 3.8	3.8 3.5 3.2 USt P+														
230	11.2 → 49.9 11.2 → 53.8	87.1 - 89.1 93.9 - 96.6	35.3 25.2 35.3 27.8	19.1 21	15.5 14.3 17.3 15.9	12.7 11.7 14.1 13.1	10.5 9.8 11.8 11	9.8 8.9 9.3 8.5	8.3 7.6 8 7.3	7.1 6.5 6.8 6.2	6.1 5.6 5.9 5.4	5.3 4.9 5.1 4.6	4.2 USt USt P+														
213	11.2 → 54.8 11.2 → 59.4	96.6 - 98.8 104.1 - 106.9	35.3 28.5 35.3 31.3	21.7 23.9	17.6 16.3 17.6 16.2	14.6 13.6 15.1 13.5	12.2 11.4 12.6 11.4	10.4 9.8 10.7 9.7	9 8.5 9.1 8.3	7.8 7.4 7.9 7.2	6.5 6 6.8 6.3	6 USt USt P+															
197	11.2 → 58.4 11.2 → 60	102.9 - 105.3 110.9 - 112.2	35.3 30.7 35.3 32.2	23.4 25.2	18.7 18.9 20.4 18.9	17.6 17.2 16 14.5	14.7 13.7 12.4 11.6	13.2 12.4 12.6 11.6	11.4 10.7 10.6 10	9.8 9.1 8.6 7.9	8.6 8.1 7.5 USt P+																
180	11.2 → 60.4 11.2 → 61.4	107.1 - 109.6 113.8 - 114.9	35.3 32 35.3 32.9	24.5 25.8	19.6 18.1 20.9 19.4	16.6 16.5 15 14.1	14.1 13 13 12.3	12.1 11.4 13 11.3	10.5 9.9 10.8 10	9.2 USt USt P+																	
164	11.2 → 64 11.2 → 64.3	113.8 - 116.5 120 - 120.9	35.3 34.3 35.3 34.6	26.4 27.2	21.1 20.6 22.1 20.6	19.5 18.6 17.6 15.9	16.8 15.2 15 13.8	14.3 13.1 13.1 USt P+	12.3 11.4 USt																		
148	11.2 → 64.3 11.2 → 64.3	114.3 - 116.9 117.4 - 118.5	35.3 34.5 35.3 34.5	26.5 26.6	21.2 20.1 21.7 20.1	19.6 18.1 17.1 15.6	16.8 15.3 14.7 13.5	14.4 13.1 USt USt P+																			
131	11.2 → 64.6 11.2 → 65	114.7 - 117.4 119.8 - 121	35.3 34.6 35.3 34.8	26.6 27.4	21.3 20.6 22.2 20.6	19.7 18.5 17.6 15.9	16.9 USt USt P+																				
115	11.2 → 65.9 11.2 → 65.9		35.3 35.3 35.3 35.3	27.3 27.6	21.9 20.2 22.4 20.8	18.1 USt USt P+																					
98	11.2 → 64 11.2 → 64		35.3 34.3 35.3 34.3	26.4 26.6	21.2 USt 21.6 USt P+																						

 =  - 0.71 USt max.

Dimensions and weight

Slewing crane part:  262 ft -  -  -  -  180 HPL™



Slewing crane part	L (ft)	W (ft)	H (ft)	lb (+/- 5%)	
Counter-jib		39.4	7.2	8.2	29,690
		39.4	7.2	8.2	39,432
		39.1	7.2	9.2	29,573
		15 14.2	5.3 4.5	6.6 8.1	9,590 6,993
		53.3	21.9	12.9	34,458
		66.5	21.9	12.9	43,343
Hoisting winch (+ rope)	 180 HPL™	15.8	6.3	6.5	16,698
Cab	 Ultra View	11	7.5	8.2	6,614
Towerhead	 8 ft	8.8	8.2	9.9	27,866
		21.9	8.2	9.9	34,480
Jib section	 ①	25.3	5.1	8.1	19,103
	 ②	34	7.4	8.1	19,335
	 ③	20.9	4.5	8	7,154
	 ④	34.1	4.5	7.8	9,466
	 ⑤	34.1	4.5	7.3	7,115
	 ⑦	33.6	4.5	7.2	4,991
	 ⑪	33.1	4.5	5.1	1,825
	 ⑥	17.6	4.5	7.3	3,007
	 ⑧	17.4	4.5	7	1,719
	 ⑨	17.1	4.5	6.1	1,464
 ⑩	17	4.5	5.2	1,246	

		L (ft)	W (ft)	H (ft)	Ib (+/- 5%)
Jib section		5.5	5.2	1.9	589
Trolley		8.6	5.7	5.2	2,678
Pulley block		6.2	2.6	10.4	3,120
Trolley		13.8	5.9	4.9	3,219
Pulley block		7.5	1.1	9.7	2,888
Trolley		6.9	5.9	4.9	1,720
Pulley block		5	1.1	10	1,786
Trolley inspection platform		3.1	3.4	7	125
<b>Crane tower</b>					
T 851		36.7	15.9	19	34,723
K 84/K 84-2		7.3	10.6	8.2	6,724
KRM 849B K 85/KR 84B2 KM 850.10B KM 850.14B K 85/KR 84A2 KMT 850.10A KMT 850.14A K 849A KMT 849A KR 849A KRMT 849A KRMT 849C KMT 850.10C		33.6 33.6 33.9 33.9 17.2 17.5 17.5 17.2 17.2 17.2 17.2 11.7 12	8.4 8.3 8.3 8.3 8.3 8.3 8.3 8.4 8.4 8.3 8.4 8.4 8.3	8.3 8.2 8.2 8.2 8.2 8.2 8.2 8.3 8.3 8.2 8.3 8.3 8.2	17,196 21,242 22,201 24,670 12,236 12,015 13,206 7,496 6,945 9,458 9,017 7,066 9,326
Fixing angles		2.5 3	2.5 3	4.2 4.9	1,025 2,072
1/2 Cross girder		18.6 18.7	3.2 3.2	6.3 7.4	10,406 14,176
Cross girder		39.2 39	4.6 4.7	6.3 7.4	22,212 30,865

Mechanisms

480 V - 60 Hz													hp	kW	
	180 HPL™ 80	fpm	139	172	230	358	495	71	87	115	184	248	180	132	1,660 ft
		USt	17.6	13.2	8.8	4.4	2	35.3	26.5	17.6	8.8	5.2			
	15 DVF 16 Optima	fpm	0 → 108 (35.3 USt) 0 → 164 (22 USt) 0 → 220 (11 USt) 0 → 328 (2.8 USt)												
	RVF 174 Optima +	rpm	0 → 0.7										4 x 10	4 x 7.5	

480 V (+6% -10%) 60 Hz	194 → 122 kVA

These mast combinations meet the EN 14439 and ASME B30.3-2016 specifications for "out of service" wind conditions, provided the illustrated wind speed matches required design wind speed for the location of the tower crane. The "out of service" design wind speed was determined in accordance with ASCE 7-10, Figure 26.5-1A. The wind velocity, used for this configuration was 98 mph (158 kph), which represents a nominal design 3-second wind gust at 33 ft (10 m) above ground for Exposure B category. A factor of 0.85 was applied to the 700-year ultimate design wind speed of 115 mph (185 kph), per ASCE 37-02, with the assumption that this crane is considered a temporary structure used during a construction period of 2 years or less.

- Jib elevation
- Total ballast weight
- Required power
- Standard equipment
- Lorry 44 ft
- Power Control Function: winch speeds adapted to the available power
- Options
- Container High Cube 40 ft, and/or Flat Rack 20 ft
- Consult us
- Potain Plus function: Plus load curves
- Hoisting
- Hook heights with Plus load curves
- Trolleying
- Reactions in service
- Slewing
- Reactions out of service
- Travelling

This commercial document is not legally binding. For any technical information, please refer to the corresponding instructions.

