

## MDT 569 M20

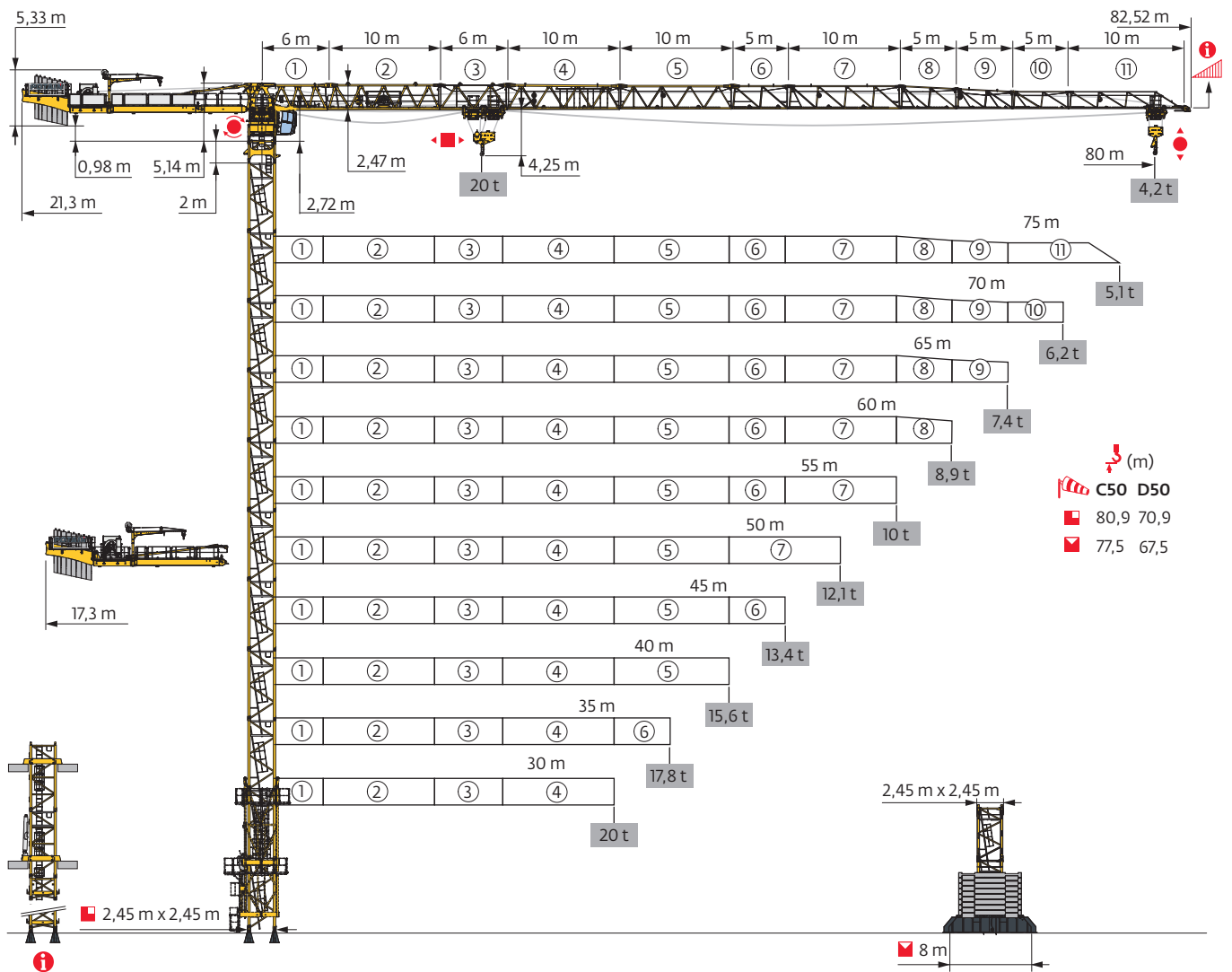

Potain Plus



Power Control

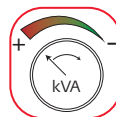

Top Site



Top Tracing 3

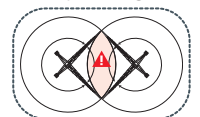

Mât - Réactions / Mast - Reaktionskräfte / Mast - Reactions / Mástil - Reacciones / Torre - Reazioni  
Tramo - Reacções / Реакция опор мачты

| 2,45 m - P 800B - C50   |        |      |      |      |      |      |      |      |      |      |      |     |
|---|--------|------|------|------|------|------|------|------|------|------|------|-----|
| ΔΔΔΔ (m)  | 30     | 35   | 40   | 45   | 50   | 55   | 60   | 65   | 70   | 75   | 80   |     |
| ↕ (m)   | 67,6   | 69,2 | 67,6 | 67,6 | 67,6 | 65,9 | 65,9 | 65,9 | 64,2 | 62,6 | 60,9 |     |
| ↕/P* (m)  | 67,6   | 69,2 | 67,6 | 67,6 | 67,6 | 65,9 | 65,9 | 65,9 | 64,2 | 62,6 | 60,9 |     |
|  | 2 m    | 1    | 1    | 1    | 1    | 1    | 1    | 1    | 1    | 1    | 1    |     |
|   | 3,33 m | 2    | 1    | 2    | 2    | 0    | 0    | 0    | 1    | 2    | 0    |     |
|   | 5 m    | 12   | 13   | 12   | 12   | 12   | 13   | 13   | 13   | 12   | 11   | 12  |
| F2 (t)  | ●      | 241  | 248  | 247  | 251  | 250  | 247  | 246  | 244  | 237  | 225  | 226 |
|   | ■      | 385  | 396  | 386  | 393  | 390  | 381  | 385  | 387  | 386  | 377  | 356 |
| F3 (t)  | ●      | 156  | 161  | 154  | 156  | 153  | 155  | 153  | 152  | 145  | 133  | 136 |
|   | ■      | 311  | 318  | 303  | 309  | 303  | 298  | 302  | 305  | 303  | 295  | 274 |
| ↕ (m) D50   | 59,2   | 59,2 | 59,2 | 59,2 | 59,2 | 57,6 | 55,9 | 55,9 | 55,9 | 54,2 | 54,2 |     |
| ↕/P* (m) D50  | 59,2   | 59,2 | 59,2 | 59,2 | 59,2 | 57,6 | 55,9 | 55,9 | 55,9 | 54,2 | 54,2 |     |



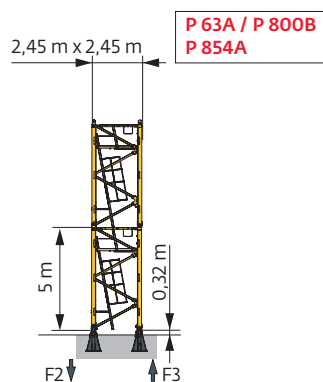

| 2,45 m - P 854A - C50  |        |      |      |      |      |      |      |      |      |      |      |     |
|--|--------|------|------|------|------|------|------|------|------|------|------|-----|
| ΔΔΔΔ (m)   | 30     | 35   | 40   | 45   | 50   | 55   | 60   | 65   | 70   | 75   | 80   |     |
| ↕ (m)  | 80,9   | 80,9 | 80,9 | 79,2 | 79,2 | 77,6 | 77,6 | 77,6 | 75,9 | 75,9 | 75,9 |     |
| ↕/P* (m)   | 80,9   | 80,9 | 80,9 | 79,2 | 79,2 | 77,6 | 77,6 | 77,6 | 75,9 | 75,9 | 75,9 |     |
|  | 2 m    | 1    | 1    | 1    | 1    | 1    | 1    | 1    | 1    | 1    | 1    |     |
|  | 3,33 m | 0    | 0    | 0    | 1    | 1    | 2    | 2    | 0    | 0    | 0    |     |
|  | 5 m    | 16   | 16   | 16   | 15   | 15   | 14   | 14   | 14   | 15   | 15   | 15  |
| F2 (t)   | ●      | 280  | 284  | 284  | 285  | 285  | 283  | 283  | 276  | 270  | 281  |     |
|  | ■      | 567  | 562  | 565  | 556  | 553  | 551  | 558  | 559  | 541  | 551  | 555 |
| F3 (t)   | ●      | 185  | 187  | 184  | 183  | 180  | 183  | 180  | 181  | 176  | 170  | 179 |
|  | ■      | 483  | 474  | 474  | 464  | 458  | 460  | 466  | 467  | 451  | 460  | 463 |
| ↕ (m) D50  | 69,2   | 70,9 | 69,2 | 69,2 | 69,2 | 67,6 | 67,6 | 67,6 | 65,9 | 65,9 | 65,9 |     |
| ↕/P* (m) D50   | 69,2   | 70,9 | 69,2 | 69,2 | 69,2 | 67,6 | 67,6 | 67,6 | 65,9 | 65,9 | 65,9 |     |







**i** Autres compositions de pylône - Nous consulter. / Andere Turmaufbauten - bitte kontaktieren Sie uns. / Other mast compositions - Please consult us. / Para otras composiciones de mástil - Por favor contáctenos. / Per altre composizioni torre, contattateci. / Para outras composições de coluna - Por favor, consulte-nos. / Для других композиций мачты пожалуйста консультируйтесь с нами.

Accès motorisés : compositions de mâture, de lest de base et réactions adaptées. / Motorisierter Zugang vom : Mastzusammensetzung, Grundballast und Reaktionskräfte sind angepasst. / Motorized accesses: adapted mast composition, base ballast and reactions. / Acceso a cabina con elevador: Adaptación de composición de mástil, lastre de base y reacciones. / Accessi motorizzati: composizioni elementi torre, zavorre di base e reazioni aggiornate. / Acessos motorizados: composições de coluna, lastro da base e reacções adaptadas. / Лифты : адаптированная композиция мачты, базовый балласт и нагрузки.

**2,45 m - ZY 800 -  - C50**

| FAVAK (m)   | 30     | 35   | 40   | 45   | 50   | 55   | 60   | 65   | 70   | 75   | 80   |
|---|--------|------|------|------|------|------|------|------|------|------|------|
|  (m)         | 65,6   | 63,9 | 67,3 | 67,3 | 65,6 | 65,6 | 63,9 | 63,9 | 62,3 | 62,3 | 60,6 |
|  /P+ (m)     | 65,6   | 63,9 | 63,9 | 60,6 | 58,9 | 65,6 | 63,9 | 63,9 | 62,3 | 62,3 | 60,6 |
|              | 2 m    | 1    | 1    | 1    | 1    | 1    | 1    | 1    | 1    | 1    | 1    |
|   | 3,33 m | 1    | 2    | 0    | 0    | 1    | 1    | 2    | 0    | 0    | 1    |
|   | 5 m    | 12   | 11   | 13   | 13   | 12   | 12   | 11   | 11   | 12   | 11   |
| FI (t)  | ● 140  | 134  | 145  | 148  | 143  | 150  | 145  | 145  | 138  | 137  | 138  |
|   | ■ 177  | 163  | 185  | 191  | 178  | 190  | 183  | 185  | 179  | 185  | 178  |
|  (m) D50     | 57,3   | 57,3 | 57,3 | 57,3 | 57,3 | 55,6 | 55,6 | 55,6 | 53,9 | 52,3 | 52,3 |
|  /P+ (m) D50 | 57,3   | 57,3 | 57,3 | 57,3 | 57,3 | 55,6 | 55,6 | 55,6 | 53,9 | 52,3 | 52,3 |

**2,45 m - ZY 854 -  - C50**

| FAVAK (m)   | 30     | 35   | 40   | 45   | 50   | 55   | 60   | 65   | 70   | 75   | 80   |
|---|--------|------|------|------|------|------|------|------|------|------|------|
|  (m)           | 77,5   | 77,5 | 77,5 | 77,5 | 77,5 | 77,5 | 75,9 | 75,9 | 74,2 | 74,2 | 72,5 |
|  /P+ (m)       | 77,5   | 77,5 | 77,5 | 77,5 | 77,5 | 77,5 | 75,9 | 75,9 | 74,2 | 74,2 | 72,5 |
|                | 2 m    | 1    | 1    | 1    | 1    | 1    | 1    | 1    | 1    | 1    | 1    |
|   | 3,33 m | 0    | 0    | 0    | 0    | 0    | 1    | 1    | 2    | 2    | 0    |
|   | 5 m    | 15   | 15   | 15   | 15   | 15   | 15   | 14   | 14   | 13   | 13   |
| FI (t)  | ● 180  | 180  | 186  | 189  | 187  | 191  | 187  | 190  | 183  | 184  | 182  |
|   | ■ 266  | 263  | 267  | 273  | 271  | 282  | 275  | 277  | 275  | 279  | 265  |
|  (m) D50     | 64,2   | 65,9 | 65,9 | 67,5 | 67,5 | 64,2 | 64,2 | 64,2 | 64,2 | 62,5 | 62,5 |
|  /P+ (m) D50 | 64,2   | 65,9 | 65,9 | 67,5 | 67,5 | 64,2 | 64,2 | 64,2 | 64,2 | 62,5 | 62,5 |

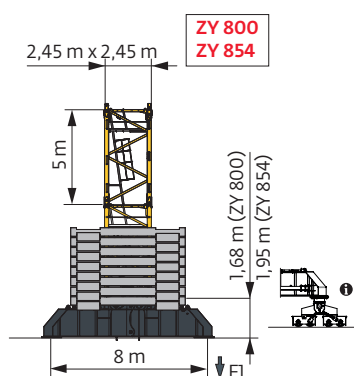

Ancrages / Verankerungen / Anchorages / Anclajes / Ancoraggi  
Ancoragem / нкера



Lest de base / Grundballast / Base ballast / Lastre de base / Zavorra di base  
 Lastro da base / Базовый Балласт

**⚖️ (t) / 📏 2,45 m - ZY 800 - 🏠 - C50**

| ▲▼▲▲ (m) | 30  | 35 | 40  | 45  | 50 | 55  | 60  | 65  | 70 | 75  | 80  |
|----------|-----|----|-----|-----|----|-----|-----|-----|----|-----|-----|
| 67,3     |     |    | 108 | 108 |    |     |     |     |    |     |     |
| 65,6     | 108 |    | 96  | 96  | 96 | 120 |     |     |    |     |     |
| 63,9     | 96  | 84 | 84  | 84  | 84 | 108 | 108 | 108 |    |     |     |
| 62,3     | 84  | 72 | 72  | 72  | 72 | 84  | 84  | 84  | 96 | 108 |     |
| 60,6     | 72  | 72 | 72  | 60  | 60 | 72  | 72  | 72  | 84 | 96  | 108 |
| 55,6     | 60  | 60 | 60  | 48  | 60 | 60  | 72  | 72  | 84 | 84  | 96  |
| 50,6     | 48  | 60 | 48  | 48  | 60 | 60  | 72  | 72  | 84 | 84  | 96  |
| 45,6     | 48  | 48 | 48  | 36  | 60 | 60  | 72  | 60  | 84 | 84  | 96  |
| 40,6     | 36  | 48 | 36  | 36  | 48 | 48  | 72  | 60  | 72 | 72  | 84  |
| 35,6     | 36  | 36 | 36  | 36  | 48 | 48  | 72  | 60  | 72 | 72  | 84  |
| 30,6     | 36  | 36 | 36  | 36  | 48 | 48  | 72  | 60  | 72 | 72  | 84  |
| 25,6     | 36  | 36 | 36  | 36  | 48 | 48  | 72  | 60  | 60 | 72  | 72  |
| 20,6     | 36  | 36 | 36  | 36  | 48 | 48  | 72  | 60  | 60 | 60  | 72  |
| 15,6     | 36  | 36 | 36  | 36  | 48 | 48  | 72  | 60  | 60 | 60  | 72  |

**⚖️ (t) / 📏 2,45 m - ZY 854 - 🏠 - C50**

| ▲▼▲▲ (m) | 30  | 35  | 40  | 45  | 50  | 55  | 60  | 65  | 70  | 75  | 80  |
|----------|-----|-----|-----|-----|-----|-----|-----|-----|-----|-----|-----|
| 77,5     | 204 | 192 | 204 | 204 | 192 | 216 |     |     |     |     |     |
| 75,9     | 192 | 180 | 180 | 180 | 180 | 204 | 204 | 216 |     |     |     |
| 74,2     | 180 | 168 | 168 | 168 | 168 | 192 | 192 | 192 | 204 | 216 |     |
| 72,5     | 168 | 156 | 144 | 144 | 144 | 168 | 168 | 168 | 180 | 192 | 204 |
| 67,5     | 120 | 108 | 108 | 96  | 96  | 120 | 120 | 120 | 132 | 144 | 144 |
| 62,5     | 84  | 72  | 60  | 60  | 60  | 84  | 84  | 84  | 96  | 96  | 96  |
| 57,5     | 60  | 60  | 48  | 48  | 48  | 60  | 60  | 60  | 84  | 84  | 96  |
| 52,5     | 48  | 48  | 48  | 36  | 48  | 48  | 60  | 60  | 84  | 84  | 96  |
| 47,5     | 48  | 48  | 36  | 36  | 48  | 48  | 60  | 60  | 72  | 72  | 84  |
| 42,5     | 36  | 36  | 36  | 36  | 48  | 48  | 60  | 60  | 72  | 72  | 84  |
| 37,5     | 24  | 36  | 24  | 36  | 48  | 48  | 60  | 48  | 72  | 72  | 84  |
| 32,5     | 24  | 36  | 24  | 24  | 48  | 48  | 60  | 48  | 60  | 60  | 72  |
| 27,5     | 24  | 36  | 24  | 24  | 48  | 48  | 60  | 48  | 60  | 60  | 72  |
| 22,5     | 24  | 36  | 24  | 24  | 48  | 48  | 60  | 48  | 60  | 60  | 72  |
| 17,5     | 24  | 36  | 24  | 24  | 48  | 48  | 60  | 48  | 48  | 60  | 60  |

Courbes de charges / Lastkurven / Load curves / Curvas de cargas / Curve di carico / Curvas de carga / Кривые нагрузок



| ▼▲▲▲▲ (m) |           |             | 17   | 20 | 25   | 30   | 35   | 40   | 42   | 45   | 47   | 50   | 52   | 55  | 57  | 60  | 62  | 65  | 67  | 70  | 72  | 75  | 77  | 80  | m    |
|-----------|-----------|-------------|------|----|------|------|------|------|------|------|------|------|------|-----|-----|-----|-----|-----|-----|-----|-----|-----|-----|-----|------|
| ▼▲▲▲      | ▼▲▲▲ 20 t | ▼▲▲▲ 10 t   | ▼▲▲▲ |    |      |      |      |      |      |      |      |      | ▼▲▲▲ |     |     |     |     |     |     |     |     |     |     |     |      |
| 80        | 4 → 20,4  | 35,5 - 39,3 | 20   | 20 | 15,6 | 12,4 | 10,2 | 9,8  | 9,2  | 8,5  | 8,1  | 7,5  | 7,1  | 6,6 | 6,3 | 5,9 | 5,7 | 5,3 | 5,1 | 4,8 | 4,6 | 4,4 | 4,2 | 4   | t    |
|           | 4 → 22    | 38,1 - 42   | 20   | 20 | 17,2 | 13,7 | 11,2 | 10   | 10   | 9,4  | 8,9  | 8,2  | 7,8  | 7,3 | 7   | 6,5 | 6,2 | 5,8 | 5,5 | 5,2 | 5   | 4,7 | 4,5 | 4,2 | t P+ |
| 75        | 4 → 21    | 36,7 - 40,6 | 20   | 20 | 16,2 | 13   | 10,6 | 10   | 9,6  | 8,8  | 8,4  | 7,8  | 7,4  | 6,9 | 6,6 | 6,2 | 5,9 | 5,6 | 5,4 | 5,1 | 4,9 | 4,6 |     | t   |      |
|           | 4 → 22,8  | 39,5 - 44   | 20   | 20 | 17,9 | 14,3 | 11,7 | 10   | 10   | 9,7  | 9,2  | 8,5  | 8,1  | 7,6 | 7,3 | 6,8 | 6,5 | 6,1 | 5,9 | 5,6 | 5,3 | 5,1 | t   | P+  |      |
| 70        | 4 → 23,9  | 41,9 - 46,1 | 20   | 20 | 18,9 | 15,2 | 12,6 | 10,6 | 10   | 10   | 9,8  | 9,1  | 8,7  | 8,1 | 7,8 | 7,3 | 7   | 6,6 | 6,3 | 6   |     | t   |     |     |      |
|           | 4 → 25,8  | 44,8 - 49   | 20   | 20 | 20   | 16,7 | 13,8 | 11,7 | 11   | 10   | 10   | 9,7  | 9,2  | 8,6 | 8,2 | 7,6 | 7,3 | 6,8 | 6,6 | 6,2 | t   | P+  |     |     |      |
| 65        | 4 → 26,1  | 45,9 - 50,6 | 20   | 20 | 20   | 17   | 14,1 | 11,9 | 11,2 | 10,3 | 10   | 10   | 9,7  | 9,1 | 8,7 | 8,2 | 7,8 | 7,4 |     | t   |     |     |     |     |      |
|           | 4 → 28,2  | 47,4 - 52   | 20   | 20 | 20   | 18,5 | 15,1 | 12,7 | 11,8 | 10,8 | 10,1 | 10   | 10   | 9,3 | 8,8 | 8,3 | 7,9 | 7,4 | t   | P+  |     |     |     |     |      |
| 60        | 4 → 27,5  | 48,4 - 53,4 | 20   | 20 | 20   | 18,1 | 15   | 12,8 | 12   | 11   | 10,4 | 10   | 10   | 9,6 | 9,2 | 8,7 |     | t   |     |     |     |     |     |     |      |
|           | 4 → 28,9  | 49,8 - 54,6 | 20   | 20 | 20   | 19,1 | 15,8 | 13,3 | 12,5 | 11,4 | 10,8 | 10   | 10   | 9,9 | 9,5 | 8,9 | t   | P+  |     |     |     |     |     |     |      |
| 55        | 4 → 28,4  | 49,9 - 55   | 20   | 20 | 20   | 18,7 | 15,6 | 13,2 | 12,5 | 11,4 | 10,8 | 10   | 10   | 10  |     | t   |     |     |     |     |     |     |     |     |      |
|           | 4 → 29,6  | 50,2 - 55   | 20   | 20 | 20   | 19,7 | 16,2 | 13,6 | 12,8 | 11,6 | 11   | 10,1 | 10   | 10  | t   | P+  |     |     |     |     |     |     |     |     |      |
| 50        | 4 → 30,3  |             | 20   | 20 | 20   | 20   | 16,9 | 14,4 | 13,5 | 12,4 | 11,8 | 10,9 |      | t   |     |     |     |     |     |     |     |     |     |     |      |
|           | 4 → 31,1  |             | 20   | 20 | 20   | 20   | 17,5 | 15   | 14,2 | 13,1 | 12,5 | 11,6 | t    | P+  |     |     |     |     |     |     |     |     |     |     |      |
| 45        | 4 → 30,5  |             | 20   | 20 | 20   | 20   | 17   | 14,5 | 13,6 | 12,5 |      | t    |      |     |     |     |     |     |     |     |     |     |     |     |      |
|           | 4 → 30,5  |             | 20   | 20 | 20   | 20   | 17,2 | 14,7 | 13,9 | 12,9 | t    | P+   |      |     |     |     |     |     |     |     |     |     |     |     |      |
| 40        | 4 → 30,5  |             | 20   | 20 | 20   | 20   | 17   | 14,5 |      | t    |      |      |      |     |     |     |     |     |     |     |     |     |     |     |      |
|           | 4 → 31    |             | 20   | 20 | 20   | 20   | 17,5 | 15   | t    | P+   |      |      |      |     |     |     |     |     |     |     |     |     |     |     |      |
| 35        | 4 → 30,9  |             | 20   | 20 | 20   | 20   | 17,3 |      | t    |      |      |      |      |     |     |     |     |     |     |     |     |     |     |     |      |
|           | 4 → 30,9  |             | 20   | 20 | 20   | 20   | 17,3 | t    | P+   |      |      |      |      |     |     |     |     |     |     |     |     |     |     |     |      |
| 30        | 4 → 30    |             | 20   | 20 | 20   | 20   |      | t    |      |      |      |      |      |     |     |     |     |     |     |     |     |     |     |     |      |
|           | 4 → 30    |             | 20   | 20 | 20   | 20   | t    | P+   |      |      |      |      |      |     |     |     |     |     |     |     |     |     |     |     |      |

▼▲▲▲ = ▼▲▲▲ - 1,43 t max.



| ▼▲▲▲▲ (m) |            |             | 17   | 20 | 25   | 30   | 35   | 40   | 42   | 45   | 47   | 50   | 52   | 55  | 57  | 60  | 62  | 65  | 67  | 70  | 72  | 75  | 77  | 80  | m    |
|-----------|------------|-------------|------|----|------|------|------|------|------|------|------|------|------|-----|-----|-----|-----|-----|-----|-----|-----|-----|-----|-----|------|
| ▼▲▲▲      | ▼▲▲▲ 20 t  | ▼▲▲▲ 10 t   | ▼▲▲▲ |    |      |      |      |      |      |      |      |      | ▼▲▲▲ |     |     |     |     |     |     |     |     |     |     |     |      |
| 80        | 3,3 → 20,9 | 36,8 - 37,7 | 20   | 20 | 16,1 | 12,9 | 10,7 | 9,3  | 8,7  | 8    | 7,5  | 6,9  | 6,6  | 6,1 | 5,8 | 5,4 | 5,1 | 4,8 | 4,6 | 4,3 | 4,1 | 3,8 | 3,7 | 3,5 | t    |
|           | 3,3 → 22,5 | 39,4 - 40,1 | 20   | 20 | 17,7 | 14,1 | 11,7 | 10   | 9,4  | 8,8  | 8,3  | 7,7  | 7,3  | 6,7 | 6,4 | 5,9 | 5,6 | 5,2 | 5   | 4,6 | 4,4 | 4,1 | 3,9 | 3,7 | t P+ |
| 75        | 3,3 → 21,5 | 38,1 - 39   | 20   | 20 | 16,8 | 13,5 | 11,1 | 9,7  | 9,1  | 8,3  | 7,9  | 7,3  | 6,9  | 6,4 | 6,1 | 5,7 | 5,4 | 5,1 | 4,9 | 4,6 | 4,4 | 4,1 |     | t   |      |
|           | 3,3 → 23,2 | 40,8 - 42,1 | 20   | 20 | 18,3 | 14,7 | 12,2 | 10,3 | 10   | 9,2  | 8,7  | 8    | 7,6  | 7,1 | 6,7 | 6,3 | 6   | 5,6 | 5,4 | 5   | 4,8 | 4,6 | t   | P+  |      |
| 70        | 3,3 → 24,3 | 43,4 - 44,4 | 20   | 20 | 19,3 | 15,6 | 13   | 11,1 | 10,4 | 9,8  | 9,3  | 8,6  | 8,2  | 7,6 | 7,3 | 6,8 | 6,5 | 6,1 | 5,9 | 5,6 |     | t   |     |     |      |
|           | 3,3 → 26,4 | 46,4 - 47,3 | 20   | 20 | 20   | 17,2 | 14,3 | 12,2 | 11,5 | 10,4 | 10   | 9,3  | 8,8  | 8,2 | 7,8 | 7,2 | 6,9 | 6,4 | 6,2 | 5,8 | t   | P+  |     |     |      |
| 65        | 3,3 → 26,7 | 47,8 - 49   | 20   | 20 | 20   | 17,5 | 14,6 | 12,4 | 11,7 | 10,8 | 10,2 | 9,7  | 9,3  | 8,7 | 8,3 | 7,8 | 7,4 | 7   |     | t   |     |     |     |     |      |
|           | 3,3 → 28,9 | 49,4 - 50,3 | 20   | 20 | 20   | 19,1 | 15,7 | 13,2 | 12,4 | 11,3 | 10,7 | 10   | 9,6  | 8,9 | 8,5 | 7,9 | 7,6 | 7,1 | t   | P+  |     |     |     |     |      |
| 60        | 3,3 → 28,4 | 50,9 - 52,1 | 20   | 20 | 20   | 18,8 | 15,7 | 13,4 | 12,6 | 11,6 | 11   | 10,2 | 10   | 9,4 | 9   | 8,4 |     | t   |     |     |     |     |     |     |      |
|           | 3,3 → 29,6 | 51,9 - 53   | 20   | 20 | 20   | 19,7 | 16,4 | 13,9 | 13,1 | 12   | 11,4 | 10,5 | 10   | 9,6 | 9,1 | 8,6 | t   | P+  |     |     |     |     |     |     |      |
| 55        | 3,3 → 29,2 | 52,5 - 53,7 | 20   | 20 | 20   | 19,4 | 16,2 | 13,9 | 13,1 | 12,1 | 11,4 | 10,6 | 10,1 | 9,7 |     | t   |     |     |     |     |     |     |     |     |      |
|           | 3,3 → 30,3 | 52,3 - 55   | 20   | 20 | 20   | 20   | 16,7 | 14,2 | 13,3 | 12,2 | 11,5 | 10,6 | 10,1 | 10  | t   | P+  |     |     |     |     |     |     |     |     |      |
| 50        | 3,3 → 31,6 |             | 20   | 20 | 20   | 20   | 17,8 | 15,3 | 14,4 | 13,3 | 12,6 | 11,7 |      | t   |     |     |     |     |     |     |     |     |     |     |      |
|           | 3,3 → 31,8 |             | 20   | 20 | 20   | 20   | 18,1 | 15,6 | 14,8 | 13,7 | 13   | 12,1 | t    | P+  |     |     |     |     |     |     |     |     |     |     |      |
| 45        | 3,3 → 31,2 |             | 20   | 20 | 20   | 20   | 17,5 | 15   | 14,2 | 13   |      | t    |      |     |     |     |     |     |     |     |     |     |     |     |      |
|           | 3,3 → 31,3 |             | 20   | 20 | 20   | 20   | 17,7 | 15,3 | 14,5 | 13,4 | t    | P+   |      |     |     |     |     |     |     |     |     |     |     |     |      |
| 40        | 3,3 → 31,3 |             | 20   | 20 | 20   | 20   | 17,6 | 15   |      | t    |      |      |      |     |     |     |     |     |     |     |     |     |     |     |      |
|           | 3,3 → 31,8 |             | 20   | 20 | 20   | 20   | 18   | 15,6 | t    | P+   |      |      |      |     |     |     |     |     |     |     |     |     |     |     |      |
| 35        | 3,3 → 31,6 |             | 20   | 20 | 20   | 20   | 17,8 |      | t    |      |      |      |      |     |     |     |     |     |     |     |     |     |     |     |      |
|           | 3,3 → 31,6 |             | 20   | 20 | 20   | 20   | 17,8 | t    | P+   |      |      |      |      |     |     |     |     |     |     |     |     |     |     |     |      |
| 30        | 3,3 → 30   |             | 20   | 20 | 20   | 20   |      | t    |      |      |      |      |      |     |     |     |     |     |     |     |     |     |     |     |      |
|           | 3,3 → 30   |             | 20   | 20 | 20   | 20   | t    | P+   |      |      |      |      |      |     |     |     |     |     |     |     |     |     |     |     |      |



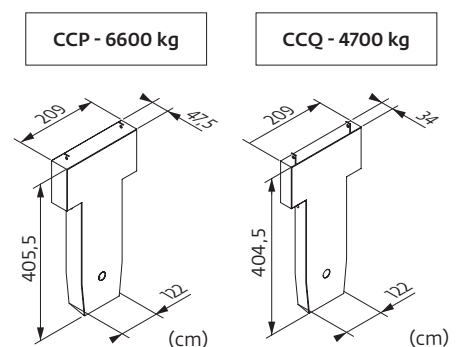

▼▲▲▲ = ▼▲▲▲ - 0,64 t max.

Lest de contre-flèche / Gegenauslegerballast / Counter-jib ballast / Lastre de contra-flecha / Zavorra di controbraccio / Lastro da contra lança / Противовес стрелы













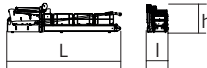
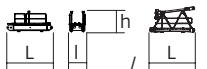
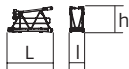

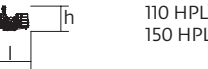
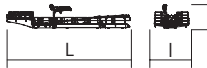
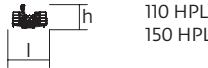
| ▼▲▲▲ | 110 HPL™ |         |        | 150 HPL™ GH |         |        |
|------|----------|---------|--------|-------------|---------|--------|
|      | 6600 kg  | 4700 kg | ≡ (kg) | 6600 kg     | 4700 kg | ≡ (kg) |
| 80 m | 5        | 2       | 42400  | 6           | 0       | 39600  |
| 75 m | 4        | 3       | 40500  | 5           | 1       | 37700  |
| 70 m | 4        | 3       | 40500  | 5           | 1       | 37700  |
| 65 m | 4        | 3       | 40500  | 5           | 1       | 37700  |
| 60 m | 6        | 0       | 39600  | 4           | 2       | 35800  |
| 55 m | 5        | 1       | 37700  | 3           | 3       | 33900  |
| 50 m | 6        | 2       | 49000  | 7           | 0       | 46200  |
| 45 m | 7        | 0       | 46200  | 5           | 2       | 42400  |
| 40 m | 5        | 2       | 42400  | 6           | 0       | 39600  |
| 35 m | 5        | 1       | 37700  | 4           | 2       | 35800  |
| 30 m | 3        | 3       | 33900  | 4           | 1       | 31100  |

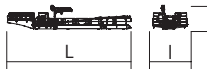
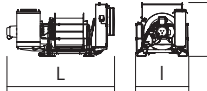
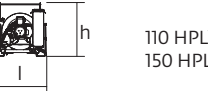
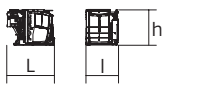
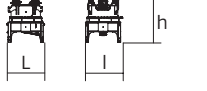





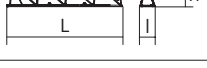



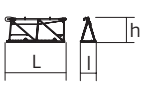
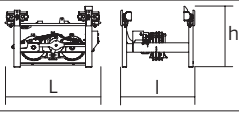

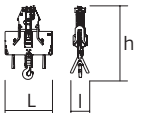

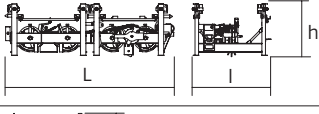

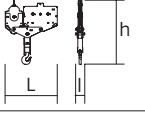

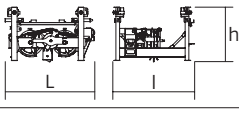

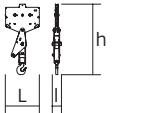
Encombrenment et poids / Abmessungen und Gewicht / Dimensions and weight / Dimensiones y peso / Ingombro e peso  
 dimensões e pesos / габаритные размеры и вес

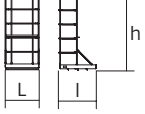
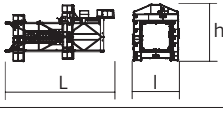
Partie tournante / Drehender Kranteil / Slewing crane part / Parte giratoria  
 Parte rotante / Parte rotativa / Поворотная часть :  80 m -  -  -  110 HPL™

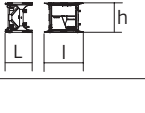

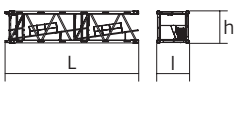
| Partie tournante / Drehender Kranteil / Slewing crane part<br>Parte giratoria / Parte rotante / Parte rotativa / Поворотная часть | L (m)   | l (m)  | h (m)  | kg<br>(+/- 5%) |                |              |
|---|---|--|--|----------------|----------------|--------------|
|    | 12  | 2,2  | 2,5  | 13465          |                |              |
|    | 12  | 2,2  | 2,5  | 17885          |                |              |
|    | 11,92   | 2,2  | 2,81   | 13415          |                |              |
| Contre-flèche / Gegenausleger<br>Counter-jib / Contra-flecha<br>Controbraccio / Contra-lança<br>Контр-стрела                      |  /    | 4,56<br>4,34   | 1,62<br>1,38   | 4350<br>3170   |                |              |
|   |  110 HPL™<br> 150 HPL™ GH                    | 16,25<br>16,25   | 5,66<br>6,69   | 3,93<br>3,93   | 14925<br>15630 |              |
|   |  110 HPL™<br> 150 HPL™ GH                | 20,26<br>20,26   | 5,66<br>6,69   | 3,93<br>3,93   | 19140<br>19660 |              |
|   |  110 HPL™  | 16,25  | 5,66   | 3,93           | 20785          |              |
|   |  110 HPL™  | 20,26  | 5,66   | 3,93           | 25000          |              |
|   | Treuril de levage (+ câble) / Hubwerk (+ Seil)<br>Hoisting winch (+ rope) / Mecanismo de elevación (+ cabo)<br>Argano di sollevamento (+ fune)<br>Guincho de elevação (+ cabo)<br>Подъемная лебедка (+ канатом) |  110 HPL™<br> 150 HPL™ GH | 3,78<br>4,82   | 1,85<br>1,93   | 1,88<br>1,97   | 5860<br>8745 |
|   |   | Cabine / Kabine<br>Cab / Cabina<br>Cabina / Cabina<br>Кабина   |  Ultra View | 3,36           | 2,28           | 2,49         |
|   | Pivot / Krankopf<br>Towerhead / Pivote<br>Portaralla / Pivot<br>Секция поворотной части   |  |  2,45 m     | 2,68           | 2,49           | 3,03         |
|    |   |  | 6,68   | 2,49           | 3,03           | 15640        |
| Elément de flèche / Auslegerement<br>Jib section / Elemento de flecha<br>Elemento di braccio / Elemento de lança<br>Секция стрелы |  ①   | 7,7  | 1,55   | 2,48           | 8665           |              |
|   |  ②   | 10,35  | 2,27   | 2,47           | 8220           |              |
|   |  ③   | 6,37   | 1,38   | 2,43           | 3245           |              |
|   |  ④   | 10,38  | 1,38   | 2,37           | 4295           |              |
|   |  ⑤   | 10,4   | 1,38   | 2,22           | 3225           |              |
|   |  ⑦<br> ⑩                                  | 10,25<br>10,08   | 1,38<br>1,38   | 2,2<br>1,55    | 2265<br>830    |              |

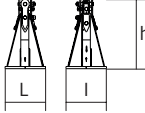
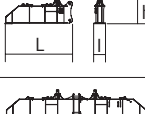
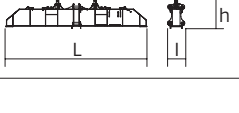
|  |   |  | L (m)  | l (m)  | h (m)  | kg<br>(+/- 5%)   |
|--|---|--|--|--|--|--|
| Élément de flèche / Auslegerelement<br>Jib section / Elemento de flecha<br>Elemento di braccio / Elemento de lança<br>Секция стрелы  |    | ⑥<br>⑧<br>⑨<br>⑩   | 5,36   | 1,38   | 2,22   | 1365   |
|  |   |  | 5,3  | 1,38   | 2,13   | 780  |
|  |   |  | 5,21   | 1,38   | 1,87   | 665  |
|  |   |  | 5,18   | 1,38   | 1,57   | 565  |
|  |   |  | 1,67   | 1,57   | 0,58   | 260  |
| Chariot / Laufkatze<br>Trolley / Carrello<br>Carro / Carro-distribuidor<br>Тележка   |    | <br>20 t     | 2,23   | 1,73   | 1,42   | 760  |
| Moufle / Hubflasche<br>Pulley block / Aparejo<br>Bozzello / Cadernal<br>Полиспаст  |    | <br>20 t     | 1,56   | 0,58   | 2,44   | 850  |
| Chariot / Laufkatze<br>Trolley / Carrello<br>Carro / Carro-distribuidor<br>Тележка   |    | <br>20 t     | 3,8  | 1,7  | 1,25   | 1120   |
| Moufle / Hubflasche<br>Pulley block / Aparejo<br>Bozzello / Cadernal<br>Полиспаст  |    | <br>20 t     | 1,91   | 0,34   | 2,34   | 920  |
| Chariot / Laufkatze<br>Trolley / Carrello<br>Carro / Carro-distribuidor<br>Тележка   |   | <br>10 t     | 2  | 1,7  | 1,25   | 600  |
| Moufle / Hubflasche<br>Pulley block / Aparejo<br>Bozzello / Cadernal<br>Полиспаст  |  | <br>10 t   | 1,25   | 0,34   | 2,58   | 610  |
| Nacelle de chariot/ Arbeitsbühne an der Laufkatze<br>Trolley inspection platform / Gondola de carro<br>Navicella-carrelino/ Cesta do carro<br>Платформа тележки              |  |  | 0,96   | 1,05   | 2,12   | 55   |
| <b>Pyłone / Kranturm / Crane tower</b>   |   |  |  |  |  |  |
| <b>Mástil / Torre / Torre Башня крана</b>  |   |  |  |  |  |  |
| T 851  |  | <br>2,45 m | 11,18  | 4,84   | 5,8  | 15750  |
| K 84/K 84-2  |  | <br>2,45 m | 2,24   | 3,24   | 2,5  | 3050   |
| KRM 849B<br>K 85/KR 84B2<br>KM 850.10B<br>KM 850.14B<br>K 85/KR 84A2<br>KMT 850.10A<br>KMT 850.14A<br>K 849A<br>KMT 849A<br>KR 849A<br>KRMT 849A<br>KRMT 849C<br>KMT 850.10C |  | <br>2,45 m | 10,24<br>10,24<br>10,32<br>10,32<br>5,24<br>5,32<br>5,32<br>5,23<br>5,23<br>5,23<br>5,23<br>5,23<br>5,23<br>5,23<br>3,57<br>3,65 | 2,55<br>2,54<br>2,54<br>2,54<br>2,54<br>2,54<br>2,54<br>2,53<br>2,53<br>2,55<br>2,53<br>2,5<br>2,5<br>2,55<br>2,55<br>2,54 | 2,53<br>2,5<br>2,51<br>2,51<br>2,5<br>2,51<br>2,51<br>2,5<br>2,53<br>2,5<br>2,53<br>2,5<br>2,5<br>2,53<br>2,53<br>2,51 | 7800<br>9635<br>10070<br>11190<br>5550<br>5450<br>5990<br>3400<br>3150<br>4290<br>4090<br>3205<br>4230 |
| Pieds de scellement / Verankerungsfüße<br>Fixing angles / Pie de empotramiento<br>Montante da annegare / Angulos fixadores<br>анкера   |  | P 63A / P 800B<br>P 854A   | 0,75<br>0,9  | 0,75<br>0,9  | 1,28<br>1,5  | 465<br>940   |
| 1/2 Bras de croix / 1/2 Fundamentkreuzträger<br>1/2 Cross girder / 1/2 Brazo en cruz<br>1/2 Braccio croce / 1/2 Braço da cruz<br>1/2 Поперечная балка                        |  | ZY 800<br>ZY 854   | 5,68<br>5,7  | 0,98<br>0,98   | 1,92<br>2,27   | 4720<br>6430   |
| Bras de croix / Fundamentkreuzträger<br>Cross girder / Brazo en cruz<br>Braccio croce / Braço da cruz<br>Поперечная балка  |  | ZY 800<br>ZY 854   | 11,96<br>11,9  | 1,39<br>1,42   | 1,92<br>2,27   | 10075<br>14000   |

Mécanismes / Triebwerke / Mechanisms / Mecanismos / Meccanismi  
 Mecanismos / Механизмы

| 400 V - 50 Hz |                             |                        |  |             |           |            |              |          |            |            |         |           | ch - PS<br>hp | kW  |        |
|---------------|-----------------------------|------------------------|--|-------------|-----------|------------|--------------|----------|------------|------------|---------|-----------|---------------|-----|--------|
|               | <b>110 HPL™ 50</b>          | m/min<br>t             | 42<br>10                                       | 54,5<br>7,5 | 76<br>5   | 115<br>2,5 | 172,5<br>0,2 | 21<br>20 | 27,5<br>15 | 39<br>10   | 59<br>5 | 93<br>0,3 | 110           | 82  | 1069 m |
|               | <b>150 HPL™ 50<br/>GH</b>   | m/min<br>t             | 55<br>10                                       | 68,5<br>7,5 | 92,5<br>5 | 144<br>2,5 | 195<br>0,8   | 28<br>20 | 35<br>15   | 48,5<br>10 | 80<br>5 | 97,5<br>3 | 150           | 110 | 1200 m |
|               | <b>10 DVF 10<br/>Optima</b> | m/min                  | 0 → 80 (20 t) 0 → 100 (12,5 t) 0 → 110 (6,3 t) |             |           |            |              |          |            |            |         | 10        | 7,4           |     |        |
|               | <b>RVF 174<br/>Optima+</b>  | tr/min<br>U/min<br>rpm | 0 → 0,7  |             |           |            |              |          |            |            |         | 4 x 10    | 4 x 7,5       |     |        |
|               |                             |                        |  |             |           |            |              |          |            |            |         |           |               |     |        |

|                         |  |            |
|-------------------------|--|------------|
|                         | <b>IEC 60204-32</b>                                    | <b>kVA</b> |
| 400 V (+10% -10%) 50 Hz | 110 HPL™ : 134 → 90 kVA<br>150 HPL™ GH : 166 → 106 kVA |            |

|  | <b>FR</b>  | <b>DE</b>  | <b>EN</b>   | <b>ES</b>   | <b>IT</b>   | <b>PT</b>   | <b>RU</b>   |
|--|--|--|---|---|---|---|---|
|  | Profil de vent suivant EN 14439 C50-D50  | Windbedingungen gemäss EN 14439 C50-D50  | Wind conditions according to EN 14439 C50-D50   | Conformidad de los condiciones de viento EN 14439 C50-D50   | Condizioni del vento secondo EN 14439 C50-D50   | Perfil de vento conforme EN 14439 C50-D50   | Ветровой режим в соответствии с EN 14439 C50-D50  |
|  | Appel de flèche  | Auslegerüberhöhung   | Jib elevation   | Elevación de la flecha  | Inclinazione braccio  | Desvio da lança   | подъем стрелы   |
|  | Équipements standards  | Standardausrüstungen   | Standard equipment  | Equipamiento de serie   | Equipaggiamento standard  | Equipamento de série  | Стандартное оборудование  |
|  | Équipements optionnels   | Sonderausrüstungen   | Options   | Equipamiento opcional   | Equipaggiamento in opzione  | Equipamento opcional  | Дополнительное оборудование (опция)   |
|  | Fonction Potain Plus : Courbes de charges Plus   | Funktion Potain Plus: Plus-Lastkurven  | Potain Plus function: Plus load curves  | Función Potain Plus: Diagrama de cargas Plus  | Funzione Potain Plus: Curve di carico Plus  | Função Potain Plus: Diagrama de cargas Plus   | Функция контроля мощности Potain Plus: Диаграммы грузоподъемности Plus  |
|  | Hauteurs sous crochet associées aux courbes de charges Plus  | Hakenhöhen mit Plus-Lastkurven   | Hook heights with Plus load curves  | Altura bajo gancho, usando el diagrama de cargas Plus   | Altezze sotto ganccio con curve di carico Plus  | Altura livre, utilizando o diagrama de cargas Plus  | Высота под крюком для диаграмм грузоподъемности Plus  |
|  | Réactions en service   | Reaktionskräfte in Betrieb   | Reactions in service  | Reacciones en servicio  | Reazioni in servizio  | Reacções em serviço   | Реакция при работе  |
|  | Réactions hors service   | Reaktionskräfte außer Betrieb  | Reactions out of service  | Reacciones fuera de servicio  | Reazioni fuori servizio   | Reacções fora de serviço  | Реакция в покое   |
|  | Poids total du lest<br>Camion 13,4 m   | Ballast-Gesamtgewicht<br>Lkw 13,4 m  | Total ballast weight<br>Lorry 13,4 m  | Peso total del lastre<br>Camión 13,4 m  | Peso totale della zavorra<br>Camion 13,4 m  | Peso total do lastro<br>Camião 13,4 m   | Общий вес балласта<br>Рзуровой автомобиль 13,4 м  |
|  | Conteneur High Cube 40', et/ou Flat Rack 20'   | Container High Cube 40', und/oder Flat Rack 20'  | Container High Cube 40', and/or Flat Rack 20'   | Contenedor High Cube 40', y/o Flat Rack 20'   | Container High Cube 40', e/o Flat Rack 20'  | Contentor High Cube 40', e/ou Flat Rack 20'   | 40-футовый контейнер повышенной вместимости High Cube, и/или 20-футовая открытая платформа Flat Rack                                  |
|  | Levage   | Heben  | Hoisting  | Elevación   | Sollevamento  | Elevação  | Подъем  |
|  | Distribution   | Katzfahren   | Trolleying  | Distribución  | Ditribuzione  | Distribuição  | Перемещение по стреле   |
|  | Orientation  | Schwenken  | Slewing   | Orientación   | Rotazione   | Rotação   | Поворот   |
|  | Translation  | Kranfahren   | Travelling  | Traslación  | Traslazione   | Translação  | Перемещение крана   |
|  | Puissance requise  | Erforderliche Leistung   | Required power  | Potencia Necesaria  | Potenza richiesta   | Potência Necessária   | Потребляемая мощность   |
|  | Fonction Power Control : vitesses treuils adaptées à la puissance disponible                                 | Funktion Power Control: Geschwindigkeiten der Triebwerke werden an die verfügbare Leistung angepasst   | Power Control Function: winch speeds adapted to the available power   | Función Power Control: marchas de los cabrestantes adaptadas a la potencia disponible                   | Funzione Power Control: velocità degli argani adattate alla potenza disponibile                                   | Função Power Control: velocidades de guincho adaptadas à potência disponível  | Функция контроля мощности Power Control: регулировка скорости лебедок в зависимости от доступной мощности                             |
|  | Nous consulter   | Auf Anfrage  | Consult us  | Consultarnos  | Consultateci  | Consultar-nos   | Проконсультируйтесь у нас   |
|  | Document commercial non contractuel. Pour toute information technique se référer à la notice correspondante. | Unverbindliches Vertriebsdokument. Für technische Informationen, siehe die entsprechenden Anweisungen. | This commercial document is not legally binding. For any technical information, please refer to the corresponding instructions. | Documento comercial no contractual. Para cualquier información técnica, ver la noticia correspondiente. | Documento commerciale non vincolante, per tutte le informazioni tecniche fare riferimento al catalogo istruzioni. | Documento comercial não contractual. Para qualquer informação técnica complementar consultar as respectivas instruções. | Этот коммерческий документ не является юридически обязательным. Для получения технической информации, см. соответствующие инструкции. |

