

Igo T 70 A

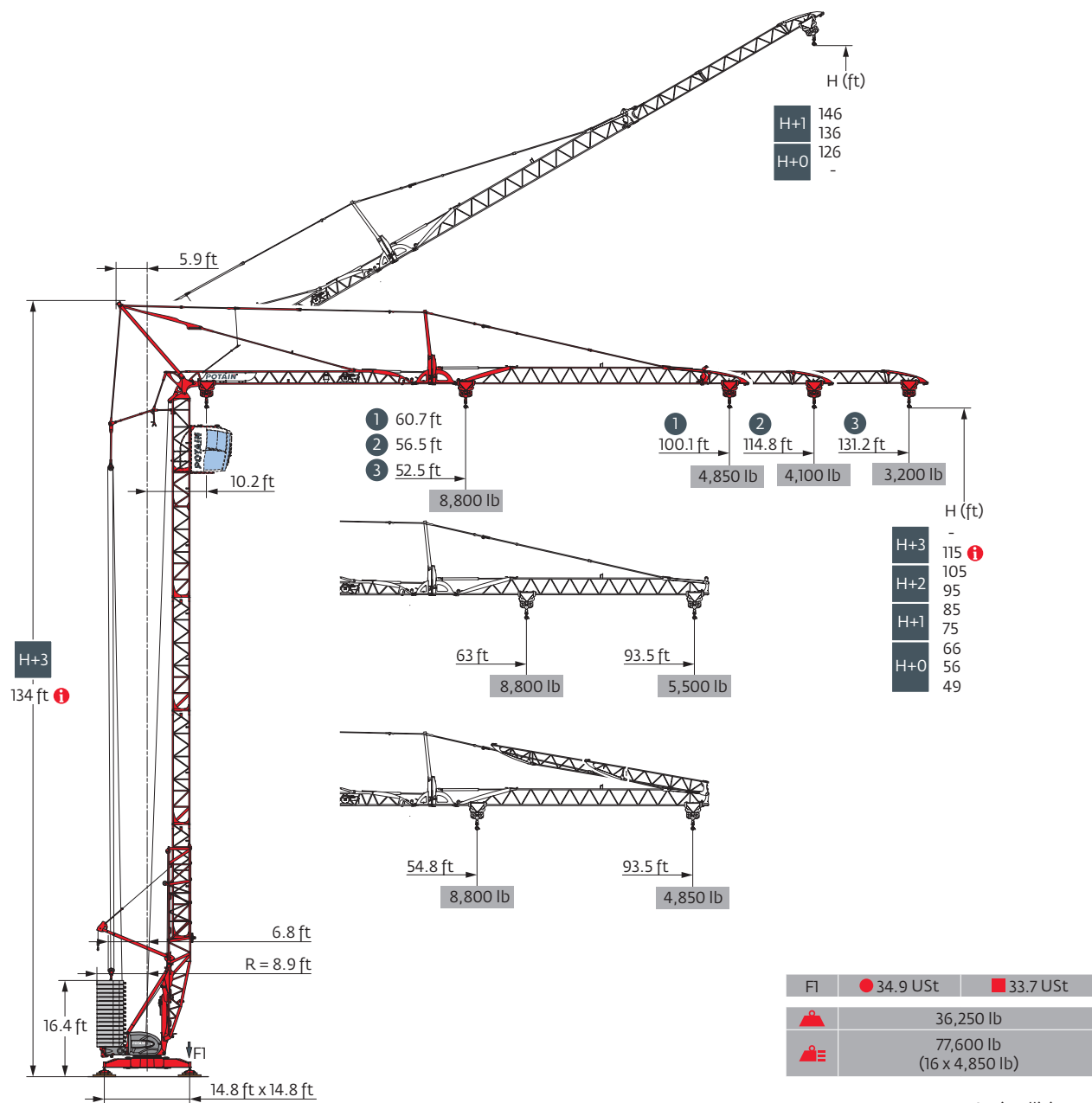

SmartCom

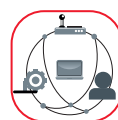

Top Zone

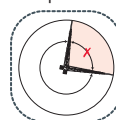

Anti-collision system

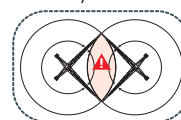

Load curves

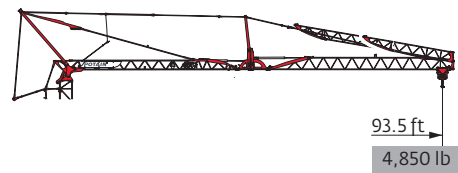
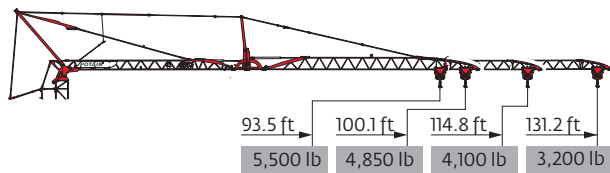

131 ft	10.2	▶	52.5	59.1	65.6	72.2	78.7	85.3	85.8	91.9	98.4	105	111.5	118.1	124.7	131.2	ft	
▲▲▲			8,800	7,650	6,700	6,000	5,400	4,900	-	4,450	4,100	3,800	3,500	3,250	3,050	2,850	lb	
										4,850	4,450	4,100	3,800	3,500	3,250	3,050	2,850	lb
											4,850	4,450	4,150	3,850	3,600	3,400	3,200	lb

115 ft	10.2	▶	56.5	59.1	65.6	72.2	78.7	85.3	91.9	92.9	98.4	98.9	105	111.5	114.8	ft	
▲▲▲			8,800	8,350	7,350	6,550	5,900	5,400	4,900	-	4,500	-	4,200	3,900	3,750	lb	
											4,850	4,500	-	4,200	3,900	3,750	lb
												4,850	4,500	4,200	4,100	lb	

100 ft	10.2	▶	60.7	65.6	72.2	78.7	85.3	91.9	98.4	100.1	ft
▲▲▲			8,800	8,050	7,150	6,450	5,850	5,350	4,950	4,850	lb
										4,850	lb
										4,850	lb

94 ft	10.2	▶	63	65.6	72.2	78.7	85.3	91.9	93.5	ft
▲▲▲			8,800	8,400	7,500	6,750	6,150	5,650	5,500	lb
									4,850	lb
									4,850	lb

131 ft	10.2	▶	54.8	59.1	65.6	72.2	78.7	85.3	90	91.9	93.5	ft	
▲▲▲			8,800	8,050	7,100	6,350	5,700	5,150	-	4,750	4,650	lb	
										4,850	4,750	4,650	lb
											4,850	lb	

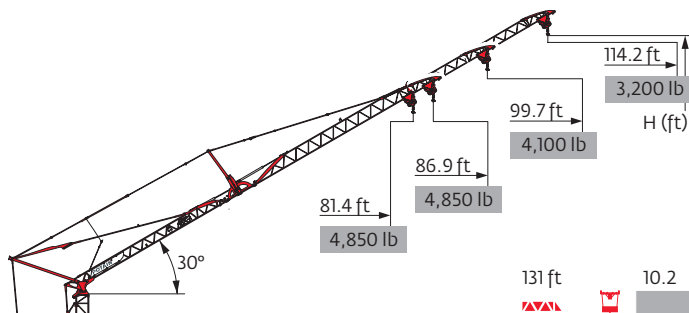

▲▲▲	131 ft	115 ft	100 ft	94 ft
H+1	146	138	-	-
H+0	136	128	120	117

131 ft	10.2	▶	75.5	78.7	80.1	85.3	91.9	98.4	105	114.2	ft	
▲▲▲			4,850	4,550	-	4,150	3,750	3,450	3,200	2,850	lb	
						4,850	4,500	4,150	3,800	3,550	3,200	lb

115 ft	10.2	▶	80.9	85.3	86	91.9	99.7	ft	
▲▲▲			4,850	4,550	-	4,150	3,750	lb	
						4,850	4,500	4,100	lb

100 ft	10.2	▶	86.9	ft
▲▲▲			4,850	lb
			4,850	lb





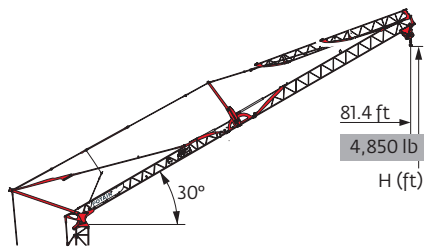

94 ft	10.2	▶	81.4	ft
▲▲▲			4,850	lb
			4,850	lb



▲▲▲	131 ft
	115 ft
H+1	-
H+0	107



131 ft	10.2	▶	81.4	ft
▲▲▲			4,850	lb
			4,850	lb

Mechanisms

480 V - 60 Hz												hp	kW	
	15 LVF 11 Optima	fpm	11	59	98	118	223	6	30	49	59	112	15	11
		lb	4,850	4,850	4,850	3,300	1,210	8,800	8,800	8,800	6,600	2,420		
	3 DVF 5	fpm	49 - 98 - 135 (2,850 → 8,800 lb) 49 - 98 - 148 (0 → 2,850 lb)									3	2.2	
	RVF 151 Optima+	rpm	0 → 0.8									5.5	4	
														

 IEC 60204-32	kVA
480 V (+6% -10%) 60 Hz	 → 17 kVA  → 19 kVA

15 LVF 11 Optima

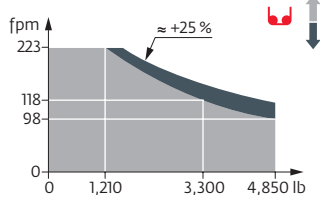

Erection

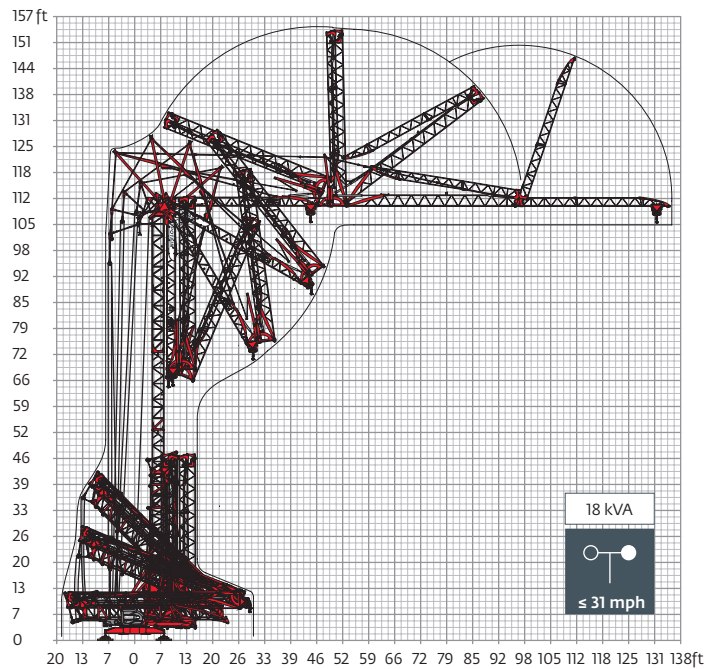
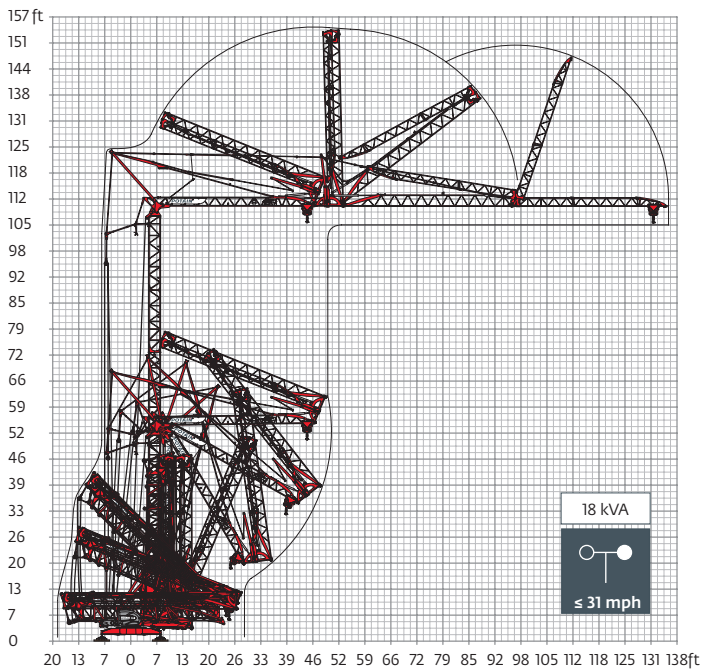

Transport

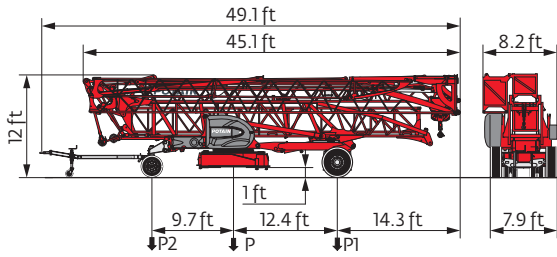

	mph	P (lb)	P1 (lb)	P2 (lb)
DJ100/S120	6	37,410	21,030	16,380
DJ105A/S125A	15.5	38,050	21,500	16,550
..... /..... ⓘ				

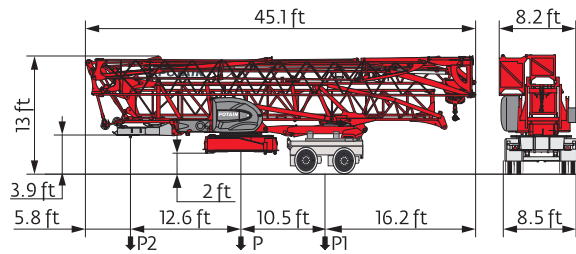

	P (lb)	P1 (lb)	P2 (lb)
North America Highway Axle	39,440	27,230	12,210

The reactions meet the EN 14439 and ASCE 7-10 specifications for "out of service" wind conditions, provided the illustrated wind speed matches required design wind speed for the location of the tower crane. The "out of service" design wind speed was determined in accordance with ASCE 7-10, Figure 26.5-1A. The wind velocity, used for this configuration was 98 mph (158 kph), which represents a nominal design 3-second wind gust at 33 ft (10 m) above ground for Exposure B category. A factor of 0.85 was applied to the 700-year ultimate design wind speed of 115 mph (185 kph), per ASCE 37-02, with the assumption that this crane is considered a temporary structure used during a construction period of 2 years or less.

- R** Rear slewing radius
- ⓘ** Consult us
- ⚙️** Total ballast weight
- ⚙️** Standard equipment
- ⚙️** Slewing
- Reactions in service
- ⚙️** Options
- ⚙️** Travelling
- Reactions out of service
- ⚙️** Hoisting
- ⚙️** Required power
- ⚙️** Weight without load, without ballast, without transport axles, with max. jib and standard height
- ⚙️** Trolleying

⚠️ Hook heights given with plated pulley block
 ⓘ This commercial document is not legally binding
 For any technical information, please refer to the corresponding instructions

