

Manitowoc MLC300

Operator Manual VPC-MAX™ Attachment





WARNING

California Proposition 65

Breathing diesel engine exhaust exposes you to chemicals known to the State of California to cause cancer and birth defects or other reproductive harm.

Always start and operate the engine in a well-ventilated area.

If in an enclosed area, vent the exhaust to the outside.

Do not modify or tamper with the exhaust system.

Do not idle the engine except as necessary.

For more information, go to www.P65warnings.ca.gov/diesel

Batteries, battery posts, terminals, and related accessories can expose you to chemicals, including lead and lead compounds, which are known to the State of California to cause cancer and birth defects or other reproductive harm. Wash hands after handling. For more information, go to www.P65warnings.ca.gov



California Spark Arrestor

Operation of this equipment may create sparks that can start fires around dry vegetation. A spark arrestor may be required. The owner/ operator should contact local fire agencies for laws or regulations relating to fire prevention requirements.





OPERATOR MANUAL

This manual has been prepared for and is considered part of -

MLC300 VPC-MAX™

VPC-MAX Model Number

XXXXXRef

VPC-MAX Serial Number

This manual is divided into the following sections:

SECTION 1	INTRODUCTION
SECTION 2	SAFETY INFORMATION
SECTION 3	OPERATING CONTROLS AND PROCEDURES
SECTION 4	SET-UP AND INSTALLATION
SECTION 5	LUBRICATION
SECTION 6	MAINTENANCE

NOTICE

The serial number of the crane and applicable attachments (i.e. luffing jib, VPC-MAX) is the only method your Manitowoc dealer or the Manitowoc Crane Care Lattice Team has of providing you with correct parts and service information.

The serial number is located on a crane identification plate attached to the operator's cab and each attachment. Refer to the Nameplate and Decal Assembly Drawing in Section 2 of this manual for the exact location of the crane identification plate.

Always furnish serial number of crane and its attachments when ordering parts or discussing service problems with your Manitowoc dealer or the Manitowoc Crane Care Lattice Team.

	⚠ WARNING
	<p>To prevent death or serious injury:</p> <ul style="list-style-type: none">• Avoid unsafe operation and maintenance. Crane and attachments must be operated and maintained by trained and experienced personnel. Manitowoc is not responsible for qualifying these personnel.• Do not operate or work on crane or attachments without first reading and understanding instructions contained in Operator Information Manual and Service Manual supplied with crane and applicable attachments.• Store Operator Information Manual and Service Manual in operator's cab. <p>If Operator Information Manual or Service Manual is missing from cab, contact your Manitowoc dealer for a new one.</p>

THE ORIGINAL LANGUAGE OF THIS PUBLICATION IS ENGLISH

See end of this manual for Alphabetical Index

SECTION 1	Introduction
Crane Data	1-1
Crane Weights	1-1
Outline Dimensions	1-1
Change of Ownership Registration	1-1
Manitowoc Dealer	1-1
Crane/Attachment Identification	1-1
Crane Orientation	1-1
Identification and Location of Components	1-2
English and Metric Conversions	1-4
Direct Conversion	1-4
Inverse Conversion	1-4
SECTION 2	Safety Information
Continuous Innovation	2-1
Nameplates and Decals	2-1
Safety Messages	2-1
General	2-1
Safety Alert Symbol	2-1
Signal Words	2-1
Symbol Identification	2-1
Safety and Information Signs	2-3
Maintaining Signs	2-3
Ordering Signs	2-3
Crane Access Points	2-4
General	2-4
Getting On or Off Crane	2-4
Personal Fall-Protection	2-9
Operator Manual/Capacity Chart Storage	2-10
General	2-10
Storing Manuals	2-10
Safe Operating Practices	2-11
General	2-11
Read Operator Manual	2-11
Operator Qualifications	2-11
Operator Conduct	2-11
Handling Load	2-13
Signals	2-16
Safety Devices	2-17
Operational Aids	2-17
Category 1 Operational Aids	2-17
Category 2 Operational Aids	2-18
Assembling, Disassembling, or Operating Crane Near Electric Power and Transmission Lines	2-19
Electrocution Hazard	2-19
Set-Up and Operation	2-19
Electrocution Hazard Devices	2-20
Electrical Contact	2-20
Refueling	2-21
Fire Extinguishers	2-21
Accidents	2-21
Safe Maintenance	2-21
Maintenance Instructions	2-21
Safe Maintenance Practices	2-21
Environmental Protection	2-23
Boom Disassembly Safety	2-25

General	2-25
Location	2-25
Pin Removal	2-25
Disassembly Precaution	2-25
Personnel Handling Policy	2-26
Pedestal/Barge Mounted Cranes	2-27
Pedestal Mounted Crane	2-28
Barge Mounted Crane	2-28
Capacity Charts for Barge Mounted Crane	2-29
Shock Loading Caused by Barge Dynamics	2-29
Operation on Barge	2-29
Barge Mount Definitions	2-30
Inspection of Barge-Mounted Crane	2-30
Transporting Crane on Barge	2-30

SECTION 3 Operating Controls And Procedures

Standard Hand Signals for Controlling Crane Operations	3-2
Operating Controls and Procedures	3-3
Operating Precautions	3-3
Auxiliary Frame Assembly Operating Positions	3-5

SECTION 4 Set-Up and Installation

General Set-Up and Installation	4-1
General Safety	4-1
Crane Orientation	4-2
Boom and Jib Assembly Drawings	4-2
Accessing Parts	4-2
Personal Fall-Protection	4-2
Handling Components	4-2
Assist Crane Requirements	4-3
Crane Weights and Shipping Data	4-3
Parts Box	4-3
Lifting Slings and Shackles	4-3
Retaining Connecting Pins	4-3
Remote Control	4-6
Activating Remote Control	4-7
Starting Engine with Remote Control	4-7
Crane and VPC-MAX Setup	4-7
Pin and Connecting Hole Cleanliness	4-8
Hose and Cable Cleanliness	4-8
Hydraulic Hose Identification	4-8
Connecting/Disconnecting Hydraulic Hoses and Electric Cables	4-8
Tightening Hydraulic Couplers	4-8
Operating Conditions During Assembly and Disassembly	4-11
Installing VPC-MAX Beam and Trolley	4-13
Prepare Crane	4-13
Check VPC Trolley Travel Limits and Calibration	4-13
Prepare VPC Trolley	4-15
Store Exhaust Shield on Crane	4-15
Remove VPC-MAX Beam from Trailer	4-17
Unfold VPC-MAX Beam	4-19
Remove Handrails from VPC-MAX Beam	4-21
Attach VPC-MAX Beam to VPC Trolley	4-23
Connect VPC-MAX Beam-to-VPC Trolley Electric Cable	4-27
Connect VPC-MAX Beam-to-VPC Trolley Hydraulic Hoses	4-27
Hook VPC-MAX Beam to Rotating Bed	4-29

Remove Counterweight Tray from Trailer	4-31
Prepare Counterweight Tray	4-31
Remove VPC-MAX Trolley from Trailer	4-33
Adjust VPC-MAX Trolley Wear Pads	4-33
Adjust VPC-MAX Trolley Scrapers	4-33
Install Trolley Installation Guides	4-35
Attach VPC-MAX Trolley to Counterweight Tray	4-37
Install VPC-MAX Trolley and Counterweight Tray	4-39
Connect VPC-MAX Energy Chain to VPC-MAX Trolley	4-41
Connect VPC-MAX Trolley Electric Cables	4-41
Connect VPC-MAX Trolley Hydraulic Hoses	4-41
Check VPC-MAX Trolley Travel Limits and Calibration	4-43
Install Auxiliary Frame Assembly	4-43
Install Handrails	4-45
Install VPC-MAX Beam Ladder	4-47
Position Counterweight Tray In Minimum Position	4-49
Calibrate Position of VPC-MAX Trolley	4-49
Installing VPC-MAX #503 Fixed Mast	4-51
Remove Fixed Mast Butt and Top Assembly from Trailer	4-51
Verify Mast Stop Accumulator Pressure	4-51
Raise Mast Stops	4-51
Connect Fixed Mast Butt and Top Assembly to Crane	4-53
Connect Fixed Mast Hydraulic Hoses	4-55
Connect Fixed Mast Electric Cable	4-55
Connect Fixed Mast Camera Cables	4-55
Disconnect Fixed Mast Top from Fixed Mast Butt	4-57
Assemble and Install Fixed Mast Inserts	4-59
Store Handling Pendants	4-61
Store Self-Erect Cylinder	4-61
Connect Straps at Mast Top	4-63
Test Mast Stop Limit Switch	4-63
Connect Straps at Mast Inserts	4-65
Connect Straps at Mast Butt	4-67
Connect Live Mast Straps to Fixed Mast	4-68
Lower Live Mast Assist Arms	4-69
Configure Fixed Mast in RCL/RCI Display	4-69
Fixed Mast Raising Methods	4-71
Target Tension During Fixed Mast Raising and Lowering	4-71
Raising Fixed Mast — Preferred Method with Boom Holdback	4-73
Disconnect Boom Hoist Equalizer from Mast Top	4-73
Raise Fixed Mast to Boom Rigging Position	4-73
Install Counterweight Boxes	4-75
Assemble Partial Boom	4-75
Install Partial Boom	4-77
Assemble Remaining Boom Sections	4-79
Connect Boom Straps	4-79
Connect Boom Sections	4-81
Finish Assembling Boom	4-81
Connect Equalizer Links to Boom Straps	4-83
Raise Fixed Mast to Operating Position	4-83
Adjust Fixed Mast and Beam Position	4-85
Raise Boom	4-85
Raising Fixed Mast — Alternate Method with Anchored Holdback	4-86
Disconnect Boom Hoist Equalizer from Mast Top	4-86
Anchor Boom Hoist Equalizer to Holdback	4-87
Raise Fixed Mast	4-87
Install Boom	4-91

Install Boom Hoist Equalizer on Equalizer Rails	4-91
Connect Equalizer Links to Boom Straps	4-91
Install Counterweight Boxes	4-91
Adjust Fixed Mast and Beam Position	4-91
Raise Boom	4-91
Raising Boom	4-92
Pre-Raising Checks	4-92
Boom Raising Procedure	4-93
Auxiliary Frame Operating Positions	4-95
Shipping Crane Components	4-97
Lowering Boom	4-97
Fixed Mast Lowering Methods	4-99
Lowering Fixed Mast — Preferred Method with Boom Holdback	4-99
Disconnect Counterweight Straps	4-99
Lower Fixed Mast to Disassembly Position	4-101
Disconnect Equalizer Links from Boom Straps	4-101
Prepare Boom for Removal	4-101
Disconnect Boom Sections	4-103
Disconnect Boom Straps	4-105
Disassemble Boom Sections	4-105
Remove Partial Boom	4-107
Disassemble Partial Boom	4-109
Remove Counterweight Boxes	4-109
Lower Fixed Mast to Disassembly Position	4-109
Connect Boom Hoist Equalizer to Mast Top	4-109
Lowering Fixed Mast — Alternate Method with Anchored Holdback	4-111
Remove Counterweight Boxes	4-111
Remove Boom Hoist Equalizer from Equalizer Rails	4-111
Remove Boom	4-111
Anchor Boom Hoist Equalizer to Holdback	4-113
Disconnect Counterweight Straps	4-113
Lower Fixed Mast	4-113
Connect Boom Hoist Equalizer to Mast Top	4-113
Removing VPC-MAX #503 Fixed Mast	4-115
Raise Live Mast Assist Arms	4-115
Configure Live Mast in RCL/RCI	4-115
Disconnect Live Mast Straps from Fixed Mast	4-115
Disconnect and Store Straps at Mast Top	4-117
Disconnect and Store Straps at Mast Inserts	4-119
Disconnect and Store Straps at Mast Butt	4-121
Deploy Self-Erect Cylinder	4-123
Connect Handling Pendants	4-123
Store Load Lines	4-125
Remove Fixed Mast Top	4-125
Remove and Disassemble Fixed Mast Inserts	4-125
Connect Fixed Mast Top to Fixed Mast Butt	4-127
Disconnect Fixed Mast Hydraulic Hoses	4-129
Disconnect Fixed Mast Electric Cable	4-129
Disconnect Fixed Mast Camera Cables	4-129
Disconnect Fixed Mast Butt and Top Assembly from Crane	4-131
Lower Mast Stops	4-133
Install Fixed Mast Butt and Top Assembly on Trailer	4-133
Removing VPC-MAX Beam and Trolley	4-135
Remove Handrails	4-135
Remove Auxiliary Frame Assembly	4-137
Install Hose/Cable Storage Brackets	4-139
Position VPC-MAX Trolley at End of Beam	4-141

Attach Lifting Slings to Counterweight Tray	4-141
Install Trolley Installation Guides	4-143
Disengage Trolley Drive Pinions from Gear Racks	4-145
Disconnect VPC-MAX Trolley Hydraulic Hoses	4-147
Disconnect VPC-MAX Trolley Electric Cables	4-147
Disconnect VPC-MAX Energy Chain from VPC-MAX Trolley	4-147
Remove VPC-MAX Trolley and Counterweight Tray	4-149
Remove VPC-MAX Trolley from Counterweight Tray	4-151
Install Counterweight Tray on Trailer	4-151
Unhook VPC-MAX Beam from Rotating Bed	4-153
Disconnect VPC-MAX Beam-to-VPC Trolley Electric Cable	4-155
Disconnect VPC-MAX Beam-to-VPC Trolley Hydraulic Hoses	4-155
Disconnect VPC-MAX Beam from VPC Trolley	4-157
Store Handrails in VPC-MAX Beam	4-159
Fold VPC-MAX Beam for Shipping	4-161
Install VPC-MAX Beam on a Trailer	4-163
Complete Disassembly	4-163
Wire Rope Installation	4-163

SECTION 5. Lubrication

Lubrication	5-1
Lube and Coolant Product Guide	5-1

SECTION 6. Maintenance

Boom and Luffing Jib Angle Indicator Calibration	6-1
Automatic Boom Stop Adjustment	6-1
Maintenance	6-1
Adjusting Automatic Boom Stop	6-3
Replacing Boom Stop Limit Switch Actuator Rod	6-3
Block-Up Limit Installation and Adjustment	6-5
General	6-5
Removing Luffing Jib	6-5
Maintenance	6-7
Adjustment	6-7
Boom Hoist Pawl Adjustment	6-9
Limit Switch Adjustment	6-9
Return Spring Adjustment	6-9
Cam Lubrication	6-9
Boom Hoist Pressure Roller Adjustment	6-10
Mast Stop Pressure Check	6-11
Mast Stop Limit Switch Check	6-11
VPC Trolley Limit Switch Checks	6-13
VPC-MAX Beam Limit Switch Checks	6-15
VPC-MAX Trolley Limit Switch Checks	6-17
VPC-MAX Beam-on-Hook Limit Switch Adjustment	6-19

THIS PAGE INTENTIONALLY LEFT BLANK

SECTION 1 INTRODUCTION

TABLE OF CONTENTS

Crane Data	1-1
Crane Weights	1-1
Outline Dimensions	1-1
Change of Ownership Registration	1-1
Manitowoc Dealer	1-1
Crane/Attachment Identification	1-1
Crane Orientation	1-1
Identification and Location of Components	1-2
English and Metric Conversions	1-4
Direct Conversion	1-4
Inverse Conversion	1-4

FOR REFERENCE ONLY

THIS PAGE INTENTIONALLY LEFT BLANK

FOR REFERENCE ONLY



SECTION 1 INTRODUCTION

CRANE DATA

See the end of this section for crane data specific to your crane:

- Basic Specifications
- EC Declaration (if applicable)

CRANE WEIGHTS

See the end of this section for crane weights.

OUTLINE DIMENSIONS

See the end of this section for outline dimensions.

CHANGE OF OWNERSHIP REGISTRATION

If you are the new owner of a Manitowoc crane, please register it with Manitowoc Crane Care so we can contact you if the need arises.

1. Go to www.manitowoccranes.com.
2. Go to Parts & Service > Service Support > Change of Ownership Form.
3. Complete the form.

MANITOWOC DEALER

For questions about this manual or the MLC300 crane, contact your Manitowoc dealer. If you do not know the contact information for your dealer, locate the Manitowoc dealer nearest you, as follows:

1. Go to www.manitowoccranes.com
2. Go to Dealer Locator.
3. Follow the on-screen prompts to locate your Manitowoc dealer.

CRANE/ATTACHMENT IDENTIFICATION

An identification plate is attached to the outside of the operator cab (see [Figure 1-1](#)) and to the attachments (for example, luffing jib and VPC-MAX).

The crane or attachment model and serial number are provided on the plate.

For the exact location of the identification labels on your crane and attachments, refer to the Nameplates and Decals Drawing in Section 2 of this manual.

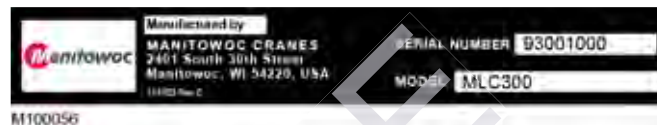
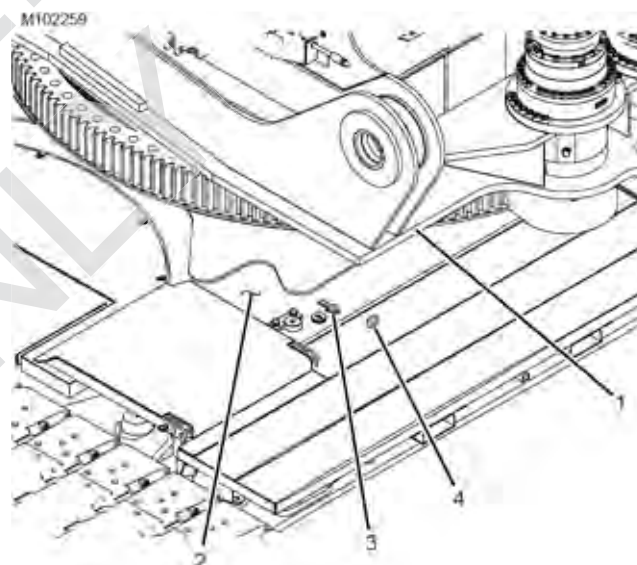

Figure 1-1. Identification Plate

CRANE ORIENTATION

The terms RIGHT, LEFT, FRONT, REAR used in this manual refer to operator's right, left, front, and rear sides when seated in the operator cab looking forward.

- The swing drives are on the front of the rotating bed.
- The operator cab is on the left side of the rotating bed.
- A yellow arrow (3) and dot (4) on the right top and right front sides of the carbody indicate the FRONT of the carbody.



Item	Description
1	Carbody
2	Yellow Arrow on Front of Carbody
2	Yellow Dot on Front of Carbody
3	Front of Rotating Bed
4	Swing Drive

Figure 1-2. Carbody Orientation Arrow

IDENTIFICATION AND LOCATION OF COMPONENTS

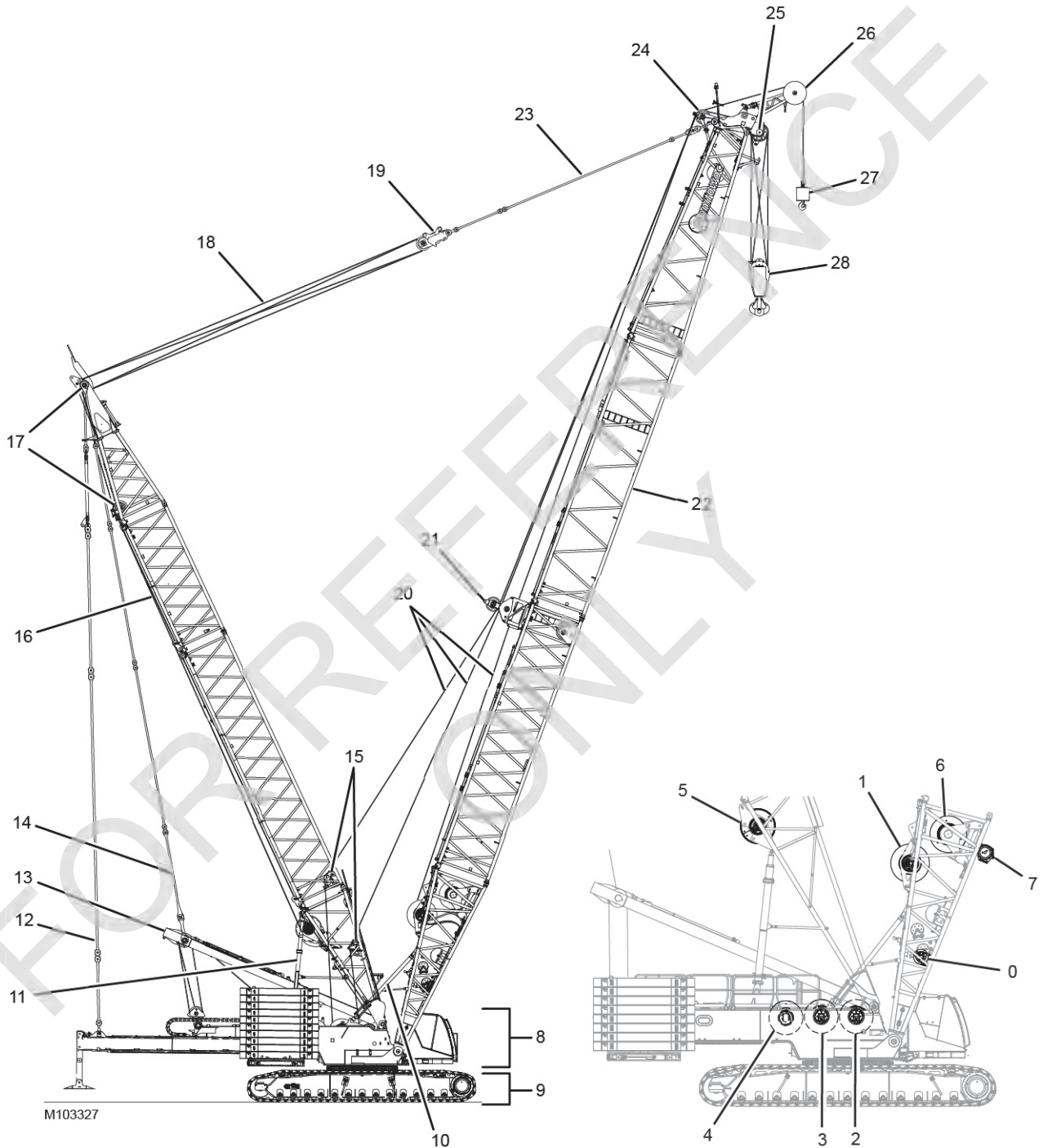

Figure 1-3. Overall View

Item	Description	Item	Description	Item	Description
0	Drum 0 (rigging winch)	12	Counterweight Straps	24	Boom Top Wire Rope Guide
1	Drum 1 (main hoist)	13	Live Mast	25	Lower Boom Point
2	Drum 2 (auxiliary front hoist)	14	Mast Straps	26	Upper Boom Point
3	Drum 3 (auxiliary rear hoist)	15	Load Drum Wire Rope Guides	27	Load Block
4	Drum 4 (mast hoist)	16	#503 Fixed Mast	28	Hook-and-Weight Ball
5	Drum 5 (Boom hoist)	17	Boom Hoist Wire Rope Guides	29	VPC Trolley
6	Drum 6 (luffing or auxiliary hoist)	18	Boom Hoist Wire Rope Reeving	30	VPC-MAX Beam Assembly
7	Drum 7 (tagline)	19	Equalizer	31	VPC-MAX Trolley
8	Upperworks	20	Load Lines	32	Counterweight Tray
9	Lowerworks	21	Load Drum Wire Rope Guides	33	Counterweight Boxes
10	Physical Boom Stop	22	#500 Boom	34	Auxiliary Frame Assembly
11	Physical Mast Stop	23	Boom Straps		

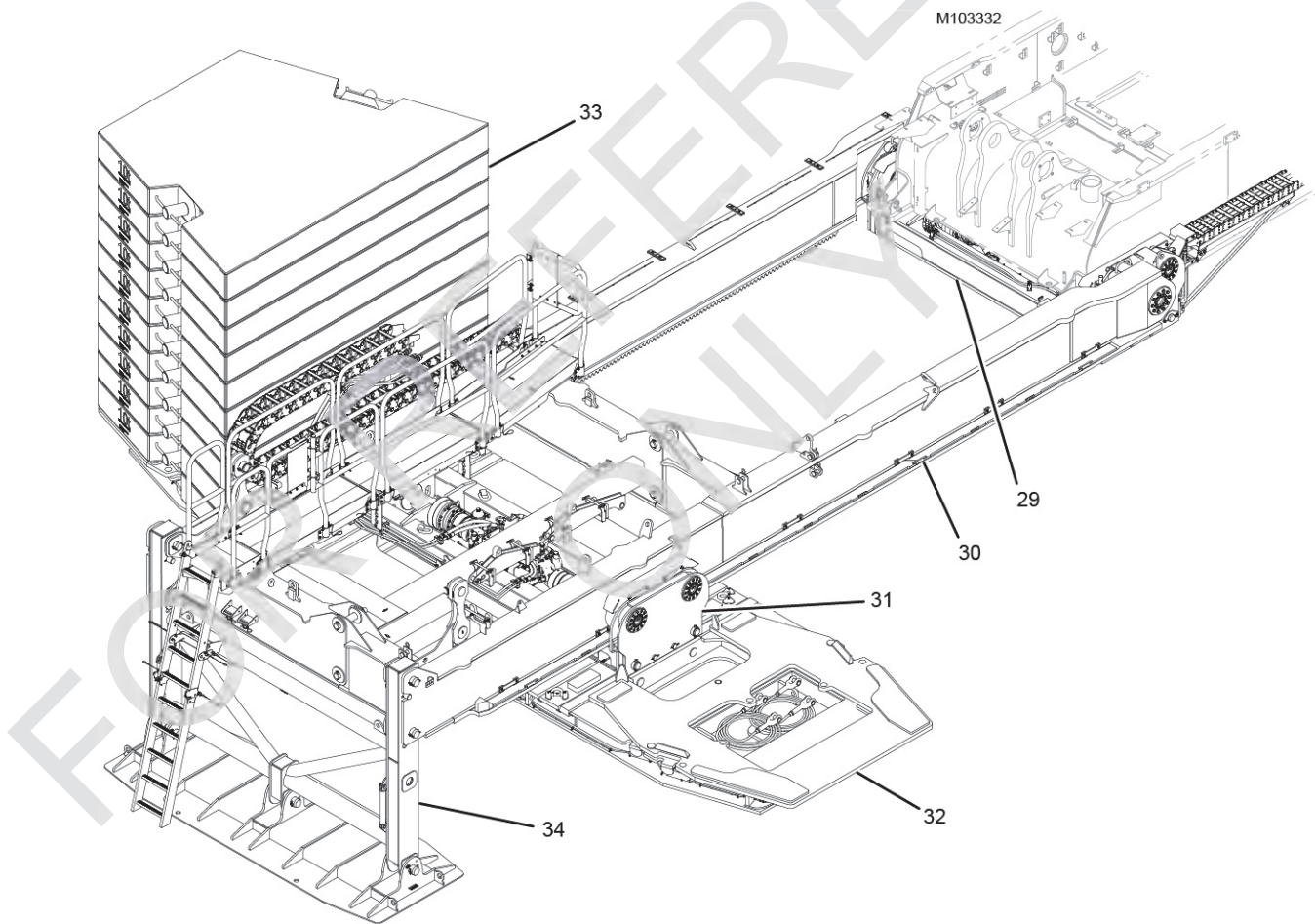

FIGURE 1-3 continued

ENGLISH AND METRIC CONVERSIONS

Direct Conversion

MULTIPLY (x) known value by conversion factor to obtain equivalent value in desired units. For example, 12 ft is converted to meters (m), as follows:

$$12 \text{ ft} \times 0.3048 = 3,6576 \text{ m}$$

Inverse Conversion

DIVIDE (÷) known value by conversion factor to obtain equivalent value in desired units. For example, 3,6576 m is converted to feet, as follows:

$$3,6576 \text{ m} \div 0.3048 = 12$$

To Convert	Symbol	Application	To	Symbol	Multiply By
Square Inch	in ²	Filter Area Clutch Contact	Square Centimeter	cm ²	6.4516
Square Foot	ft ²	Ground Contact	Square Meter	m ²	0.0929
Pound Force	lb	Pedal Effort	KiloNewton Newton	kN N	0.00445 4.4482
Pound Force	lb	Line Pull	KiloNewton	kN	0.00445
Pound Force Per Inch	lb/in.	Spring Force	Newton per millimeter	Nmm	0.1751
Pound Force Per Foot	lb/ft		Newton per meter	Nm	14.5939
Inch	in.	Adjustments	Millimeter	mm	25.4000
Foot	ft	Outline Dimensions	Meter	m	0.3048
Mile	miles	Travel Distance	Kilometer	km	1.6093
Horsepower	hp	Engine	Kilowatt	kW	0.7457
Pound/Sq. In.	psi	Hydraulic & Air	Bar		0.0689
Degrees Fahrenheit	°F	Oil, Air, Etc.	Degrees Centigrade	°C	°F - 32 ÷ 1.8
Degrees Centigrade	°C		Degrees Fahrenheit	°F	°C x 1.8 + 32
Inch Pound	in lb	Bolt Torque	Newton Meter	Nm	0.1129
Foot Pound	ft lb		Newton Meter	Nm	1.3558
Miles Per Hour	mph	Vehicle Speed	Kilometers Per Hour	km/h	1.6093
Miles Per Hour	mph	Wind Speed	Meters Per Second	m/s	0.4470
Feet Per Minute	fpm	Line Speed	Meters Per Minute	m/min	0.3048
Cubic Yard	yd ³	Bucket Capacity	Cubic Meter	m ³	0.7646
Cubic Foot	ft ³		Cubic Meter	m ³	0.0283
Cubic Inch	in ³	Pump Displacement	Cubic Centimeter	cm ³	16.3871
VOLUME (LIQUID)					

To Convert	Symbol	Application	To	Symbol	Multiply By
Ounce	oz	Fluid Capacities	Milliliter	mL	29.5735
Pint	pt		Liter	L	0.4732
Quart	qt		Liter	L	0.9464
Gallon	gal		Liter	L	3.7854
Gallon Per Minute	gpm	Pump Flow	Liters Per Minute	L/min	3.7854
Pound	lb	Unit/Component	Kilogram	kg	0.4536
Ton (2,000 lb.)	USt	Load Ratings	Metric Ton	t	0.9072
Ton (2,000 lb.)	USt		Kilogram	kg	907.1847

FOR REFERENCE ONLY

THIS PAGE INTENTIONALLY LEFT BLANK

FOR REFERENCE ONLY

SECTION 2

SAFETY INFORMATION

TABLE OF CONTENTS

Continuous Innovation	2-1
Nameplates and Decals	2-1
Safety Messages	2-1
General	2-1
Safety Alert Symbol	2-1
Signal Words	2-1
Symbol Identification	2-1
Safety and Information Signs	2-3
Maintaining Signs	2-3
Ordering Signs	2-3
Crane Access Points	2-4
General	2-4
Getting On or Off Crane	2-4
Personal Fall-Protection	2-9
Operator Manual/Capacity Chart Storage	2-10
General	2-10
Storing Manuals	2-10
Safe Operating Practices	2-11
General	2-11
Read Operator Manual	2-11
Operator Qualifications	2-11
Operator Conduct	2-11
Handling Load	2-13
Size of Load	2-13
Attaching Load	2-13
Lifting/Moving Load	2-14
Multiple Load Line Operation	2-15
Holding Load	2-16
Signals	2-16
Safety Devices	2-17
Operational Aids	2-17
Category 1 Operational Aids	2-17
Category 2 Operational Aids	2-18
Assembling, Disassembling, or Operating Crane Near Electric Power and Transmission Lines	2-19
Electrocution Hazard	2-19
Set-Up and Operation	2-19
Electrocution Hazard Devices	2-20
Electrical Contact	2-20
Refueling	2-21
Fire Extinguishers	2-21
Accidents	2-21
Safe Maintenance	2-21
Maintenance Instructions	2-21
Safe Maintenance Practices	2-21
Environmental Protection	2-23
Boom Disassembly Safety	2-25
General	2-25
Location	2-25
Pin Removal	2-25
Disassembly Precaution	2-25
Personnel Handling Policy	2-26

- Pedestal/Barge Mounted Cranes 2-27
 - Pedestal Mounted Crane 2-28
 - Definition 2-28
 - Examples 2-28
 - Barge Mounted Crane 2-28
 - Definition 2-28
 - Examples 2-28
- Capacity Charts for Barge Mounted Crane 2-29
- Shock Loading Caused by Barge Dynamics 2-29
- Operation on Barge 2-29
- Barge Mount Definitions 2-30
- Inspection of Barge-Mounted Crane. 2-30
- Transporting Crane on Barge 2-30

FOR REFERENCE ONLY



SECTION 2

SAFETY INFORMATION



WARNING

California Proposition 65

Breathing diesel engine exhaust exposes you to chemicals known to the State of California to cause cancer and birth defects or other reproductive harm.

- Always start and operate the engine in a well-ventilated area.
- If in an enclosed area, vent the exhaust to the outside.
- Do not modify or tamper with the exhaust system.
- Do not idle the engine except as necessary.

For more information go to www.P65warnings.ca.gov/diesel.

Batteries, battery posts, terminals, and related accessories can expose you to chemicals, including lead and lead compounds, which are known to the State of California to cause cancer and birth defects or other reproductive harm. Wash hands after handling. For more information go to www.P65warnings.ca.gov.

California Spark Arrestor

Operation of this equipment may create sparks that can start fires around dry vegetation. A spark arrestor may be required. The owner/operator should contact local fire agencies for laws or regulations relating to fire prevention requirements.

CONTINUOUS INNOVATION

Due to continuing product innovation, the information in this manual is subject to change without notice. If you are in doubt about any procedure, contact your Manitowoc dealer or the Manitowoc Crane Care Lattice Team.

NAMEPLATES AND DECALS

See drawing at the end of this section.

SAFETY MESSAGES

General

The importance of safe operation and maintenance cannot be over emphasized. Carelessness or neglect on the part of operators, job supervisors and planners, rigging personnel,

and job site workers can result in their death or injury and costly damage to the crane and property.

To alert personnel to hazardous operating practices and maintenance procedures, safety messages are used throughout the manual. Each safety message contains a safety alert symbol and a signal word to identify the hazard's degree of seriousness.

Safety Alert Symbol



This is the safety alert symbol. It is used to alert you to potential personal injury hazards. **Obey all safety messages that follow this symbol to avoid possible death or injury.**

Signal Words



DANGER

Indicates a hazardous situation which, if not avoided, will result in death or serious injury.



WARNING

Indicates a hazardous situation which, if not avoided, could result in death or serious injury.



CAUTION

Used with the safety alert symbol, indicates a hazardous situation which, if not avoided, could result in minor or moderate injury.

CAUTION

Without the safety alert symbol, identifies potential hazards that could result in property damage.

NOTE Highlights operation or maintenance procedures.

Symbol Identification

Many of the symbols used in the safety and information signs and nameplates on this crane are identified in [Table 2-1 on page 2-2](#) and [Table 2-2 on page 2-3](#).

Table 2-1 Common Safety Symbols

Cut or Crush Hazards					Cut Hazard
 M100090	 M100091	 M100066	 M100065	 M100069	 M100067
Crush Hazards					Fire Extinguisher
 M100070	 M100071	 M100072	 M100073	 M100074	 M100082
Fall Hazards			Falling Boom (Crush) Hazards		Explosion Hazard
 M100083	 M100084	 M100085	 M100068	 M100075	 M100080
Falling Load Hazards		Flying Objects Hazards		Overhead Obstruction Hazard	Pressure Release Hazard
 M100076	 M100077	 M100088	 M100088	 M100089	 M100081
Electrocution Hazards		Personal Fall Protection	Pressure Cleaning	Sound Power Level	Read Manual
 M100078	 M100079	 M100095	 M100087	 M100096	 M100093

Table 2-1 Common Safety Symbols









Emergency Cab Exit				
 <p>M100246C</p>				

Table 2-2 Miscellaneous Symbols

Diesel Fuel	Engine Coolant	Engine Coolant Vent	Engine Oil Level	Hydraulic Filter	Hydraulic Oil
 <p>M100271</p>	 <p>M100267</p>	 <p>M100268</p>	 <p>M100269</p>	 <p>M100272</p>	 <p>M100273</p>
<p>Pump Drive Oil Level</p>	<p>Tire Pressure (if equipped)</p>				
 <p>M100270</p>	 <p>M100266</p>				

SAFETY AND INFORMATION SIGNS

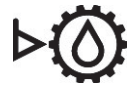
Maintaining Signs

The crane owner/user shall make sure that all safety and information signs are legible and installed at the proper locations on the crane. If a sign has been defaced or removed, it must be replaced immediately. See the Nameplate and Decal Drawing at the end of this section for the installation locations of signs.

Ordering Signs

Order replacement safety and information signs from your Manitowoc dealer.

When ordering a sign, give the crane model number, the crane serial number, and the name and part number on the sign.

CRANE ACCESS POINTS



WARNING

Crush Hazard!

The upperworks can swing into and crush personnel climbing on or off the crane.

Moving crawlers can crush personnel climbing on or off the crane.

To prevent death or serious injury:

- Barricade all accessible areas to the crane so personnel cannot be struck or crushed when the upperworks is swung.
- Do not climb onto or off the crane while the upperworks is being swung or the crane is being traveled.
- Signal the operator for permission to climb onto/off the crane.
- Operator: do not swing or travel while personnel are climbing onto or off the crane. Stop the swing and travel motions. Apply the swing brake and turn on travel park.
- Operator: Always sound the horn to alert personnel before you swing or travel.
- Automatic alarms will sound to alert personnel when the crane is swung or traveled and when the VPC (variable position counterweight) is moving.

NOTE If the swing, travel, and VPC alarms are not operating properly, they must be repaired as soon as possible. Until they are repaired, the operator shall alert personnel to crane movement using the horn on the control console.

General

Take the necessary precautions to prevent slipping and/or falling off the crane during assembly, disassembly, maintenance, or other work. **Falling from any height could result in serious injury or death.**

Manitowoc has provided ladders and platforms at the locations shown in [Figure 2-1](#).

The owner/user shall provide workers with approved ladders or aerial work platforms to access those areas of the crane, mast, and boom that cannot be reached from the ground or from steps, ladders, catwalks, and platforms provided by Maniowoc.

Adhere to local, state, and federal regulations for handling personnel and for personnel fall protection.

- Access points must be kept clear to prevent personal injury and unsafe operation of the crane. Store clothing and other personal belongings so they do not interfere with controls in operator cab or with operation of the crane.
- Do not allow ground personnel to store their personal belongings (clothing, lunch boxes, water coolers, and the like) on the crane.
This practice will prevent ground personnel from being crushed or electrocuted when they attempt to access personal belongings stored on the crane.
- Tools, oil cans, spare parts, and other necessary equipment must be stored in tool boxes or other appropriate locations. Do not allow these items to lie around loose in operator cab or on steps, ladders, catwalks, and platforms.
- To reduce risk of slipping, non-skid material (sand in paint) has been applied to painted walkways and platforms.
- Walkways and platforms can be slippery when wet and when oil or is grease is spilled on them. **Keep walkways and platforms clean and dry to prevent slipping on them.** When non-skid material wears out, reapply it.
- Wear shoes with a highly slip-resistant sole material. Clean any mud or debris from shoes before entering the crane cab or climbing onto the cab. A shoe that is not clean might slip off a control pedal during operation.
- Do not make modifications or additions to the crane's access system that have not been evaluated and approved by Maniowoc.

GETTING ON OR OFF CRANE

Personnel getting on and off the crane shall do so only at the ladders provided and only **while the crane is parked**.

Never climb onto or off a moving crane. **Climb onto and off the crane only when it is parked and only with the operator's permission.**

When personnel use ladders to get on or off the crane, their hands shall be free of any objects. Objects which cannot be carried in pockets or tool belts must be lifted into place with a hand line or hoist.

Always maintain a three-point contact with the ladder: two feet and one hand, or two hands and one foot.

Item	Description
1	Operator Cab Platform with Handrails
2	Carbody Platform (both ends and sides)
3	Mast Platform
4	Engine Enclosure (non-skid)
5	Rotating Bed Handrails (both side)
6	Folding Ladder (left side only)
7	Rotating Bed Platform (both sides)
8	Counterweight Tray and Boxes (non-skid)
9	Ladder (left side only)
10	Ladder (both crawlers)
11	Catwalk (each boom and mast section)
12	Ladder (each boom section)
13	Ladder (mast butt)
14	Platform (2 on mast butt)

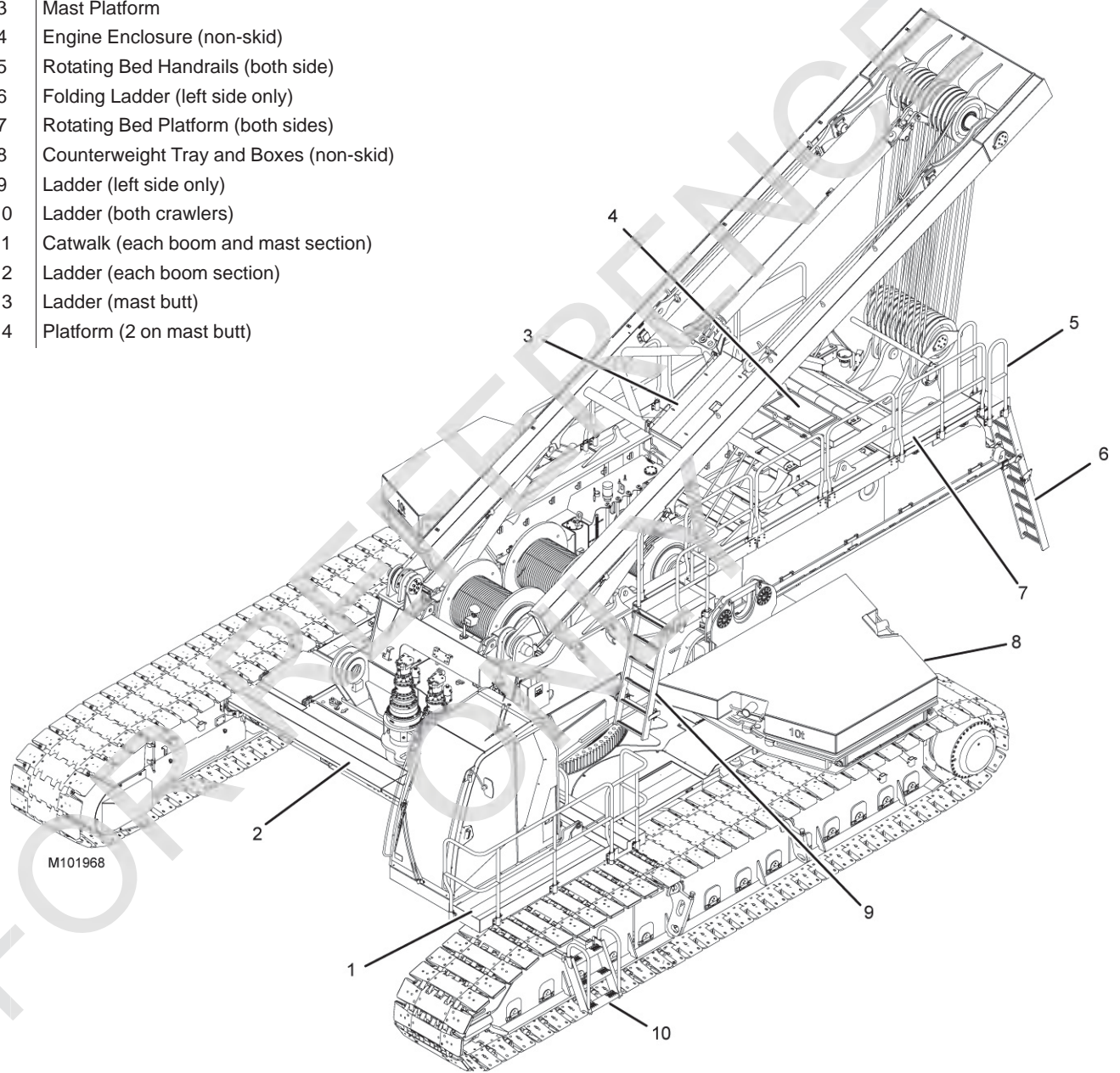

Figure 2-1. Crane Access Points

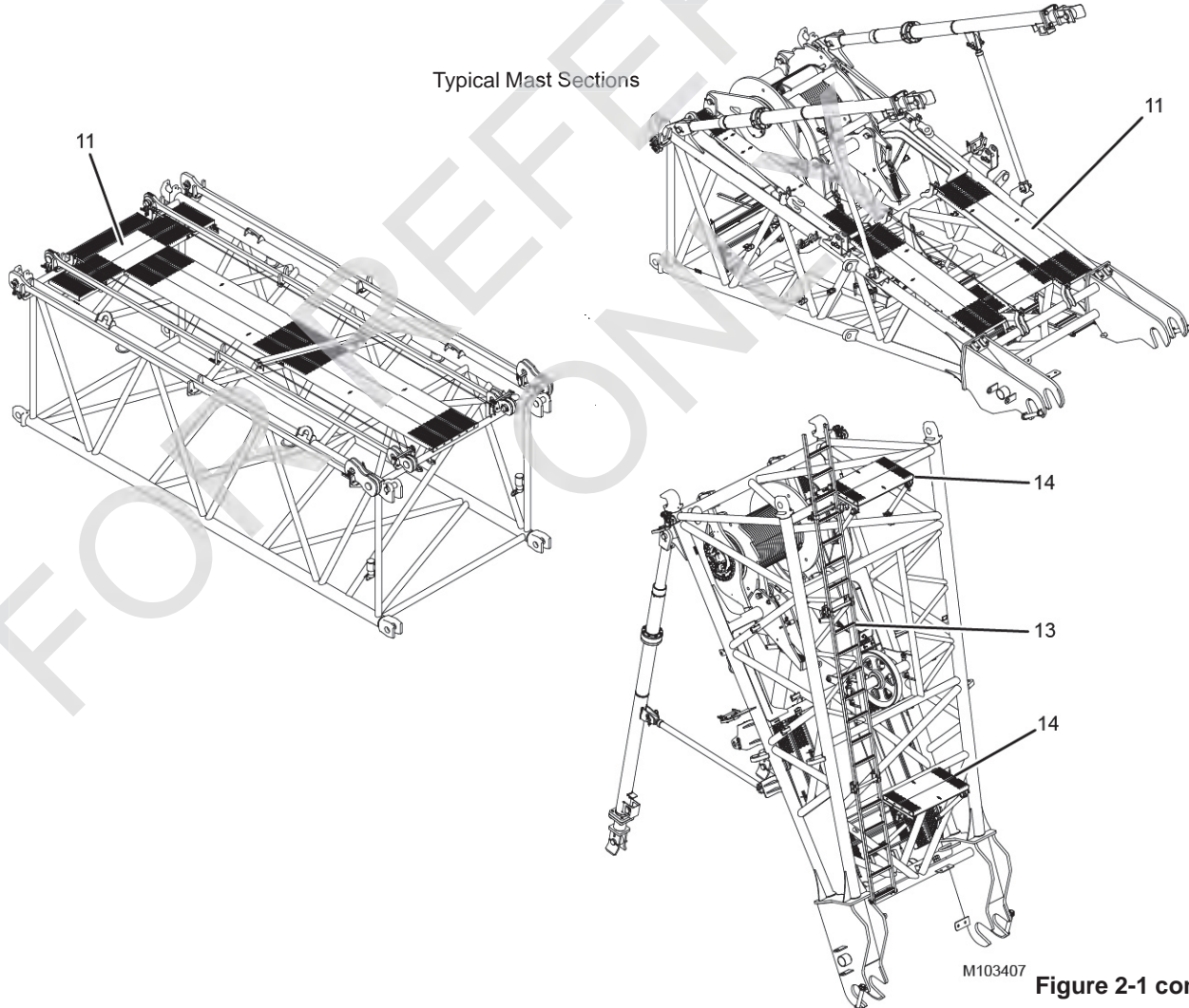
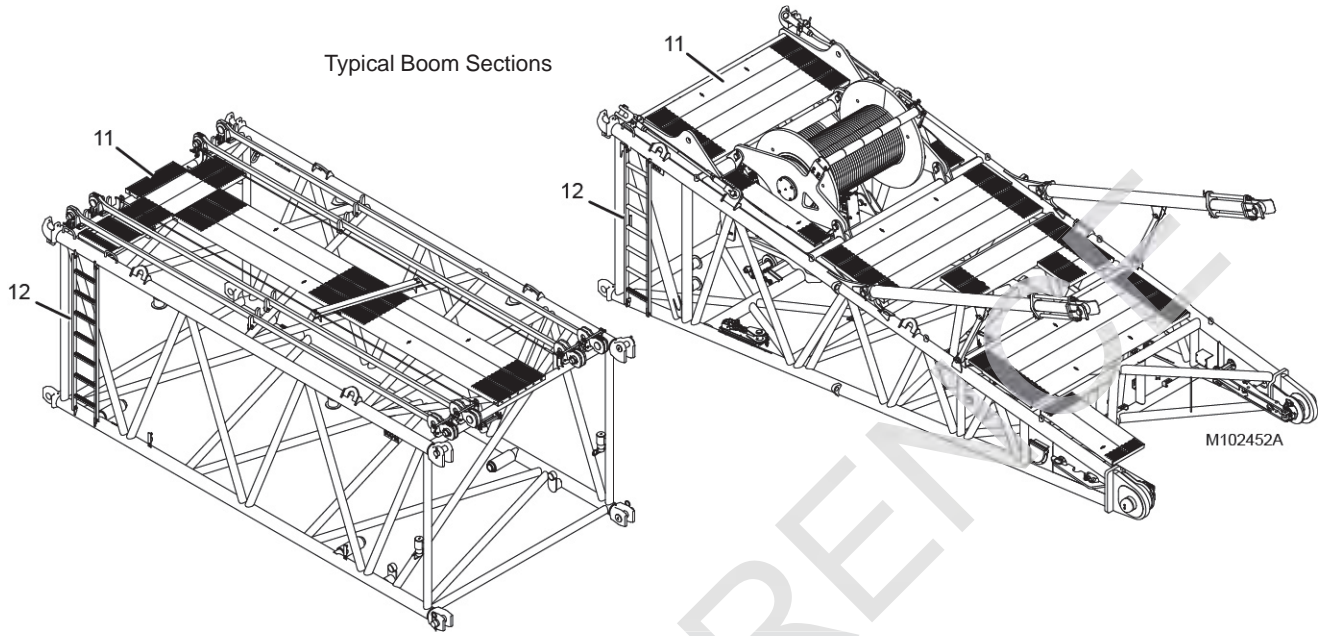

Figure 2-1 continued

Item	Description
6	Folding Ladder (left side only)
8	Counterweight Tray and Boxes (non-skid)
15	Catwalks (VPC-MAX Beam)
16	Rotating Bed Handrails (both side)

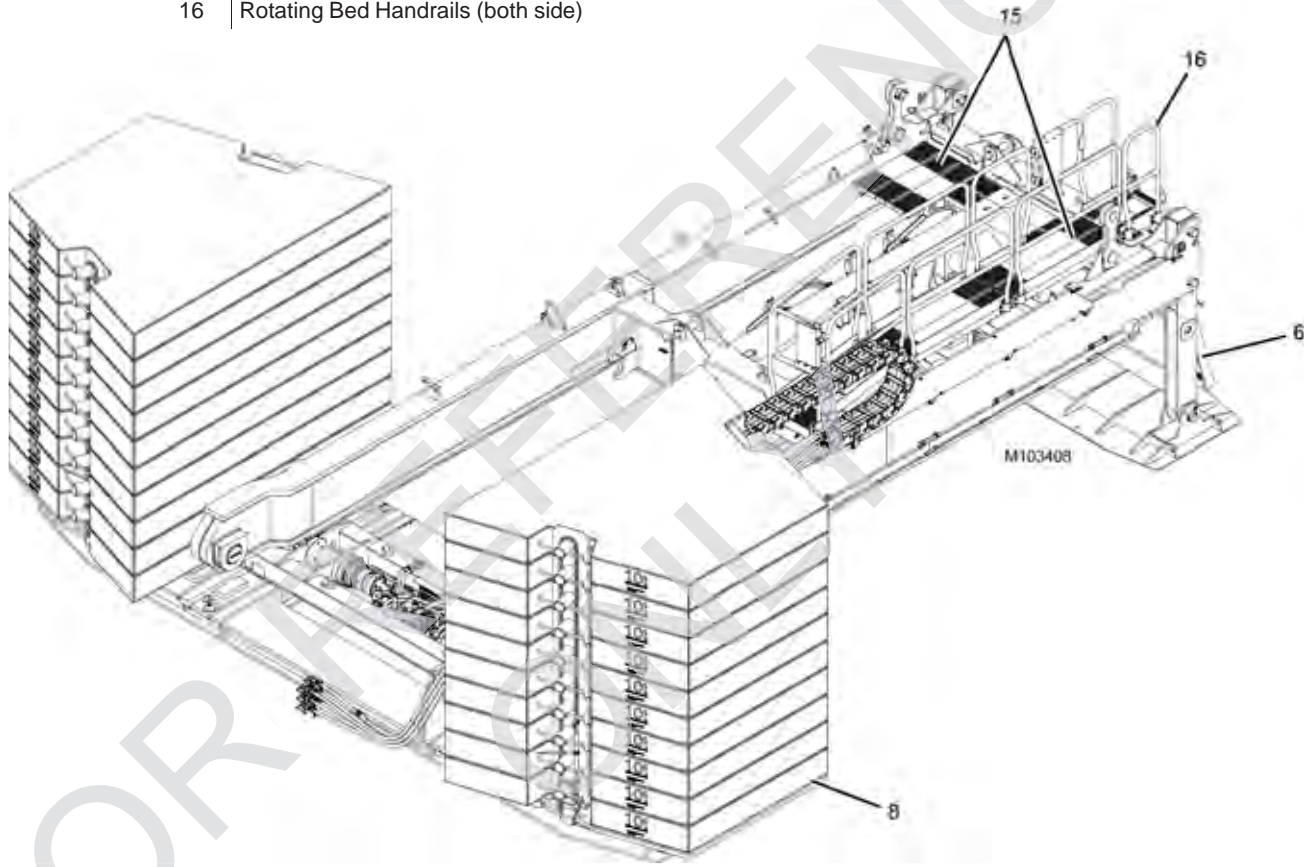

Figure 2-1 continued

THIS PAGE INTENTIONALLY LEFT BLANK

FOR REFERENCE ONLY



Item	Description
1	Lifeline
2	Anchor

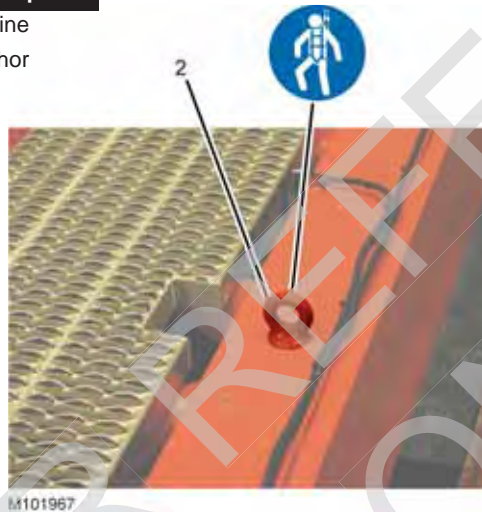

Figure 2-2. Fall Protection Lifeline and Anchor

PERSONAL FALL-PROTECTION

Manitowoc has provided lifelines and anchors throughout the crane and attachment (see [Figure 2-2.](#)) to which workers can attach their personal fall-protection equipment.

! WARNING Fall Hazard!

To prevent falling from any height during crane assembly and disassembly, personnel shall wear fall-protection equipment.

- Anchors and lifelines are designed to handle only one person at a time
- Do not use anchors for lifting or pulling loads

OPERATOR MANUAL/CAPACITY CHART STORAGE

General

Manitowoc provides the following manuals and other important literature with your crane and attachment (Luffing Jib, etc.):

- **Operator Manual (Serial Numbered)**
Contains safety information, crane specifications, assembly/erection procedures, operating instructions, lubrication and maintenance checks.
- **Parts Manual (Serial Numbered)**
Contains illustrations and part numbers of replaceable parts
- **Capacity Chart Manual (Serial Numbered)**
Contains lifting capacities and related information (wire rope specifications, drum and lagging information, etc.)
- **Maintenance Checks and Lube Guide**
Contains lists of maintenance checks and lube services and their prescribed intervals
- **RCI/RCL Operation**
Contains rated capacity indicator and/or rated capacity limiter operation, limits, and calibration procedures
- **Service Manual (Serial Numbered)**
Contains theory of operation, maintenance procedures, crane and wire rope inspection procedures, troubleshooting information, and shop procedures

The manuals which must be retained in the operator cab (Operator Manual, Capacity Charts, Maintenance Checks and Lube Guide, and RCL Operation) are supplied in an OPERATOR INFORMATION binder. A separate binder is provided for the crane and each applicable attachment.

The Operator Manuals and Capacity Charts are stamped with the serial number of the crane or attachment. The serial number on the manuals and capacity charts must match the serial number of the crane and attachment in use. **Using any other manual or capacity chart is prohibited.**

- The crane model and serial number is located on the Crane Identification Plate on the crane cab
- The model and serial number of the attachment (other than standard boom) is located on the Crane Identification Plate on the attachment

If the serial numbers of your manuals and capacity charts do not match the serial numbers of the crane or attachment, contact your Manitowoc dealer for the proper manual or capacity charts.

Do not operate crane or attachment if proper Capacity Chart is not in cab.

Storing Manuals

Store the Operator Information Manuals for the crane and each applicable attachment on the bookshelf in the operator cab (Figure 2-3).

Attach the chain from the manual in use to the link behind the operator's seat.

Keep all other manuals provided with the crane in the crane owner's/user's office so they are readily available when needed.

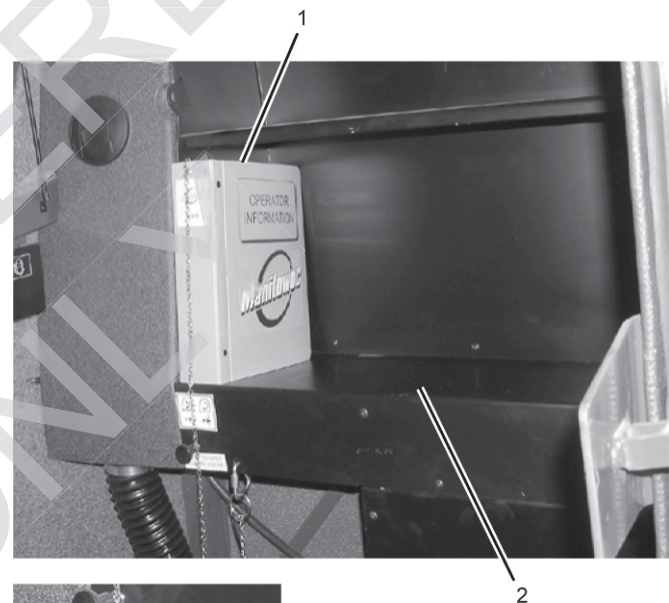

M101903

Item	Description
1	Operator Information Manual
2	Bookshelf Behind Operator Seat
3	Link
4	Chain Ring

Figure 2-3. Bookshelf in Cab

SAFE OPERATING PRACTICES

General

The importance of safe operation cannot be over emphasized. Carelessness and neglect on the part of operators, supervisors and planners, rigging personnel and job site personnel can result in their death or injury and costly damage to the crane or property.

The safety information in this publication is intended only as a guide to assist qualified operators, supervisors and planners, rigging personnel, and job site personnel in safe operation. Manitowoc cannot foresee all hazards that will arise in the field; therefore, **safety remains responsibility of crane operators and owner.**

Local, state, and other governmental agencies may require stricter operating practices. When a conflict in practices exists, follow the strictest practice.

Read Operator Manual

Safe and efficient assembly, disassembly, and operation of this crane requires that it be maintained in proper working order and that its operators and maintenance personnel be familiar with the crane's functions and capabilities.

The Operator Manual supplied with and considered part of your crane must be read and completely understood by each person responsible for assembly, disassembly, operation, and maintenance of the crane.

The Operator Manual must be read to personnel who cannot read or understand English or other language into which the manual is translated.

Because of a program of continuing improvement in product design, Manitowoc reserves the right to change the information and specifications contained in the Operator Manual at any time without notice. If you have any questions regarding the crane or its Operator Manual, please contact your Manitowoc dealer.

Operator Qualifications

The crane must be operated only by the following **qualified** personnel:

1. Designated operators.
2. Trainees under direct supervision of a designated operator.
3. Supervisors, inspectors, and maintenance or test personnel when necessary in performance of their duties. Operation of the crane by these personnel shall be limited to the crane functions needed to perform the

inspection or to verify the crane's performance after maintenance procedures.

No personnel shall be allowed to climb onto the crane or enter cab unless performance of their duties requires them to do so, and then only with knowledge of operator or other qualified person.

Qualified person is defined as one who by reason of training and experience is thoroughly familiar with crane operations and the hazards involved. Such a person shall meet the operator qualifications specified in Occupational Safety and Health Administration (OSHA) Regulations (United States Federal Law), in ASME B30.5 American National Standard, or in any other applicable federal, state, or local laws.

Operator training and qualification is crane owner's responsibility.

NOTE The regulations and standards mentioned above and later in this section can be obtained from:

US DOL/OSHA Rules and Regulations are available by mail from the Superintendent of Documents, PO Box 371954, Pittsburgh, PA, 15250-7954 or by:

- Phone 202-512-1899
- Fax 202-512-2250
- Online at www.osha.gov

ASME (formerly ANSI) B30 Series American National Standards are available by mail from the ASME, 22 Law Drive, Fairfield, New Jersey, 07004-2900 or by:

- Phone US & Canada 800-843-2763
- Phone Mexico 95-800-843-2763
- Phone Universal 973-882-1167
- Fax 973-882-1717 or 973-882-5155
- E-mail infocentral@asme.org

Operator Conduct

1. The operator shall not engage in any practice which diverts his/her attention while operating the crane.
2. The operator shall not operate the crane when he/she is physically or mentally unfit.
3. The operator shall be responsible for all operations under his/her direct control. When safety of an operation is in doubt, the operator shall stop the crane's functions in a controlled manner. Lift operations can resume only after safety concerns have been addressed or the continuation of crane operations is directed by the lift supervisor.

4. The operator shall be thoroughly familiar with operation of the crane and its proper care. If adjustments or repairs are necessary or if there are known defects that impair safe operation, the crane must not be operated until unsafe conditions have been corrected.
5. If there is a warning sign at the start controls, the operator shall not start the engine until the warning sign has been removed by the person who installed it.
6. Before starting the engine, the operator shall make sure that:
 - a. All daily inspection and maintenance services have been performed.
 - b. All controls are in off the position and all brakes and locking devices are applied or engaged.
 - c. All personnel are clear of the crane. Deploy a swing radius barrier.

**WARNING**

Safety devices and operational aids such as rated capacity indicator or limiter, boom and jib angle indicator or limiter, anti-two-block device, level indicator, swing limiter, proximity device, etc., may be installed on your crane. Such devices are to be used only as **AIDS TO ASSIST OPERATOR**; their presence on the crane in no way substitutes for or lessens requirement that operator knowledge, experience, and judgment are required to ensure safe operation of the crane.

Crane must not be loaded beyond applicable static or dynamic ratings given in Capacity Chart for crane.

- See Size of Load on [Page 13](#)
 - For a description of each safety device and operational aid, see [Safety Devices and Operational Aids](#) starting on [Page 17](#) and Section 3
7. The operator shall test all controls, limits, and communication systems at the start of each shift. Any defects found must be corrected before operation is begun.
 8. The operator shall not start crane movement if the load or designated signal person is not within his/her range of vision or communication.
 9. The operator shall understand and respond to signals from the person directing the lift or from the designated signal person. When a signal person or crane follower is not required, the operator is responsible for the lift. **Operator shall obey a stop signal at all times, no matter who gives it.**

10. The operator shall verify that the Capacity Chart being used is the correct one for the cranes configuration (boom length, load line reeving, counterweight, etc.).
11. The operator shall verify that:
 - a. All attachments are properly assembled and attached to the crane according to the rigging drawings called for in the Capacity Chart.
 - b. The counterweight — to include applicable auxiliary counterweight — is in place and of proper weight. **Maximum required counterweight must not be exceeded.**

**WARNING****Moving Load/Tipping Crane Hazard!**

Changing weather conditions including, but not limited to: wind, ice or snow accumulation, precipitation, flooding, lightning, etc. should be considered when determining the location and configuration of a crane when it will be left unattended.

12. The operator shall perform the following operations before leaving the operator cab for any reason:
 - a. Park the crane and position upperworks so the crane does not interfere with operation of other equipment.
 - b. Apply travel and swing brakes or locking devices.
 - c. Land any attached load.
 - d. Lower the boom onto blocking at ground level or onto a boom rest if possible.

If the boom cannot be lowered, as determined by a qualified designated person, it must be securely fastened from movement by wind or other outside forces (see Wind Conditions in Capacity Chart Manual).
- NOTE** The designated person shall be familiar with the job site limitations, the crane configuration, and the expected weather conditions.
- e. Move all controls to off.
 - f. Apply all drum brakes and pawls.
 - g. Disengage the master clutch, if equipped.
 - h. Stop the engine.
- NOTE** Also read Unattended Crane instructions in Section 3 of the Crane Operator Manual.
13. The operator shall perform the following operations if power or a control function fails during operation:

- a. Land all suspended loads, if possible, under brake or power control.
 - b. Apply all brakes and locking devices.
 - c. Move all controls to off.
14. If the crane will be operated at night, the operator shall make sure that there is sufficient lighting for safe operation. The load and landing area must be illuminated.
15. The operator shall not operate the crane during periods of bad weather if his/her ability to see the load or the signal person is impaired by darkness, fog, rain, snow, and the like.

Do not operate the crane with a snow or ice covered boom. The extra weight may cause overload, tipping, or structural damage.

Never operate the crane during an electrical thunderstorm.

When a local weather storm warning exists (including electrical thunderstorm), stop operation and secure the crane. See step 12 on page 2-12.

NOTE DO NOT depend on grounding. Grounding of a crane affords little or no protection from electrical hazards. The effectiveness of grounding is limited by the size of the conductor (wire) used, condition of the ground, the magnitude of voltage and current present, and numerous other factors.

16. Wind can cause the crane to tip or the boom and other attachments to collapse. The operator or qualified person directing the lift shall compensate for the effect of wind on the load and boom by reducing ratings, reducing operating speeds, or a combination of both.

Unless otherwise specified in the Capacity Chart, or Operator Manual, stop operation under the following wind conditions:

- a. If the wind causes the load to swing forward past the allowable operating radius or sideways past either boom hinge pin, land the load and apply the drum brakes.
- b. If the wind exceeds 16 m/s (35 mph), land all loads and apply the drum brakes, lower the boom onto blocking at ground level or otherwise restrain it, and apply the swing and travel brakes and/or locks.

NOTE “Land load” means to set it down on a firm uniformly supporting surface.

17. Booms, jibs, or masts which are being assembled or disassembled on the ground (with or without support of

boom rigging) must be securely blocked to prevent the boom, jib, or mast sections from dropping.

Workers shall not go under boom, jib, or mast sections when removing connecting pins or bolts.

18. Each outrigger must be visible to the operator or the signal person during extension and retraction.

Handling Load

Size of Load

1. The crane must not be loaded beyond the applicable static or dynamic ratings given in the Capacity Chart for the crane configuration.

NOTE Capacity charts for Manitowoc cranes show the total weight of freely suspended loads for various boom and jib lengths and operating radii.

“**Freely suspended load**” is a load that is hanging free with no direct external force applied except by the crane’s load-line reeving.

To determine the actual weight of the load which can be lifted at a given radius (working load), the operator shall deduct the weight of certain lifting equipment from the total weight given in the chart. See the specific Capacity Chart for your crane for a list of lifting equipment which must be deducted.

The operator’s judgment shall be used to further reduce total load to allow for the dynamic effects of swinging, hoisting, or lowering, and adverse weather conditions to include wind.

2. The operator or other designated person directing the lift shall verify that the weight of load is within the static or dynamic rating for radius at which load will be lifted.

Verified weights and measured radii must take priority over RCI/RCL readings.

Attaching Load

1. Attach the hook to the load with slings, or other suitable rigging. Each hook must have a latch that is in proper working order. **Hook latches must not be wired open.**
 - a. Inspect each hook and latch before using.
 - b. Never use a hook or latch that is distorted or bent.
 - c. Make sure spring will force the latch against the tip of the hook.
 - d. Make sure the hook supports the load. The latch must never support the load. Latches are only intended to retain loose slings under slack conditions.

2. Only use slings and other rigging that are in safe operating condition and have a rating equal to or greater than the load to be lifted.
3. Do not wrap the load line around the load.
4. Use suitable protection between slings and any sharp edges on the load. When synthetic slings are used, the synthetic sling manufacturer's instructions, limitations, specifications, and recommendations must be followed.
5. Secure unused legs of a multi-leg sling before handling a load with one leg of sling.

Lifting/Moving Load

1. Before lifting or moving a load, the operator or qualified person directing the lift shall make the following checks:
 - a. Crane has a firm, uniformly supporting foundation under all crawlers. Unless otherwise specified in the Capacity Chart, the foundation must be **level to within 1%** — 0,3 m (1ft) rise or fall in 30,5 m (100 ft) distance.

When such a surface is not available, it must be provided with timbers, cribbing, or other structural members to distribute the load such that the allowable bearing capacity of the underlying member is not exceeded.
 - b. The load is secured and properly balanced in the slings or the lifting device before lifting the load more than 76 to 152 mm (3 to 6 in).
 - c. The lift and swing paths are clear of personnel and obstructions.
 - d. The load is free to be lifted.
 - e. The load line is not kinked or otherwise damaged.
 - f. Multiple part load lines are not twisted around each other in such a manner that the lines will not separate when the load is lifted.
 - g. The hook is brought over the load in a manner that will minimize twisting or swinging.
 - h. The load line and the boom hoist rope are properly spooled on the drums and seated in the sheaves.
 - i. The load drum brakes are in proper working order.

The operator shall test the load drum brakes each time a load approaching the rated load is handled. Lift the load 76 to 152 mm (3 to 6 in) and fully apply the brakes — **load must not lower through applied brakes.**
 - j. Unused load drums are parked (working and parking brakes applied; if equipped, drum pawls engaged).
- k. All personnel are clear of the swing radius of the crane's counterweight.
2. While lifting or moving the load, the operator shall take the following precautions:
 - a. Accelerate and decelerate the load smoothly to avoid excessive stress on the boom and machinery.
 - b. Avoid sudden starts and stops while swinging. Keep the swing speed under control to prevent the load from swinging out beyond the radius at which the load can be handled and to minimize the pendulum action of the load.
 - c. Sound the signal horn before swinging and intermittently while swinging, especially when approaching personnel.

If equipped, the automatic swing alarm will sound when the crane is swung.
 - d. Use taglines or other restraints to control the load when necessary.
 - e. Do not exceed any swing limitations (areas of operation) given in the Capacity Chart.
 - f. Do not allow the load, boom, or any other part of the crane to contact obstructions.
 - g. Do not use the crane to drag a load.
 - h. Do not hoist, lower, or swing the load while personnel are on the load or the hook. See Personnel Handling on [Page 26](#).
 - i. Avoid carrying the load over personnel. Loads which are suspended must be blocked or cribbed before personnel are allowed to work under or between them.
 - j. Before lifting a load which requires the use of outriggers (or anytime outriggers are used), fully extend the outrigger beams and jacks so the truck tires do not bear any load.

Securely fasten the outrigger jack pads or floats to jacks and set them on a flat, firm surface that will support the load placed on the pads or floats. Do not set the jack pads or floats in holes, on rocky ground, or on extremely soft ground.

When dictated by ground conditions, install wood blocking or steel plates under the jack pads or floats to properly distribute the loading on the supporting surface.

Wood blocking or steel plates used under the jack pads or floats must be:
 - Free of defects
 - Strong enough to prevent crushing, bending, or shear failure

- Of sufficient thickness, width, and length to completely support the jack pad or float, transmit the load to the supporting surface, and prevent shifting, toppling, or excessive settlement under load

- k. Fully retract and lock the jacks and the outrigger beams so they cannot extend when not in use.
- l. Operate with extreme caution when using two or more cranes to lift the same load.

One designated person shall be responsible for operation when two or more cranes are used to lift the same load. The designated person shall analyze the lift and instruct all personnel involved in proper rigging and positioning of the load and all movements to be made. Decisions such as the necessity to reduce crane ratings, load position, boom position, ground support, and speed of movements must be in accordance with the designated person's decision.

- m. Do not lower the load or the boom to a point where less than three full wraps of wire rope remain on the respective drum (or as otherwise indicated in local, state, or federal regulations).
 - n. Engage the boom hoist pawl when operating with the boom at a fixed radius.
 - o. Engage the luffing hoist pawl when operating with the luffing jib at a fixed radius.
3. While traveling, the operator shall take the following precautions:
- a. Sound the signal horn before traveling and intermittently while traveling, especially when approaching personnel.
If equipped, the automatic travel alarm will sound when the crane is traveled.
 - b. Carry the boom in-line with the lowerworks and facing the direction of travel.
 - c. Do not position the boom so high that it could bounce over backwards whether traveling with or without load.
 - d. Secure the rotating bed against rotation except when it is necessary to negotiate a turn, and then only when the operator is seated at controls or the boom is supported on a dolly.
 - e. Lash or otherwise restrain unused hooks so they cannot swing freely.
4. Before traveling with a load, the operator shall take the following additional precautions:

- a. A designated person shall be responsible for operation. Decisions such as the necessity to reduce crane ratings, load position, boom position, ground support, and speed of movements must be in accordance with the designated person's decision.
- b. Maintain specified tire pressures (truck cranes).
- c. Avoid sudden starts and stops. Use taglines or other restraints to control the position of the load.

Multiple Load Line Operation



WARNING

Avoid Over Load and Side Load Damage to Crane

Manitowoc highly recommends that you contact your Manitowoc dealer for lift planning assistance and approval.

Multiple load line operation is becoming common practice for applications like panel tilt-up, pile tilt-up, pile driving, rolling fabricated sections, etc. The multiple lines may be on a common shaft (each with different parts of line) or on multiple shafts (lower boom point and upper point, boom point and fixed jib point, etc).

Manitowoc authorizes multiple load line operation for those applications requiring it, provided the following steps are performed:

1. The qualified lift planner and crane operator shall read and become thoroughly familiar with the appropriate Capacity Charts and Wire Rope Specification Charts.
2. The lift planner and the crane operator shall make sure the total load does not exceed the rated capacity given in the Capacity Chart and Wire Rope Specification Chart for given boom point or jib point, whichever is less.
EXAMPLE: If one load line is lifting from the jib point, the proper jib chart applies.
3. The crane must be thoroughly inspected by a qualified person prior to setup.
4. The crane must be thoroughly inspected for load line interference caused by routing and reeving of multiple load lines. If interference is found, it must be eliminated.
5. For cranes produced before 2003, Rated Capacity Indicators/Limiters were not required by ASME B30.5 for non-personnel lifting.

To aid the operator in staying within the crane's Capacity Chart with the total applied load, Manitowoc recommends that its cranes be equipped with Rated

Capacity Indicators/Limiters to monitor the load on each load line.

Operator is still responsible for knowing load and radius whether or not the crane is equipped with load indicator(s).

6. Manitowoc recommends that each load line be equipped with an anti two-block device.
7. Manitowoc's Capacity Charts are based on freely suspended loads. To prevent side load damage to the boom, jib, and sheaves:
 - The load lines must hang as close to vertical as possible to minimize side and forward loads.
 - The distance between the load points and the hook points must be a minimum of three times the horizontal distance between the hook point on the load being lifted
 - The load must remain centered on the boom and jib point shafts unless special lift approval is granted by Manitowoc
 - The load lines should be located over the load's center of gravity as it is supported on a trailer, a barge, or the ground.
8. The crane operator shall be familiar with the operational characteristic of the crane as it relates to multiple drum operation (simultaneous operation, same or opposite direction, or individual operation).
9. When using tandem drums, the maximum operating layers may be limited depending on whether the crane was initially designed for tandem drum operation or not.
10. Load shift when lifting with two hooks may be more unpredictable than typical one hook lifting.

Holding Load

When a load is suspended, the operator shall take the following precautions:

1. Not leave his/her position at the controls
2. Not allow personnel to stand or pass under the load
3. Move all controls to off, apply all drum brakes, engage the boom hoist pawl, and apply the swing and travel brakes or locks.

SIGNALS

1. Continuous communication must be maintained between the operator and the signal person during all crane movements. If communication is disrupted, ***operator shall stop all crane movements.***
2. Signals to the operator shall be in accordance with the standard signals shown in Section 3, unless communications equipment (telephone, radio, etc.) is used.
3. All signals must be easily understood by the operator at all times. The operator shall not respond to any signal which is not clearly understood.
4. For operations not covered in the standard signals, or for special situations or emergencies, additional signals may be required. In those cases, the signals used must be agreed upon in advance by the operator and the signal person. The signals used must not conflict with or have potential to be confused with the standard signals.
5. When it is necessary to give instructions to the operator (other than those established by the signal system), all crane motions must be stopped.
6. The signal person shall:
 - a. Be tested by a designated person and show that he or she has a basic understanding of crane operations and limitations, to include boom deflection.
 - b. Be thoroughly familiar with the standard hand signals and voice signals if used.
 - c. Be positioned in clear view of the operator. The signal person's position should give him or her a clear view of the load, the crane, and the operating area.
 - d. Direct the load so it does not pass over personnel.
 - e. Keep unnecessary personnel out of the crane's operating area.
7. When moving the crane, the following audible signals must be used:
 - a. STOP - one short audible signal
 - b. GO AHEAD - two short audible signals
 - c. BACK UP - three short audible signals

SAFETY DEVICES



WARNING

Do not operate the crane unless all safety devices listed in this section are in proper working order.

- If a safety device stops working properly during operation, the operator shall safely stop operation.
- If any safety device listed in this section is not in proper working order, the safety device must be taken out of service and crane operation must not resume until the safety device is again working properly.
- Alternative measures are not permitted to be used for a faulty safety device.
- Always tag-out any faulty safety device and place a warning tag in the cab stating that the crane is out of service and must not be used.

Manitowoc provides the following safety devices on its cranes.

1. Horn activated by a switch on the control console in the operator cab
If the horn is not working properly, it must be tagged-out or removed if possible.
2. Crane level indicator: either electronic (viewable in crane's electronic display) or mechanical (viewable from operator cab seat). If the crane level indicator is not working properly, it must be tagged-out or removed, if possible.
3. Cranes operating on a barge require: a trim indicator, a swing brake, and a wind direction indicator if the wind is a factor (supplied by crane owner or user).
4. Boom stops, both physical and automatic
If a boom stop is damaged or not working properly, it must be tagged-out or removed if possible.
5. Jib stops, both physical and automatic (for fixed jib and luffing jib)
If a jib stop is damaged or not working properly, it must be tagged-out or removed if possible.
6. Pedal locks for all foot-operated brakes (if applicable)
If a pedal lock is damaged or not working properly, it must be tagged-out or removed if possible.
7. An integral holding device or check valve on each jacking cylinder.

OPERATIONAL AIDS



WARNING

Do not operate the crane unless all applicable operational aids listed in this section are in proper working order, except:

- Where an operational aid is being repaired
- The crane user implements a specified temporary alternative measure

If an operational aid stops working properly during operation, the operator shall safely stop operation until the temporary alternative measures are implemented or the device is again working properly.

Manitowoc provides the following operational aids on its cranes, either as standard equipment or optional equipment. The operational aids are designated as Category 1 or Category 2:

Category 1 Operational Aids

If a Category 1 operational aid is not working properly, it must be repaired no later than 7 calendar days after the deficiency occurs.

Exception: If the crane user documents that he/she has ordered the necessary parts within 7 calendar days of the occurrence of the deficiency, the repair must be completed within 7 calendar days of receiving the parts.

1. Boom or Luffing Jib Angle Limiter (automatic boom or jib stop)

Temporary alternative measures if inoperative or malfunctioning:

The qualified person directing the lift shall make sure the maximum boom or jib angle/radius specified in the Capacity Chart for the load being handled is not exceeded. One or more of the following methods must be used:

- a. Measure radius using a tape measure.
- b. Measure the boom angle with a protractor-level on the centerline of boom.
- c. Clearly mark the boom or luffing hoist cable (so it can easily be seen by the operator) at a point that gives the operator sufficient time to stop the boom or jib within the minimum allowable radius.

In addition, install mirrors or remote video cameras and displays if necessary for the operator to see the mark.

- d. Clearly mark the boom or luffing hoist cable (so it can easily be seen by a designated signal person)

at a point that gives the signal person sufficient time to signal the operator and have the operator stop the boom or jib within the minimum allowable radius.

2. Anti-Two-Block Device

Temporary alternative measures if inoperative or malfunctioning:

The qualified person directing the lift shall establish procedures to furnish equivalent protection. One or more of the following methods must be used:

- a. Assign a signal person to signal the operator to stop hoisting when the load is a safe distance from the boom or jib point.
- b. Clearly mark the hoist cable (so it can easily be seen by the operator) at a point that will give the operator sufficient time to stop the load a safe distance from the boom or jib point.

The temporary alternative measures for the anti-two-block device do not apply when lifting personnel in load line supported baskets. ***Personnel shall not be lifted in load line supported baskets when anti-two-block devices are not functioning properly.***

Category 2 Operational Aids

If a Category 2 operational aid is not working properly, it must be repaired no later than 30 calendar days after the deficiency occurs.

Exception: If the employer documents that they have ordered the necessary parts within 7 calendar days of the occurrence of the deficiency, and the part is not received in time to complete the repair in 30 calendar days, the repair must be completed within 7 calendar days of receiving the parts.

1. Rated Capacity Indicator/Limiter

Temporary alternative measures if inoperative or malfunctioning:

The qualified person directing the lift shall establish procedures for determining load weights and shall make sure that the weight of the load does not exceed the crane's rating at the radius where the load is handled.

The weight of the load must be provided to the operator before the lift is made.

2. Boom Angle or Radius Indicator

Temporary alternative measures if inoperative or malfunctioning:

- a. Refer to the pendulum boom angle indicator on the boom butt (visible from operator cab).
- b. Measure the boom angle with a protractor-level on the centerline of boom.
- c. Measure radius using a tape measure.

3. Jib Angle or Radius Indicator

Temporary alternative measures if inoperative or malfunctioning. Use either or both:

- a. First, make sure you know the boom angle (see item 2 above).
- b. Then, measure radius using a tape measure.

4. Drum Rotation Indicator

Temporary alternative measures if inoperative or malfunctioning:

Mark the drum to indicate its rotation.

If the operator cannot see the drum, add mirrors or remote video cameras and displays so the operator can see the mark.

5. OPTIONAL Swing Limiter or Proximity Device

Temporary alternative measures if inoperative or malfunctioning:

The qualified person directing the lift shall establish procedures to furnish equivalent protection (for example, assign an additional signal person to observe the distance between the boom or load and job site obstructions to include power lines or to limit the swing sector specified in the Capacity Chart).

6. OPTIONAL Drum Spooling Limiter (maximum or minimum bail limit)

Temporary alternative measures if inoperative or malfunctioning:

The qualified person directing the lift or a designated signal person shall watch the drum and signal the operator to stop it before it is over spooled (rope does not jump off drum) or before there are less than 3 full wraps of wire rope on the load drum or boom hoist.

7. OPTIONAL Closed-Circuit Television (CCTV)

Temporary alternative measures if inoperative or malfunctioning:

A designated signal person shall watch the load, the drums, and the counterweight and provide necessary hand or voice signals to the crane operator.

ASSEMBLING, DISASSEMBLING, OR OPERATING CRANE NEAR ELECTRIC POWER AND TRANSMISSION LINES

Electrocution Hazard

Thoroughly read, understand, and abide by all applicable federal, state, and local regulations regarding operation of cranes near electric power lines or equipment.

United States federal law prohibits the use of cranes closer than 6 m (20 ft) to power sources up to 350 kV and greater distances for higher voltages unless the line's voltage is known [29CFR1910.180 and 29CFR1926.1400].

To avoid death or serious injury, Manitowoc recommends that all parts of the crane, boom, and load be kept at least 6 m (20 ft) away from all electrical power lines and equipment less than 350 kV.

NOTE For detailed guidelines on operating near power lines, refer to the current edition of OSHA 29CFR1926.1400 and ASME B30.5 American National Standard.



WARNING

Electrocution Hazard!

Manitowoc cranes are not equipped with all features required to operate within OSHA 29CFR1926.1408, Table A clearances when the power lines are energized.

1. Keep all personnel and their personal belongings (clothing, water coolers, lunch boxes, etc.) away from the crane if it is being operated near electrical power lines or equipment.
2. Before operating the crane in the vicinity of electrical power lines or equipment, notify the power utility company. Obtain positive and absolute assurance that the power has been turned off.

The crane is NOT INSULATED. Always consider all parts of the load and the crane as conductors, including the wire rope, pendants or straps, and taglines.

Most overhead power lines ARE NOT insulated. Treat all overhead power lines as being energized unless you have reliable information to the contrary from the utility company or owner.

The rules in this section must be followed at all times, even if the electrical power lines or equipment have been de-energized.

3. Crane operation is dangerous when close to an energized electrical power source. Exercise extreme

caution and prudent judgment. Operate slowly and cautiously when in the vicinity of power lines.

4. If the load, wire rope, boom, or any portion of the crane contacts or comes too close to an electrical power source, everyone in, on, and around the crane can be seriously injured or killed.

The safest way to avoid electrocution is to stay away from electrical power lines and electrical power sources.

5. The operator is responsible for alerting all personnel to the dangers associated with electrical power lines and equipment. The crane is not insulated. Do not allow unnecessary personnel in the vicinity of the crane while operating. Permit no one to lean against or touch the crane. Permit no one, including riggers and load handlers, to hold the load, load lines, taglines, or rigging gear.
6. Even if the crane operator is not affected by an electrical contact, others in the area may become seriously injured or killed.
7. It is not always necessary to contact a power line or power source to become electrocuted. Electricity, depending on magnitude, can arc or jump to any part of the load, load line, or crane boom if it comes too close to an electrical power source. Low voltages can also be dangerous.

Set-Up and Operation

1. During crane use, assume that every line is energized ("hot" or "live") and take necessary precautions.
2. Position the crane such that the load, boom, or any part of the crane and its attachments cannot be moved to within 6 m (20 ft) of electrical power lines or equipment. This includes the crane boom and all attachments. Overhead lines tend to blow in the wind, so allow for movement of the overhead lines when determining a safe operating distance.
3. Erect a suitable barricade to physically restrain the crane, all attachments, and the load from entering into an unsafe distance from electrical power lines or equipment.
4. Plan ahead and always plan a safe route before traveling under power lines. A wooden clearance frame should be constructed to ensure sufficient clearance is maintained between crane and power lines.
5. Appoint a reliable and qualified signal person, equipped with a loud signal whistle or horn and voice communication equipment, to warn the operator when any part of the crane or load moves near a power source. This person should have no other duties while the crane is working.

6. Taglines should always be made of non-conductive materials. Any tagline that is wet or dirty can conduct electricity.
7. DO NOT store materials under power lines or close to electrical power sources.
8. When operating near transmitter/communication towers where an electrical charge can be induced into the crane or load:
 - The transmitter must be deenergized OR,
 - Tests must be made to determine if an electrical charge will be induced into the crane or load
 - The crane must be provided an electrical ground
 - If taglines are used, they must be non-conductive
 - Every precaution must be taken to dissipate induced voltages. Consult with a qualified RF (radio frequency) Consultant. Also refer to local, state, and federal codes and regulations
6. Proximity sensing and warning devices are available in different types. Some use boom point (localized) sensors and others use full boom length sensors. No warning may be given for components, cables, loads, and other attachments located outside of the sensing area. Reliance is placed upon the operator in selecting and properly setting the sensitivity of these devices.
7. Never rely solely on a device to protect you and your fellow workers from danger.

Some variables you shall know and understand are:

 - Proximity devices are advertised to detect the existence of electricity and not its distance, quantity, or magnitude.
 - Some proximity devices may detect only alternating current (AC) and not direct current (DC).
 - Some proximity devices detect radio frequency (RF) energy and others do not.
 - Most proximity devices simply provide a signal (audible, visual, or both) for the operator and this signal must not be ignored.
 - Sometimes the sensing portion of the proximity devices becomes confused by complex or differing arrays of power lines and power sources.

Electrocution Hazard Devices

1. The use of insulated links, insulated boom cages/guards, proximity warning devices, or mechanical limit stops does not ensure that electrical contact will not occur. Even if codes or regulations require the use of such devices, failure to follow the rules in this section may result in serious injury or death.
2. Be aware that such devices have limitations and you should follow the rules and precautions outlined in this section at all times even if the crane is equipped with these devices.
3. Insulating links installed into the load line afford limited protection from electrocution hazards. Links are limited in their lifting abilities, insulating properties, and other properties that affect their performance. Moisture, dust, dirt, oils, and other contaminants can cause a link to conduct electricity. Due to their capacity ratings, some links are not effective for large cranes and/or high voltages/currents.
4. The only protection that may be afforded by an insulated link is below the link (electrically downstream), provided the link has been kept clean, free of contamination, has not been scratched or damaged, and is periodically tested (just before use) for its dielectric integrity.
5. Boom cages and boom guards afford limited protection from electrocution hazards. They are designed to cover only the boom nose and a small portion of the boom. Performance of boom cages and boom guards is limited by their physical size, insulating characteristics, and operating environment (for example, dust, dirt, moisture, etc.). The insulating characteristics of these devices can be compromised if not kept clean, free of contamination, and undamaged.

8. DO NOT depend on grounding. Grounding of a crane affords little or no protection from electrical hazards. The effectiveness of grounding is limited by the size of the (wire) conductor used, the condition of the ground, the magnitude of the voltage and current present, and numerous other factors.

Electrical Contact

If the crane comes in contact with an energized power source, the operator shall:

1. Stay in the crane cab. DON'T PANIC.
2. Immediately warn PERSONNEL in the vicinity to STAY AWAY.
3. Attempt to move the crane away from the contacted power source using the crane's controls which are likely to remain functional.
4. Stay in the crane until the power company has been contacted and the power source has been de-energized. NO ONE shall attempt to come close to the crane or load until the power has been turned off.

Only as a last resort should an operator attempt to leave the crane upon contacting a power source. If it is absolutely necessary to leave the cab, JUMP COMPLETELY CLEAR OF CRANE. DO NOT STEP OFF. Hop away with both feet together. DO NOT walk or run.

- Following any contact with an energized electrical source, your Manitowoc dealer shall be immediately advised of the incident and consulted on necessary inspections and repairs.

If the dealer is not immediately available, contact the Manitowoc Crane Care Lattice Team. The crane must not be returned to service until it is thoroughly inspected for any evidence of damage and all damaged parts are repaired or replaced as authorized by Manitowoc or your Manitowoc dealer.

REFUELING

- When using a portable container to refuel the crane, the container must be a safety-type can equipped with an automatic closing cap and a flame arrester.
- The engine must be **stopped** before refueling the crane.
- Smoking and open flames must be prohibited in refueling area.

FIRE EXTINGUISHERS

- A portable fire extinguisher with a minimum rating of 10 BC must be installed in operator's or machinery cab of the crane.
- The operator and all maintenance personnel shall be thoroughly familiar with the location, use, and care of the fire extinguisher(s) provided.

ACCIDENTS

If this crane becomes involved in a property damage and/or personal injury accident, immediately contact your Manitowoc dealer or the Product Safety and Reliability Department at the following address:

Manitowoc Cranes
2401 So. 30th St.
Manitowoc, WI 54220
Phone: 920-684-6621

Provide a complete description of the accident, including the crane model and serial number.

The crane must not be returned to service until it is thoroughly inspected for any evidence of damage. All damaged parts must be repaired or replaced as authorized by Manitowoc.

SAFE MAINTENANCE



WARNING

Importance of safe maintenance cannot be over emphasized. Carelessness and neglect on part of maintenance personnel can result in their death or injury and costly damage to the crane or property.

Safety information in this publication is intended only as a guide to assist qualified maintenance personnel in safe maintenance. Manitowoc cannot foresee all hazards that will arise in field; therefore, **safety remains responsibility of maintenance personnel and crane owner.**

Maintenance Instructions

To ensure safe and proper operation of Manitowoc cranes, they must be maintained according to the instructions contained in this manual and in the Service Manual provided with the crane.

Crane maintenance and repair must be performed by qualified personnel. These personnel shall **read Operator Manual and Service Manual before attempting any maintenance procedure.** If there is any question regarding maintenance procedures or specifications, contact your Manitowoc dealer for assistance.

Qualified person is defined as one who by reason of training and experience is thoroughly familiar with the crane's operation and required maintenance as well as the hazards involved in performing these tasks.

Training and qualification of maintenance and repair personnel are crane owner's responsibility.

Safe Maintenance Practices

- Perform the following steps (as applicable) before starting a maintenance procedure:
 - Park the crane where it will not interfere with other equipment or operations.
 - Lower all loads to the ground or otherwise secure them against movement.
 - Lower the boom onto blocking at ground level, if possible, or otherwise secure the boom against dropping.
 - Move all controls to off and secure all functions against movement by applying or engaging all brakes, pawls, or other locking devices.
 - Stop the engine and render the starting means inoperative.

- f. Place a warning sign at the start controls alerting other personnel that the crane is being serviced and the engine must not be started. **Do not remove sign until it is safe to return the crane to service.**
2. Do not attempt to maintain or repair any part of the crane while the engine is running, unless absolutely necessary.
If the engine must be run, keep your clothing and all parts of your body away from moving parts. **Maintain constant verbal communication between person at controls and person performing maintenance or repair procedure.**
 3. Wear clothing that is relatively tight and belted.
 4. Wear appropriate eye protection and approved hard hat.
 5. Never climb onto or off a moving crane. **Climb onto and off the crane only when it is parked and only with operator's permission.**
Use *both hands* and handrails, steps and ladders provided to climb onto and off the crane.
Lift tools and other equipment which cannot be carried in pockets or tool belts onto and off the crane with hand lines or hoists.
 6. The boom and gantry are not intended as ladders. Do not attempt to climb lattice work of the boom or gantry to get to maintenance points. If the boom or gantry is not equipped with an approved ladder, lower them before performing maintenance or repair procedures.
 7. Do not remove cylinders until the working unit has been securely restrained against movement.
 8. Pinch points are impossible to eliminate; watch for them closely.
 9. Pressurized air, coolant, and hydraulic oil can cause serious injury. Make sure all air, coolant, and hydraulic lines, fittings, and components are tight and serviceable.
Do not use your hands to check for air, coolant or hydraulic oil leaks:
 - Use a soap and water solution to check for air leaks (apply to fittings and lines and watch for bubbles).
 - Use a piece of cardboard or wood to check for coolant and hydraulic oil leaks.
 10. Relieve pressure before disconnecting air, coolant, and hydraulic lines and fittings.
 11. Do not remove the radiator cap while the coolant is hot or under pressure. Stop the engine, wait until the pressure drops and the coolant cools, then slowly remove the cap.
 12. Avoid battery explosion: do not smoke while performing battery maintenance or short across battery terminals to check its charge.
 13. Read the safety information in the battery manufacturer's instructions before attempting to charge a battery.
 14. Avoid battery acid contact with skin and eyes. If contact occurs, flush the area with water and immediately consult a doctor.
 15. Stop the engine before refueling the crane.
 16. Do not smoke or allow open flames in refueling area.
 17. Use a safety-type can with an automatic closing cap and flame arrestor for refueling.
 18. Hydraulic oil can also be flammable. Do not smoke or allow open flames in the area when filling hydraulic tanks.
 19. Never handle wire rope with bare hands. Always wear heavy-duty gloves to prevent being cut by broken wires.
 20. Use extreme care when handling coiled pendants. Stored energy can cause the coiled pendants to uncoil quickly with considerable force.
 21. When inflating tires, use a tire cage, a clip-on inflator, and an extension hose which permits standing well away from the tire.
 22. Only use cleaning solvents which are non-volatile and non-flammable.
 23. Do not attempt to lift heavy components by hand. Use a hoist, jacks, or blocking to lift components.
 24. Use care while welding or burning on the crane. Cover all hoses and components with non-flammable shields or blankets to prevent a fire or other damage.
 25. To prevent damage to crane parts (bearings, cylinders, swivels, slewing ring, computers, etc.), perform the following steps **before welding on the crane:**
 - Disconnect all cables from batteries
 - Disconnect output cables at engine junction box
 - Attach the ground cable from the welder directly to the part being welded and as close to the weld as possible

Do not weld on the engine or engine mounted parts (per engine manufacturer).
 26. Disconnect and lock the power supply switch before attempting to service high voltage electrical components and before entering tight areas (such as carbody openings) containing high voltage components.
 27. When assembling and disassembling booms, jibs, or masts on the ground (with or without support of boom

rigging pendants or straps), securely block each section to provide adequate support and alignment.

Do not go under boom, jib, or mast sections while connecting bolts or pins are being removed.

28. Unless authorized in writing by Manitowoc, do not alter the crane in any way that affects the crane's performance (including welding, cutting, or burning of structural members or changing pressures and flows of air/hydraulic components). Doing so will invalidate all warranties and Capacity Charts and make the crane owner/user liable for any resultant accidents.
29. **Keep crane clean.** Accumulations of dirt, grease, oil, rags, paper, and other waste will not only interfere with safe operation and maintenance but also create a fire hazard.
30. Store tools, oil cans, spare parts, and other necessary equipment in tool boxes. Do not allow these items to lie around loose in the operator cab or on walkways and stairs.
31. Do not store flammable materials on the crane.
32. Do not return the crane to service at completion of maintenance or repair procedures until all guards and covers have been reinstalled, trapped air has been bled from hydraulic systems, safety devices have been

reactivated, and all maintenance equipment has been removed.

33. Perform a function check to ensure proper operation at the completion of maintenance or repair.

ENVIRONMENTAL PROTECTION

Dispose of waste properly! Improperly disposing of waste can threaten the environment.

Potentially harmful waste used in Manitowoc cranes includes — but is not limited to — oil, fuel, grease, coolant, air conditioning refrigerant, filters, batteries, and cloths which have come into contact with these environmentally harmful substances.

Handle and dispose of waste according to local, state, and federal environmental regulations.

When filling and draining crane components: do not pour waste fluids onto the ground, down any drain, or into any source of water.

- Always drain waste fluids into leak proof containers that are clearly marked with what they contain
- Always fill or add fluids with a funnel or a filling pump
- Immediately wipe up any spills

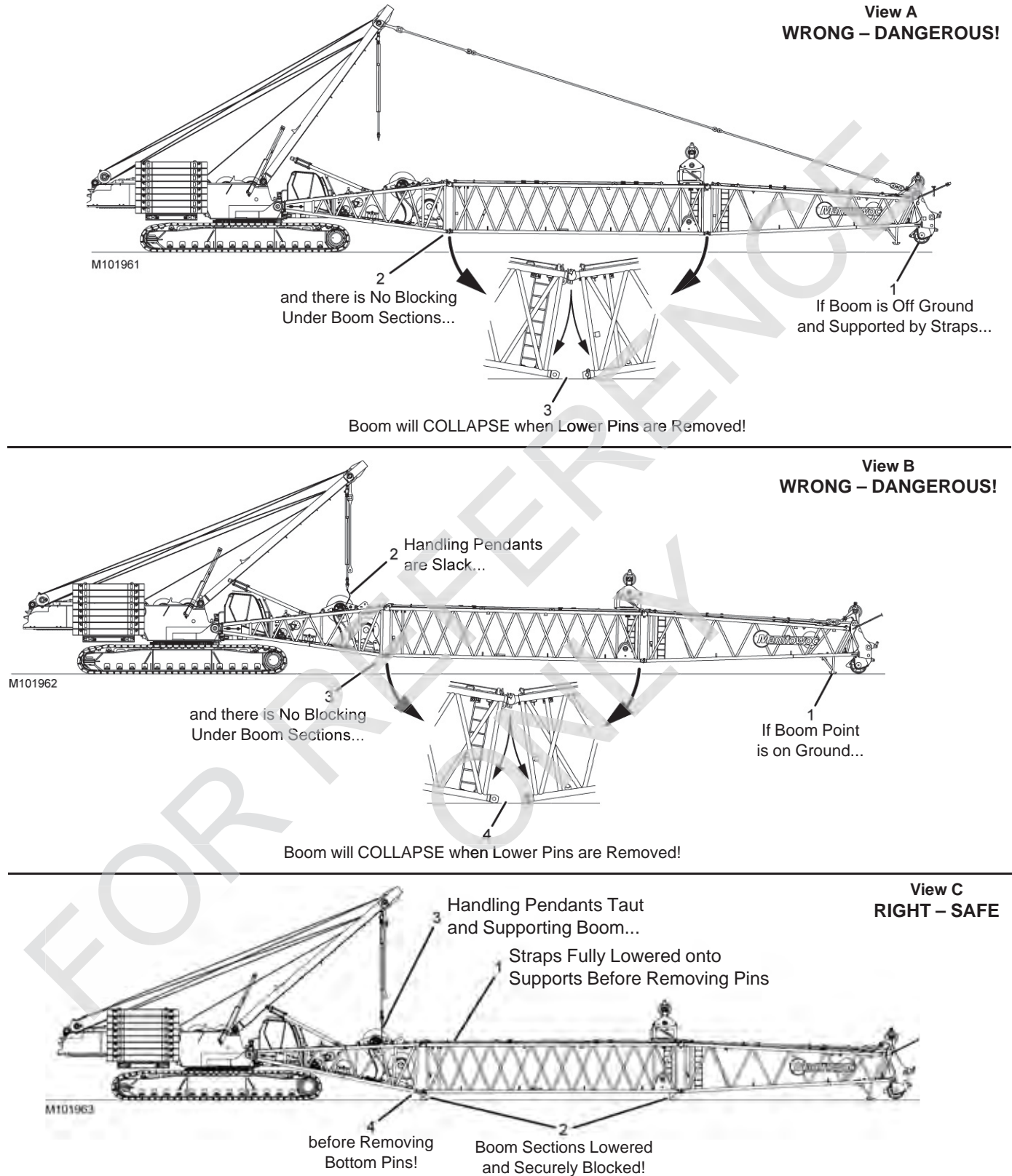

Figure 2-4. Boom Disassembly

BOOM DISASSEMBLY SAFETY

NOTE The term “boom” used in the following instructions applies to all lattice attachments (fixed jib, luffing jib, mast, etc.).



DANGER!

Collapsing Boom Hazard!

Prevent death or serious injury when disassembling boom sections — read and adhere to the following instructions.

Safe handling of lattice booms during disassembly is a primary concern for preventing serious or fatal injuries. A boom can collapse during disassembly if workers fail to observe safe working practices.

Accidents during boom disassembly usually result from one of three primary causes:

- Workers are not familiar with equipment or are not properly trained
- Disassembly area is not suitable
- Safe procedures are overlooked because not enough time is allocated for the task

General

Safety decals (Figure 2-5) are placed near the connectors on the boom sections as shown on the Boom Disassembly Decal Drawing at the end of this section.

Workers involved with boom disassembly shall be trained and experienced in the operation and disassembly of construction cranes. Everyone shall read and understand these instructions, the information in the Boom Assembly Drawing, and the instructions in Section 4 before beginning disassembly. **Anyone who has a question should ask for an explanation. One worker who does not fully understand or fails to follow correct procedures can endanger other workers.**

Location

Select a suitable location for boom disassembly. It must be firm, level, and free of obstructions. It should have enough open space to accommodate the crane, the length of boom, and – if required – movement of an assist crane or other equipment. If possible, secure the area to keep unauthorized personnel and vehicles away.

Pin Removal

When removing pins from boom sections, stand clear of pins being removed. Even though the boom is resting on

blocking, individual pin connections may still be under load. Pins can be ejected forcefully if the boom has any pressure on it or if the boom is not supported properly.

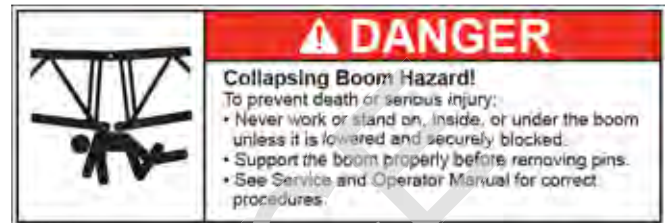

M101904

Figure 2-5. Safety Decal

Disassembly Precaution

Always block boom sections so they are securely supported and cannot shift or move suddenly when pins are removed. If there is any doubt about a boom disassembly procedure, **block tightly under boom sections before removing any pin.**



DANGER

Collapsing Boom Hazard!

Boom can collapse or jerk when pins are removed. To avoid death or serious injury:

- Do not remove bottom connecting pins from any boom section when boom is supported by straps as shown in Figure 2-4, View A.
- Do not remove strap connecting pins until straps are fully lowered into supports as shown in Figure 2-4, View C.
- Do not remove bottom connecting pins from any boom section when boom point is resting on ground and handling pendants are slack as shown in Figure 2-4, View B.
- Never work or stand inside boom unless it is lowered and securely blocked as shown in Figure 2-4, View C.
- Do not stand or walk on top of the boom unless it has walkways.



DANGER

Falling Boom Hazard!

Crane can tip or the boom can collapse if excess boom is cantilevered. Never cantilever more boom than allowed in rigging drawings or capacity charts.

PERSONNEL HANDLING POLICY

In 1998, the American Society of Mechanical Engineers issued a new American National Standard entitled, Personnel Lifting Systems, ASME B30.23-1998. This standard provides, ***“lifting and lowering of personnel using ASME B30 Standard hoisting equipment shall be undertaken only in circumstances when it is not possible to accomplish the task by less hazardous means. Unless all of the applicable requirements of this volume are met, the lifting or lowering of personnel using ASME B30 Standard equipment is prohibited.”***

The ASME Standards recognize that mobile and locomotive cranes are primarily designed and intended for handling materials and not personnel. The ASME Standards have a retrofit statement that applies to existing cranes after the standards go into effect. It is not the intent of the standards to require retrofitting of existing equipment. If an item is being modified, the performance requirement must be reviewed relative to the current standard.

This new standard is consistent with the U.S. Department of Labor, Occupational Safety and Health Administration (OSHA) regulations for Construction that state, in 29CFR1926.1431(a): ***The use of a crane or derrick to hoist employees on a personnel platform is prohibited, except when the erection, use, and dismantling of conventional means of reaching the work site, such as a personnel hoist, ladder, aerial lift, elevating work platform or scaffold, would be more hazardous or is not possible because of structural design or work site conditions.***

Use of a Manitowoc crane to handle personnel is acceptable provided:

- The crane user shall comply with the manufacturer's specifications and limitations for lifting accessories (hooks, slings, personnel platforms, etc.).
- The requirements of the applicable national, state and local regulations and safety codes are met.
- A determination has been made that use of a crane to handle personnel is the least hazardous means to perform the work.
- The crane operator shall be qualified to operate the specific type of hoisting equipment used in the personnel lift.
- The crane operator shall remain in the crane cab at all times when personnel are off the ground.
- The crane operator and occupants have been instructed in the recognized hazards of personnel platform lifts.
- The crane is in proper working order.
- Load and boom hoist drum brakes, swing brakes, and locking devices such as pawls and dogs must be

engaged when the occupied personnel platform is in a stationary position.

- The crane must be equipped with a boom angle indicator that is visible to the crane operator.
- The crane must be equipped with boom hoist limiting device.
- If the luffing jib is used for hoisting personnel, the crane must be equipped with a luffing jib angle indicator that is visible to the crane operator.
- If the luffing jib is used for hoisting personnel, the crane must be equipped with a luffing hoist limiting device.
- The crane is equipped with a positive acting device which prevents contact between the load block or overhaul ball and the boom tip (anti-two-block device).

For friction cranes, this implies the addition of spring applied brakes activated by the anti-two-block device. The load line hoist drum must have a system or device on the power train, other than the load hoist brake, which regulates the lowering rate of speed of the hoist mechanism (controlled load lowering).

Free fall of the hoist line is prohibited.

- The Operator Manual is in the cab, readily accessible to the operator.
 - The crane's load Capacity Chart is affixed inside the crane cab, readily accessible to the operator. The total weight of the loaded personnel platform and related rigging must not exceed 50 percent of the rated capacity for the radius and configuration of the crane.
 - The crane is uniformly level within one percent of level grade and located on a firm footing. Some Capacity Charts require more stringent levelness criteria.
- Cranes with outriggers or stabilizers must have them all extended and locked. All outriggers or stabilizers must be extended equally in accordance with the Capacity Charts and operating procedures.
- Handling personnel from a platform suspended by wire rope from a luffing jib is acceptable, but only when it is not possible to accomplish the task using a less hazardous means. The crane user and operator shall take into account hazards that may be present when using a luffing jib.
 - Direct attachment of a personnel platform to a luffing jib is prohibited.
 - The platform meets the requirements as prescribed by applicable standards and regulations.
 - Applicable personal protection equipment is provided (for example, personal fall-protection system).

- For wire rope suspended platforms, the crane is equipped with a hook latch that can be closed and locked, eliminating the throat opening.
- The platform is properly attached and secure.
- Personnel platforms must not be used in winds exceeding 20 mph (9 m/s) at the hoisted platform height or in electric storms, snow, ice, sleet, or other adverse weather conditions which could affect the safety of personnel.
- Hoisting personnel within 6 m (20 ft) of a power line that is up to 350 kV or within 15 m (50 ft) of a power line that is over 350 kV is PROHIBITED, except for work covered in OSHA 29CFR1926 subpart V.

For operation outside the United States, the requirements of the applicable national, state and local regulations and safety codes must be met. This may include, in addition to the above:

- Automatic brakes such that when the equipment operating controls are released, the motions are brought to rest
- A holding device (such as a load hold check valve) must be provided in the hydraulic or pneumatic systems to prevent uncontrolled movement of the hoisting equipment in the case of a system failure

Manitowoc offers upgrade packages for friction controlled models to install anti-two-block, dead man control, and automatic hoist system control requirements to satisfy other codes and standards.

Manitowoc recommends that cranes be properly maintained, regularly inspected, and repaired as necessary. All safety signs must be in place and legible. We also urge Manitowoc crane owners to upgrade their cranes with rated capacity indicator/limiter systems for all lifting operations.

If you have any questions about this subject or other product safety matters relating to the operation and use of a Manitowoc crane, please contact your Manitowoc dealer or the Product Safety and Reliability Department at the following address:

Manitowoc Cranes
2401 So. 30th St.
Manitowoc, WI 54220
Phone:920-684-6621

PEDESTAL/BARGE MOUNTED CRANES



WARNING **Overload Hazard!**

A pedestal mounted crane will not tip to indicate to the operator that the crane's capacity has been exceeded. When the capacity of a pedestal mounted crane is exceeded, the hook rollers or other structural components may break, before the load lines fail, causing the crane to separate from the pedestal.

For this reason, great care must be taken to operate a pedestal mounted crane within its rated capacity.

Careful planning is required before a crane can be operated on a barge. The crane user shall verify that the barge is capable of limiting crane list and/or dynamics to the maximum allowable specified in the Capacity Charts. If the specified crane list and/or dynamic conditions are exceeded, the crane's capacity may be exceeded; the hook rollers or other structural components may break, causing the crane to separate from the pedestal.



WARNING

The crane owner/user shall verify that the method used to fasten or restrain the crane to the foundation, the barge, the ship or the floating platform is strong enough, under all operating conditions, to prevent the crane from breaking off the foundation or moving on the barge.

Manitowoc does not permit use of a truck crane on a barge, a ship or a floating platform.

Pedestal Mounted Crane

Also see ASME publication B30.8-2004, Floating Cranes and Derricks.

Definition

A pedestal mounted crane is a crane which is securely fastened to a foundation, barge, ship, or floating platform so the crane is restrained from tipping.

Examples

1. Crane rotating bed mounted on a turret (pedestal) which is securely fastened to the foundation (Figure 2-6).

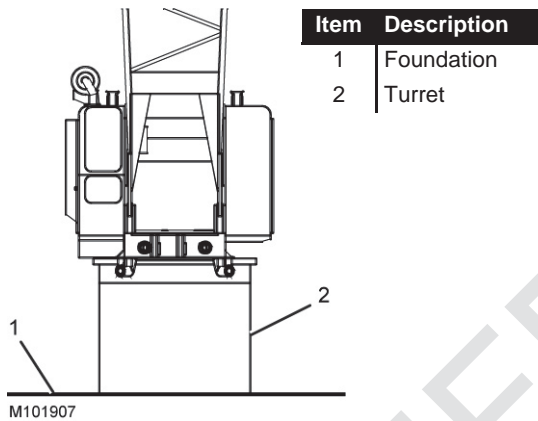

Figure 2-6. Turret-Mounted Crane

2. Crane rotating bed mounted on a carbody (crawlers removed) which is securely fastened to the foundation (Figure 2-7).

NOTE If the carbody will be bolted to the foundation, contact your Manitowoc dealer for the recommended bolt pattern and for the type and quantity of bolts to be used.

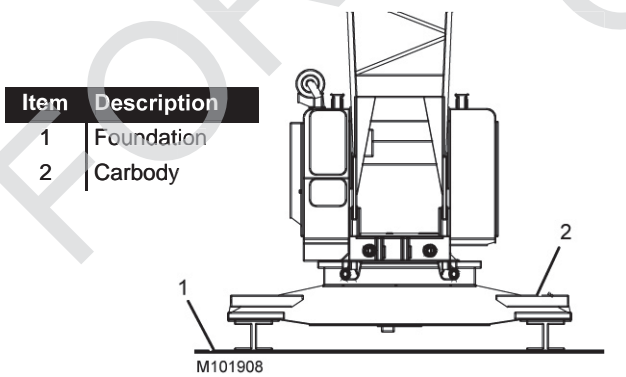

Figure 2-7. Carbody-Mounted Crane

Barge Mounted Crane

Definition

A barge mounted crane is a crane that is anchored or restrained in a work area of the barge, ship, or floating platform and is subjected to tipping forces.

Examples

NOTE The foundation is the deck of the barge, ship, or floating platform.

1. Crawler-mounted crane with the carbody anchored with tie-downs to the foundation (Figure 2-8).

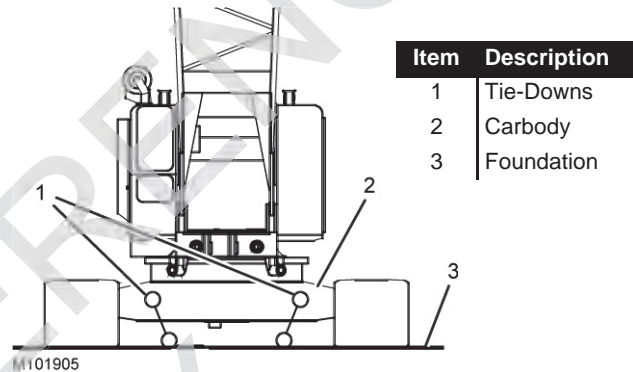

Figure 2-8. Crawler-Mounted Crane

2. Crawler-mounted crane working on a timbered area of the barge, ship, or floating platform with the crawlers restrained by curbing and end stops (Figure 2-9). When not working, the crane carbody is anchored with tie-downs to the foundation. **Traveling with load is not permitted.**

NOTE Manitowoc does not permit traveling on a barge deck with load.

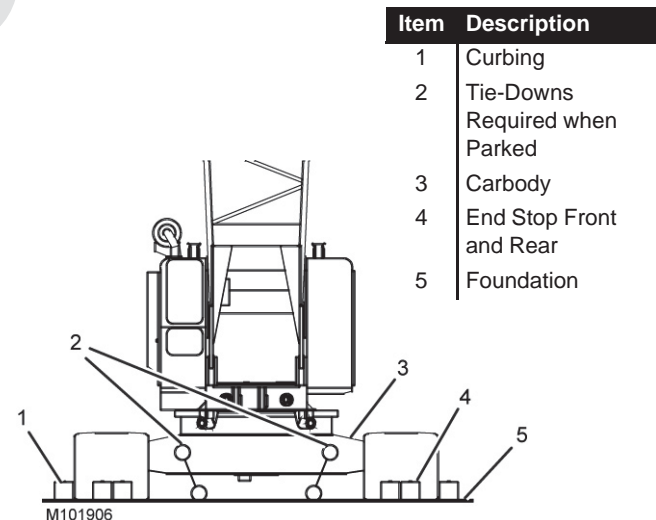

Figure 2-9. Crawler-Mounted Crane

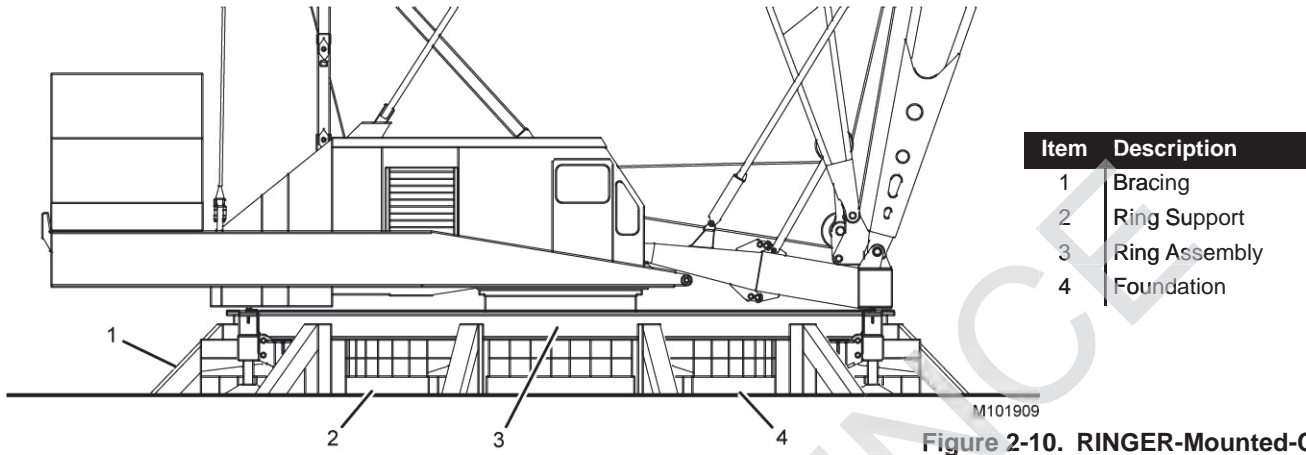
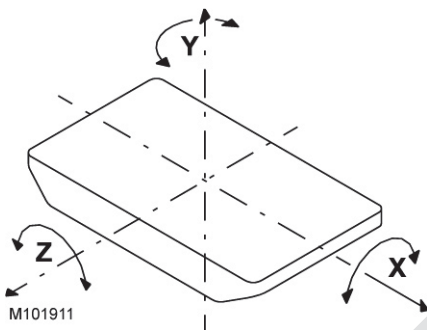

Figure 2-10. RINGER-Mounted-Crane



AXIS		TRANSITIONAL		ROTATIONAL	
SYMBOL	NAME	STATIC	DYNAMIC	STATIC	DYNAMIC
X	Longitudinal		Surge	Heel List	Roll
Y	Vertical		Heave		Yaw
Z	Lateral		Sway	Trim	Pitch

Figure 2-11. Barge Dynamics

3. RINGER® (crawler mounted, carbody mounted) supported on blocking, screw jacks, or steel pedestals which are braced and fastened to the foundation in such a manner as to prevent movement (Figure 2-10).

NOTE RINGERS must be equipped with hook rollers on the boom carrier and the counterweight carrier.

4. RINGER (platform mounted) which has the ring braced and fastened directly to the foundation in such a manner as to prevent movement.

Capacity Charts for Barge Mounted Crane

Manitowoc provides two types of Capacity Charts for a crane mounted on a barge or other supporting structure under static conditions.

1. A Capacity Chart based on tipping when the crane is anchored only to prevent shifting.
2. A Capacity Chart based on structural competence when the crane is securely fastened for use as a pedestal mounted crane.

NOTE Unless otherwise specified in a machine list Capacity Chart, a 0 degree machine list Capacity Chart rating applies to machine list **not to exceed 1/2 degree**. All other machine list ratings – 1°, 2°, and 3° – must NOT be exceeded.

Shock Loading Caused by Barge Dynamics

Shock loads to the crane can be experienced when the barge is subjected to up and down movement of wave action (referred to as DYNAMICS). Figure 2-11 illustrates the dynamic conditions of the barge which influence crane capacity.

CAUTION

Structural Damage Hazard!

If the crane's boom or structure is shock loaded during operation, or there is any indication of shock loading, all structural components of the crane must be inspected to detect cracks and other damage. Nondestructive test equipment, such as magnetic particle or ultrasonic procedures, is recommended for this inspection.

NOTE Manitowoc does not recommend crane operation under dynamic conditions.

Operation on Barge

Machine list and/or dynamics will be experienced when a crane is operated on a barge, ship, or floating platform. Both of these conditions reduce the crane's capacity and each must be taken into account for safe operation on a barge, ship, or floating platform.

**WARNING****Tipping Crane Hazard!**

Tie-downs which only prevent the crane from shifting as in barge, ship or floating platform mounting, may not provide adequate support when using a Capacity Chart for pedestal mounting. Before operating a crane on a barge, a ship or a floating platform, the crane user shall verify that correct the Capacity Chart is being used — pedestal mounted, barge mounted, 0°, 1°, 2° or 3° list or dynamic Capacity Chart.

Failing to use the correct Capacity Chart can result in an accident.

Barge Mount Definitions

1. Machine List, as defined by Manitowoc, is the crane's out-of-level condition — from side-to-side — as measured by the angle between horizontal and a line drawn through the centerline of the crane's boom hinge pins (Figure 2-12). This out-of-level condition creates side load and affects the crane's lifting capacity.

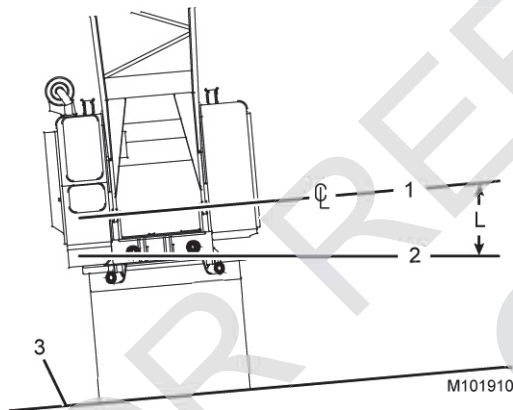

Item	Description
1	Centerline through Boom Hinge Pins
2	Horizontal
3	Barge Deck
L	Degrees of Machine List (Maximum allowable is specified in Capacity Chart)

Figure 2-12. Machine List

2. Barge List (also referred to as heel or trim) causes swing out of the load and may produce side load. When Manitowoc provides a Capacity Chart showing capacities for a 2 degree machine list for example, we

are referring to the maximum allowable lifting capacity for the crane when experiencing an out-of-level condition (side-to-side) of 2 degrees as measured by angle between horizontal and a line drawn through centerline of the crane's boom hinge pins.

Unless otherwise specified in the Capacity Chart, barge list (heel or trim) must not exceed the machine list degrees given in the Capacity Chart.

3. Barge List and Machine List are not the same. As the crane rotates on a barge, barge list (as defined above) will change. The worst machine list condition generally occurs when the crane swings over the corner of the barge, producing maximum side load.

Inspection of Barge-Mounted Crane

To aid in preventing harmful and damaging failure as previously indicated, regular inspection for signs of overloading in the following load bearing components is required. Correct each defect found before placing the crane into service.

- Boom
- Counterweight
- Backhitch
- Rotating Bed
- Wire Rope
- Pendants and Straps
- Hook and House Rollers

When equipped with hook rollers, it is recommended that each hook roller assembly be inspected daily for any sign of overloading, to include:

- Deformation of roller path
- Proper hook roller adjustment
- Deformation or cracks in hook roller hanger
- Bent hook roller shaft
- Damaged bearings

Transporting Crane on Barge

If it is necessary to transport the crane on a barge, ship, or floating platform when dynamic conditions will be experienced, the boom must be lowered onto a cradle (or other support) and the crane's boom, rotating bed, and lowerworks must be secured against movement. If the crane is equipped with a mast, the mast must be securely tied down with guylines. Failing to take these steps can result in shock load or side load damage to the boom and mast.

SECTION 3 OPERATING CONTROLS AND PROCEDURES

TABLE OF CONTENTS

Standard Hand Signals for Controlling Crane Operations	3-2
Operating Controls and Procedures	3-3
Operating Precautions	3-3
Auxiliary Frame Assembly Operating Positions	3-5

FOR REFERENCE ONLY

THIS PAGE INTENTIONALLY LEFT BLANK

FOR REFERENCE ONLY

SECTION 3 OPERATING CONTROLS AND PROCEDURES







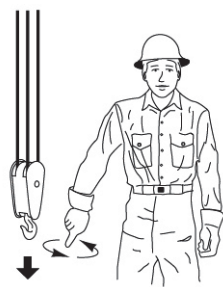
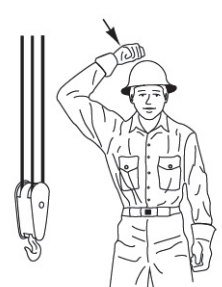
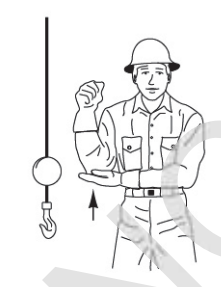
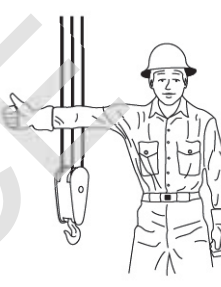

This Section Starts on the Next Page

FOR REFERENCE ONLY

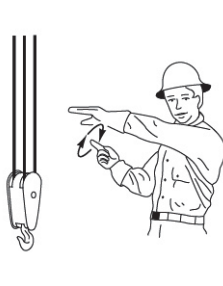
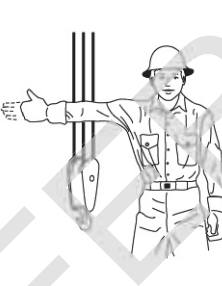
STANDARD HAND SIGNALS FOR CONTROLLING CRANE OPERATIONS

The following standard hand signals comply with ASME B30.5-2014.

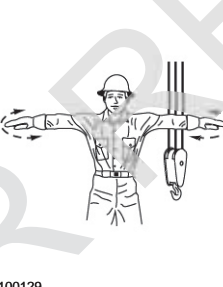
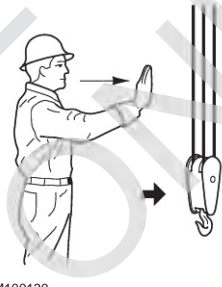
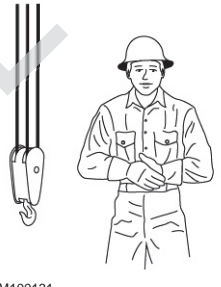
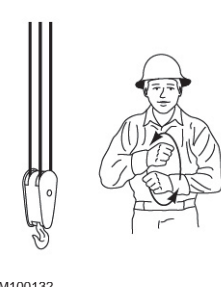
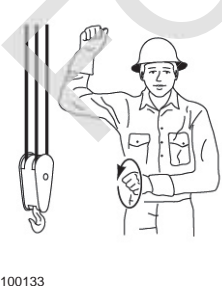
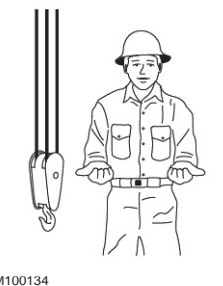
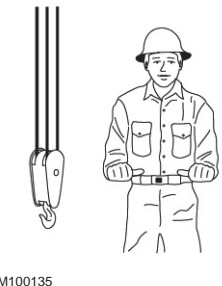
Table 3-1 Standard Hand Signals for Crane Operation

<p style="text-align: center;">1</p>  <p style="text-align: center;">M100118</p>	<p style="text-align: center;">2</p>  <p style="text-align: center;">M100119</p>	<p style="text-align: center;">3</p>  <p style="text-align: center;">M100120</p>	<p style="text-align: center;">4</p>  <p style="text-align: center;">M100121</p>	<p style="text-align: center;">5</p>  <p style="text-align: center;">M100122</p>
<p style="text-align: center;">6</p>  <p style="text-align: center;">M100123</p>	<p style="text-align: center;">7</p>  <p style="text-align: center;">M100124</p>	<p style="text-align: center;">8</p>  <p style="text-align: center;">M100125</p>	<p style="text-align: center;">9</p>  <p style="text-align: center;">M100126</p>	<p style="text-align: center;">10</p>  <p style="text-align: center;">M100127</p>
<p style="text-align: center;">11</p>  <p style="text-align: center;">M100128</p>	<p style="text-align: center;">12</p>  <p style="text-align: center;">M100129</p>	<p style="text-align: center;">13</p>  <p style="text-align: center;">M100130</p>	<p style="text-align: center;">14</p>  <p style="text-align: center;">M100131</p>	<p style="text-align: center;">15</p>  <p style="text-align: center;">M100132</p>
<p style="text-align: center;">16</p>  <p style="text-align: center;">M100133</p>	<p style="text-align: center;">17</p>  <p style="text-align: center;">M100134</p>	<p style="text-align: center;">18</p>  <p style="text-align: center;">M100135</p>	<p style="text-align: center;">19</p>  <p style="text-align: center;">M100136</p>	<p style="text-align: center;">20</p>  <p style="text-align: center;">M100137</p>

Reprinted from **ASME B30.5-2014**, by permission of the American Society of Mechanical Engineers. All Rights Reserved.

Table 3-1 Standard Hand Signals for Crane Operation

Item	Description
1	HOIST —With forearm vertical, forefinger pointing up, move hand in small horizontal circles.
2	LOWER —With arm extended downward, forefinger pointing down, move hand in small horizontal circles.
3	USE MAIN HOIST —Tap fist on head. Then use regular signals.
4	USE WHIPLINE (Auxiliary Hoist)—Tap elbow with one hand. Then use regular signals.
5	RAISE BOOM —Arm extended, fingers closed, thumb pointing upward.
6	LOWER BOOM —Arm extended, fingers closed, thumb pointing downward.
7	MOVE SLOWLY —Use one hand to give any motion signal and place other hand motionless in front of hand giving the motion signal (hoist slowly shown as an example).
8	RAISE BOOM & LOWER LOAD —With arm extended, thumb pointing up, flex fingers in and out as long as load movement is desired.
9	LOWER BOOM & RAISE LOAD —With arm extended, thumb pointing down, flex fingers in and out as long as load movement is desired.
10	SWING —Arm extended, point with finger in direction of swing of boom.
11	STOP —Arm extended, palm down, move arm back and forth horizontally.
12	EMERGENCY STOP —Both arms extended, palms down, move arms back and forth horizontally.
13	TRAVEL —Arm extended forward, hand open and slightly raised, make pushing motion in direction of travel.
14	DOG EVERYTHING —Clasp hands in front of body.
15	TRAVEL (Both Tracks)—Use both fists in front of body, making a circular motion about each other, indicating direction of travel forward or backward. (For Land Cranes Only).
16	TRAVEL (One Track)—Lock the track on side indicated by raised fist. Travel opposite track in direction indicated by circular motion of other fist, rotated vertically in front of body. (For Land Cranes Only).
17	EXTEND BOOM (Telescoping Booms)—Both fists in front of body with thumbs pointing outward.

OPERATING CONTROLS AND PROCEDURES

Read and become thoroughly familiar with the instructions in Section 3 of the MLC300 Crane Operator Manual.

OPERATING PRECAUTIONS



WARNING

Observe the following operating precautions to prevent tipping or structural failure of the attachment.

- Read and become thoroughly familiar with the instructions in the RCL/RCI Operation Manual.
- Make sure the RCL/RCI is properly configured as instructed under the topic Entering Boom Configuration in the RCL/RCI Operation Manual.
- Read and comply with the instructions in the VPC-MAX Maximum Allowable Travel Specifications Chart. The chart contains counterweight requirements for travel and swing without load.
- Make sure the load sensing pins are operating properly. Otherwise, the counterweight assembly will not extend and retract automatically when required.
- Make sure the VPC-MAX limit switches are adjusted and operating properly. Otherwise, the counterweight assembly will not extend and retract automatically when required.
- Adhere to the boom raising and lowering limitations given in the Capacity Charts. Block the crawlers if specified and make sure the proper counterweight position column of the capacity chart is selected before raising or lowering the boom.
- Read and comply with the instructions in the Crane Operator Manual and in the VPC-MAX Capacity Charts before operating the crane. Do not operate beyond the limits given.
- If equipped with a luffing jib, also read the instructions in the Luffing Jib Operator Manual and in the Luffing Jib Capacity Charts. Do not operate beyond the limits given.
- Make sure the proper counterweight is installed.
- Read and become thoroughly familiar with the instructions in the Main Display Operation Manual.

- If required per the rigging drawing in use (boom and luffing jib), make sure the intermediate suspension is properly installed. Otherwise, damage to the boom and jib sections can occur.

For some boom and luffing jib configurations, it is normal for the intermediate suspension to appear slack during boom and luffing jib raising and operation. If your intermediate suspension appears slack —

- make sure it is installed in the proper location,
- make sure the proper pendant buttons are pinned to the sockets,

and continue operation.

- The counterweight assembly will remain in its last position when the engine is turned off during operation.
- Operate only with the crane on a firm surface that is uniformly supporting:
 - **With load**, grade must not exceed 1% in any direction — 1 ft in 100 ft (0,3 m in 30 m).
 - **Without load**, see Maximum Allowable Travel Specifications Chart.
 - During crane operation, the elevation outside of the crawlers may be up to 102 mm (4 in) above the grade of the crawlers to 460 mm (18 in) below the grade of the crawlers. Also, the grade outside of the crawlers shall not exceed 4% in any direction.

These conditions apply to any area the auxiliary frame assembly will pass over.

- Prior to using the crane each day, inspect the VPC and VPC-MAX roller paths on the rotating bed and beam for obvious obstructions and/or signs of damage. Remove the obstructions. Contact the Manitowoc Crane Care Lattice Team for inspection and repair criteria.
- Do not operate the crane, to include raising the boom from ground level, if the wind exceeds the limits given in Capacity Charts. Monitor the wind speed in the working screen of the crane's RCL/RCI Display or contact your local weather station. See Wind Conditions in the Capacity Chart Manual.
- Be aware of increased tail swing with the VPC-MAX counterweight assembly. The counterweight assembly can strike objects or personnel in the area of the travel and swing paths.
- Warn all personnel to stand well clear of the crane. The VPC-MAX counterweight assembly extends and retracts automatically — it can strike personnel.

Anytime the VPC-MAX counterweight assembly moves, an audible alarm will sound and the amber lights on the counterweight tray and beam will flash to warn personnel to stay clear.

- Provide a signal person for all crane operations.

Have signal person watch for clearance behind and under the counterweight assembly while swinging and traveling. Do not allow the counterweight to strike obstructions or contact the foundation.

Depending on lifted load, clearance under the auxiliary frame assembly will vary from 230 mm (9 in) to 1,1 m (3.7 ft).

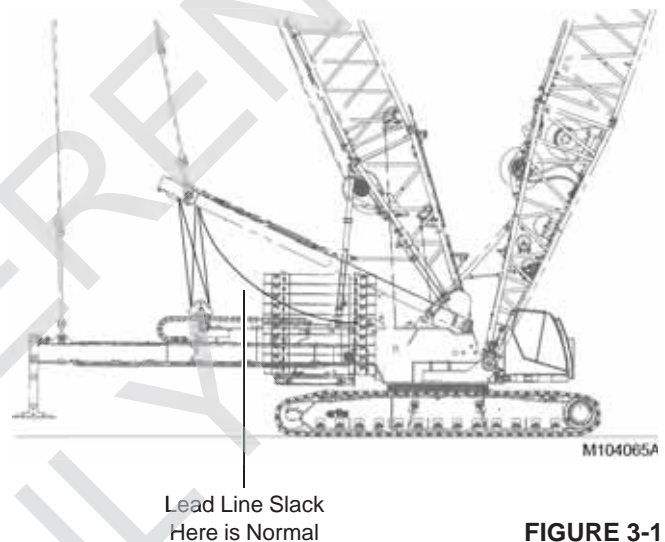

FIGURE 3-1

- During operation, it is normal for the lead line of the live mast wire rope reeving to become slack (Figure 3-1) when the counterweight tray is at the minimum working position. This most commonly occurs when operating at high boom angles with light loads.

When this condition occurs, the VPC-MAX beam will be supported by the beam hooks resting on the rotating bed pins.

If the wire rope between the live mast and the rotating bed equalizer become visibly loose, check that the wire rope is seated in all sheave grooves before continuing operation.

- When the crane is left unattended, park it as instructed in the Shutdown Procedure in Section 3 of the Crane Operator Manual.

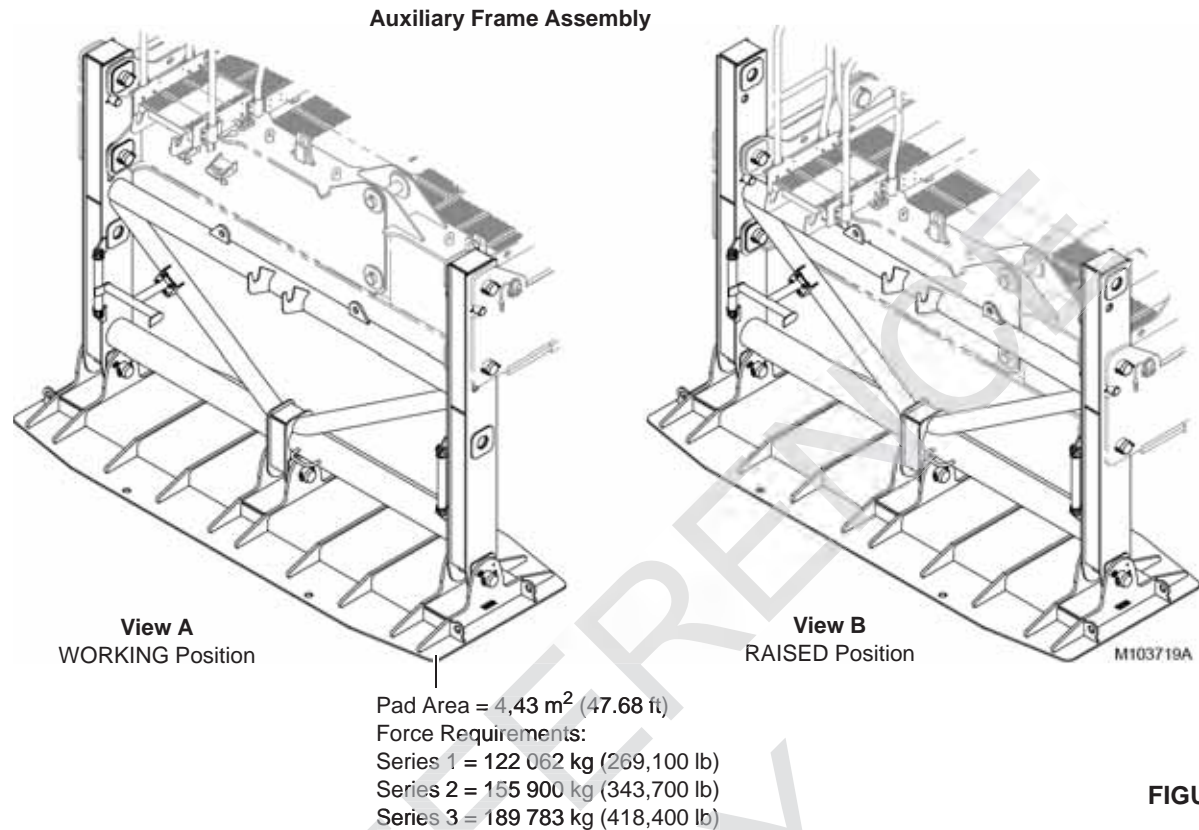

FIGURE 3-2

AUXILIARY FRAME ASSEMBLY OPERATING POSITIONS



WARNING

Death or Serious Injury Hazard!

A sudden release of load and/or dynamic loading (due to swinging, hoisting, or lowering and adverse weather conditions to include wind) may cause structural damage which could result in death or serious injury due to shock loading and unintended motion of the crane.

The auxiliary frame assembly is provided to limit unintended motion of the VPC-MAX beam and counterweights during a sudden release of load and/or dynamic loading (due to swinging, hoisting, or lowering and adverse weather conditions to include wind).

The auxiliary frame assembly in no way substitutes for, or lessens, the requirement that the crane must be operated properly and safely, and that it must be inspected, serviced, and maintained regularly to minimize the potential for a sudden release of load and/or dynamic loading (due to swinging, hoisting, or lowering and adverse weather conditions to include wind).

The auxiliary frame assembly (Figure 3-2) has two operating positions:

WORKING Position (View A):

This is the recommended operating position.

RAISED Position (View B):

This position can be used if additional clearance is required for swinging over job site obstacles.

Lower the auxiliary frame assembly after the obstacle is cleared. Continued operation with the auxiliary frame assembly raised is not recommended.

To change the operating position, see Auxiliary Frame Operating Positions in Section 4 of this manual.

THIS PAGE INTENTIONALLY LEFT BLANK

FOR REFERENCE ONLY

SECTION 4

SET-UP AND INSTALLATION

TABLE OF CONTENTS

General Set-Up and Installation	4-1
General Safety	4-1
Crane Orientation	4-2
Boom and Jib Assembly Drawings	4-2
Accessing Parts	4-2
Personal Fall-Protection	4-2
Handling Components	4-2
Assist Crane Requirements	4-3
Crane Weights and Shipping Data	4-3
Parts Box	4-3
Lifting Slings and Shackles	4-3
Retaining Connecting Pins	4-3
Remote Control	4-6
Activating Remote Control	4-7
Starting Engine with Remote Control	4-7
Crane and VPC-MAX Setup	4-7
Pin and Connecting Hole Cleanliness	4-8
Hose and Cable Cleanliness	4-8
Hydraulic Hose Identification	4-8
Connecting/Disconnecting Hydraulic Hoses and Electric Cables	4-8
Tightening Hydraulic Couplers	4-8
Operating Conditions During Assembly and Disassembly	4-11
Installing VPC-MAX Beam and Trolley	4-13
Prepare Crane	4-13
Check VPC Trolley Travel Limits and Calibration	4-13
Prepare VPC Trolley	4-15
Store Exhaust Shield on Crane	4-15
Remove VPC-MAX Beam from Trailer	4-17
Unfold VPC-MAX Beam	4-19
Remove Handrails from VPC-MAX Beam	4-21
Attach VPC-MAX Beam to VPC Trolley	4-23
Connect VPC-MAX Beam-to-VPC Trolley Electric Cable	4-27
Connect VPC-MAX Beam-to-VPC Trolley Hydraulic Hoses	4-27
Hook VPC-MAX Beam to Rotating Bed	4-29
Remove Counterweight Tray from Trailer	4-31
Prepare Counterweight Tray	4-31
Remove VPC-MAX Trolley from Trailer	4-33
Adjust VPC-MAX Trolley Wear Pads	4-33
Adjust VPC-MAX Trolley Scrapers	4-33
Install Trolley Installation Guides	4-35
Attach VPC-MAX Trolley to Counterweight Tray	4-37
Install VPC-MAX Trolley and Counterweight Tray	4-39
Connect VPC-MAX Energy Chain to VPC-MAX Trolley	4-41
Connect VPC-MAX Trolley Electric Cables	4-41
Connect VPC-MAX Trolley Hydraulic Hoses	4-41
Check VPC-MAX Trolley Travel Limits and Calibration	4-43
Install Auxiliary Frame Assembly	4-43
Install Handrails	4-45
Install VPC-MAX Beam Ladder	4-47
Position Counterweight Tray In Minimum Position	4-49
Calibrate Position of VPC-MAX Trolley	4-49

Installing VPC-MAX #503 Fixed Mast	4-51
Remove Fixed Mast Butt and Top Assembly from Trailer	4-51
Verify Mast Stop Accumulator Pressure	4-51
Raise Mast Stops	4-51
Connect Fixed Mast Butt and Top Assembly to Crane	4-53
Connect Fixed Mast Hydraulic Hoses	4-55
Connect Fixed Mast Electric Cable	4-55
Connect Fixed Mast Camera Cables	4-55
Disconnect Fixed Mast Top from Fixed Mast Butt	4-57
Assemble and Install Fixed Mast Inserts	4-59
Store Handling Pendants	4-61
Store Self-Erect Cylinder	4-61
Connect Straps at Mast Top	4-63
Test Mast Stop Limit Switch	4-63
Connect Straps at Mast Inserts	4-65
Connect Straps at Mast Butt	4-67
Connect Live Mast Straps to Fixed Mast	4-68
Lower Live Mast Assist Arms	4-69
Configure Fixed Mast in RCL/RCI Display	4-69
Fixed Mast Raising Methods	4-71
Target Tension During Fixed Mast Raising and Lowering	4-71
Raising Fixed Mast — Preferred Method with Boom Holdback	4-73
Disconnect Boom Hoist Equalizer from Mast Top	4-73
Raise Fixed Mast to Boom Rigging Position	4-73
Install Counterweight Boxes	4-75
Assemble Partial Boom	4-75
Install Partial Boom	4-77
Assemble Remaining Boom Sections	4-79
Connect Boom Straps	4-79
Connect Boom Sections	4-81
Finish Assembling Boom	4-81
Connect Equalizer Links to Boom Straps	4-83
Raise Fixed Mast to Operating Position	4-83
Adjust Fixed Mast and Beam Position	4-85
Raise Boom	4-85
Raising Fixed Mast — Alternate Method with Anchored Holdback	4-86
Disconnect Boom Hoist Equalizer from Mast Top	4-86
Anchor Boom Hoist Equalizer to Holdback	4-87
Raise Fixed Mast	4-87
Install Boom	4-91
Install Boom Hoist Equalizer on Equalizer Rails	4-91
Connect Equalizer Links to Boom Straps	4-91
Install Counterweight Boxes	4-91
Adjust Fixed Mast and Beam Position	4-91
Raise Boom	4-91
Raising Boom	4-92
Pre-Raising Checks	4-92
Boom Raising Procedure	4-93
Auxiliary Frame Operating Positions	4-95
Shipping Crane Components	4-97
Lowering Boom	4-97
Fixed Mast Lowering Methods	4-99
Lowering Fixed Mast — Preferred Method with Boom Holdback	4-99
Disconnect Counterweight Straps	4-99
Lower Fixed Mast to Disassembly Position	4-101
Disconnect Equalizer Links from Boom Straps	4-101
Prepare Boom for Removal	4-101

Disconnect Boom Sections	4-103
Disconnect Boom Straps	4-105
Disassemble Boom Sections	4-105
Remove Partial Boom	4-107
Disassemble Partial Boom	4-109
Remove Counterweight Boxes	4-109
Lower Fixed Mast to Disassembly Position	4-109
Connect Boom Hoist Equalizer to Mast Top	4-109
Lowering Fixed Mast — Alternate Method with Anchored Holdback	4-111
Remove Counterweight Boxes	4-111
Remove Boom Hoist Equalizer from Equalizer Rails	4-111
Remove Boom	4-111
Anchor Boom Hoist Equalizer to Holdback	4-113
Disconnect Counterweight Straps	4-113
Lower Fixed Mast	4-113
Connect Boom Hoist Equalizer to Mast Top	4-113
Removing VPC-MAX #503 Fixed Mast	4-115
Raise Live Mast Assist Arms	4-115
Configure Live Mast in RCL/RCI	4-115
Disconnect Live Mast Straps from Fixed Mast	4-115
Disconnect and Store Straps at Mast Top	4-117
Disconnect and Store Straps at Mast Inserts	4-119
Disconnect and Store Straps at Mast Butt	4-121
Deploy Self-Erect Cylinder	4-123
Connect Handling Pendants	4-123
Store Load Lines	4-125
Remove Fixed Mast Top	4-125
Remove and Disassemble Fixed Mast Inserts	4-125
Connect Fixed Mast Top to Fixed Mast Butt	4-127
Disconnect Fixed Mast Hydraulic Hoses	4-129
Disconnect Fixed Mast Electric Cable	4-129
Disconnect Fixed Mast Camera Cables	4-129
Disconnect Fixed Mast Butt and Top Assembly from Crane	4-131
Lower Mast Stops	4-133
Install Fixed Mast Butt and Top Assembly on Trailer	4-133
Removing VPC-MAX Beam and Trolley	4-135
Remove Handrails	4-135
Remove Auxiliary Frame Assembly	4-137
Install Hose/Cable Storage Brackets	4-139
Position VPC-MAX Trolley at End of Beam	4-141
Attach Lifting Slings to Counterweight Tray	4-141
Install Trolley Installation Guides	4-143
Disengage Trolley Drive Pinions from Gear Racks	4-145
Disconnect VPC-MAX Trolley Hydraulic Hoses	4-147
Disconnect VPC-MAX Trolley Electric Cables	4-147
Disconnect VPC-MAX Energy Chain from VPC-MAX Trolley	4-147
Remove VPC-MAX Trolley and Counterweight Tray	4-149
Remove VPC-MAX Trolley from Counterweight Tray	4-151
Install Counterweight Tray on Trailer	4-151
Unhook VPC-MAX Beam from Rotating Bed	4-153
Disconnect VPC-MAX Beam-to-VPC Trolley Electric Cable	4-155
Disconnect VPC-MAX Beam-to-VPC Trolley Hydraulic Hoses	4-155
Disconnect VPC-MAX Beam from VPC Trolley	4-157
Store Handrails in VPC-MAX Beam	4-159
Fold VPC-MAX Beam for Shipping	4-161
Install VPC-MAX Beam on a Trailer	4-163
Complete Disassembly	4-163
Wire Rope Installation	4-163

THIS PAGE INTENTIONALLY LEFT BLANK

FOR REFERENCE ONLY



SECTION 4

SET-UP AND INSTALLATION

GENERAL SET-UP AND INSTALLATION

This section contains installation and removal instructions for the VPC-MAX, the fixed mast, and the boom.

For set-up and installation of the luffing jib, see the instructions in Section 4 of the Luffing Jib Operator Manual.

The attachment must be installed, operated, and removed by experienced personnel trained in erection and operation of construction cranes.

Before attempting to install, operate, or remove the attachment, the experienced personnel shall read and become thoroughly familiar with the following:

- The instructions in the applicable capacity charts located in the Capacity Chart Manual or at the end of this section
- The safety, installation, and removal procedures in this section
- The instructions in the Boom and Jib Rigging Drawings located at the end of this section

Contact the Manitowoc Crane Care Lattice Team for a detailed explanation of any procedure you do not fully understand.

GENERAL SAFETY

To prevent accidents that can result in death or injury during crane assembly and disassembly, comply with the following general safety information and with specific safety information contained in assembly and disassembly steps.



WARNING

Death or Serious Injury Hazard!

Read and understand the instructions in this section before attempting to install or remove the attachment.

Tipping/Overload Hazard!

Avoid tipping the crane over or collapsing the fixed mast:

- Install and remove the attachment on a firm, level, uniformly supporting surface.
Level = 1% of grade or
0,30 m (1 ft) in 30,5 m (100 ft)
- The area selected must be large enough to accommodate the crane, the selected boom and jib length, and movement of an assist crane.



WARNING

Avoid Falling Off Crane and Boom!

It is necessary to climb onto the crane and attachment during the installation and removal steps.

Use sturdy owner furnished ladders or an approved personnel hoist to gain access to areas which cannot be reached from the ladders or steps provided with the crane and attachment.

Moving Parts/Pinch Points!

Avoid death or crushing injury during installation and removal:

- Assembly personnel — take every precaution to prevent injury when working near moving parts.
- Maintain communication between operator and assemblers to avoid accidents.
- Do not raise or lower either mast until all personnel are off the crane.
- Keep unauthorized personnel well clear of the crane.

Falling Load Hazard!

To prevent the lifting equipment from failing and the load from dropping, the crane owner/user shall verify the following prior to each lift:

- The assist crane has been properly maintained and is safe for use.
- All lifting equipment (shackles, hooks, slings, blocks) has been properly maintained and is safe for use.
- All lifting equipment has a capacity equal to or greater than load to be lifted.



M101966

Item	Description
1	Lifeline
2	Anchor



M101967

Figure 4-1

CRANE ORIENTATION

The terms RIGHT, LEFT, FRONT, REAR used in this section refer to the operator's right, left, front, and rear sides when seated in the operator cab looking forward.

- The operator cab is at the front of the upperworks.
- A yellow arrow and dot on the right top and right front sides of the carbody indicate the FRONT of the carbody.

BOOM AND JIB ASSEMBLY DRAWINGS

The Boom and Jib Rigging drawings that apply to your crane are located at the end of this section.

ACCESSING PARTS

! WARNING
Fall Hazard!

To avoid serious injury, the owner/user shall provide workers with approved ladders or aerial work platforms to access those areas of the crane, either mast, and the boom that cannot be reached from the ground or from Manitowoc-provided steps, ladders, catwalks and platforms.

Adhere to local, state, and federal regulations for handling personnel and personnel fall protection.

Some parts of the crane and attachment cannot be reached from the ground. Take the necessary precautions to prevent slipping and/or falling off the crane and attachment during installation, removal, maintenance, or other work. **Falling from any height could result in serious injury or death.**

PERSONAL FALL-PROTECTION

Manitowoc has provided lifelines and anchors throughout the crane and attachment (see Figure 4-1) to which workers can attach their personal fall-protection equipment.

! WARNING
Fall Hazard!

To prevent falling from any height during attachment installation and removal, personnel shall wear fall-protection equipment.

- Anchors and lifelines are designed to handle only one person at a time.
- Do not use anchors for lifting or pulling loads.

HANDLING COMPONENTS

The major components are equipped with lifting lugs. The lifting lugs are identified by the following symbol in the installation and removal illustrations.

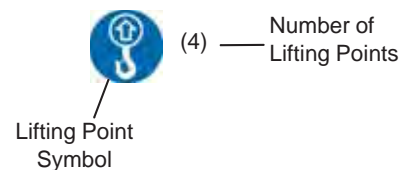

Figure 4-2

When lifting lugs are not provided, use nylon lifting slings to lift the components. If wire rope or chain slings are used, install protective covering (such as sections of rubber tire) between the slings and the component being lifted.

It is the crane owner's/user's responsibility to ensure that all lifting slings, hooks, and shackles are in safe working order and capable of handling the load applied to them.

In some cases, a forklift is required to lift components. When required, the lift points are identified by the following symbol in the installation and removal illustrations.

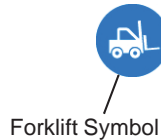

Figure 4-3

ASSIST CRANE REQUIREMENTS

An assist crane is required to install and remove parts.

The heaviest individual weight to be lifted is the fixed mast butt, top, and boom hoist equalizer package (see View A, [Figure 4-31 on page 4-50](#)) which weighs approximately 18 144 kg (40,000 lb).

The crane owner/user shall ensure that all rigging used to handle loads (hooks, slings, shackles, etc.) and the assist crane are in safe, proper working order and sized to lift the applicable load.

CRANE WEIGHTS AND SHIPPING DATA

- See the Crane Weights topic in Section 1 of this manual for the weights of individual crane components.
- See the MLC300 Product Guide in Section 1 of this manual for outline and shipping dimensions.

PARTS BOX

Manitowoc provides a parts box that can be lifted with a forklift.

The following types of parts are shipped in the parts box:

- Lifting slings, links, and shackles
- Quick-disconnect wrenches
- Quick-drain drainer assembly (for oil changes)
- Touch-up paint
- Spray lubricant
- VPC (variable position counterweight) hose supports
- Camera parts
- Button sockets, links, swivels, and pins
- APU (auxiliary power unit) hoses and cables

Carefully inventory the parts boxes according to the parts diagram on the parts box.

LIFTING SLINGS AND SHACKLES

Manitowoc has provided the lifting slings, shackles, and link shown in [Figure 4-4](#) and [Figure 4-5](#).

RETAINING CONNECTING PINS

Connecting pins are retained in various ways:

- Wire-lock pins
- Quick-release pins
- Cotter pins
- Hitch pins
- Safety pins
- Keeper plates with cap screws and lock washers

Do not operate the crane until all connecting pins are installed and properly retained.

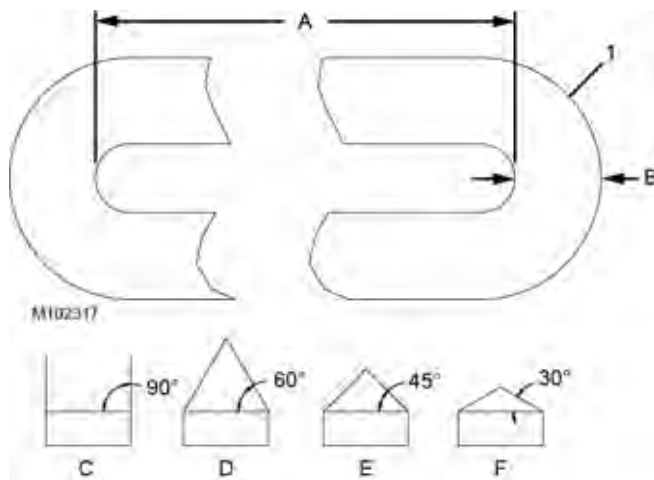

Item	Description	
1	Endless Synthetic Rope Sling Working Load Limit: 18 144 kg (40,000 lb) Straight 14 515 kg (32,000 lb) Chocker 36 287 kg (80,000 lb) Basket Four Supplied by Manitowoc	
Item	m	ft
A	2,8	9
Item	mm	in
B	59,7	2-11/32
Item	kg	lb
C	18 144	40,000
D	15 712	34,640
E	12 828	28,280
F	9 072	20,000

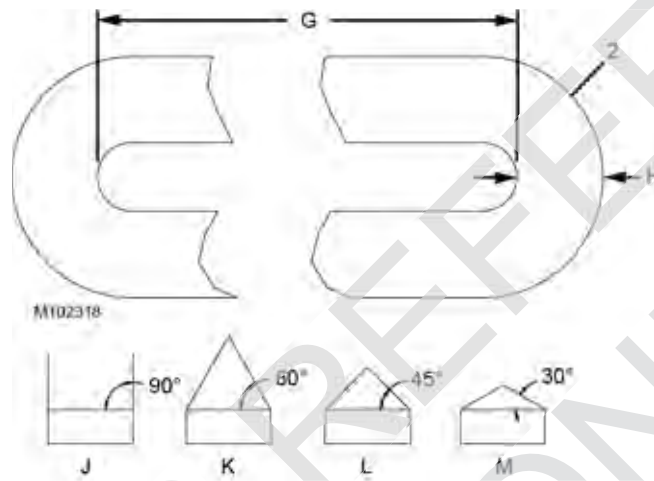

Item	Description	
2	Endless Synthetic Rope Sling Working Load Limit: 18 144 kg (40,000 lb) Straight 14 515 kg (32,000 lb) Chocker 36 287 kg (80,000 lb) Basket Four Supplied by Manitowoc	
Item	m	ft
G	4	13.0
Item	mm	in
H	59,7	2-3/8
Item	kg	lb
J	18 144	40,000
K	15 712	34,640
L	12 828	28,280
M	9 072	20,000

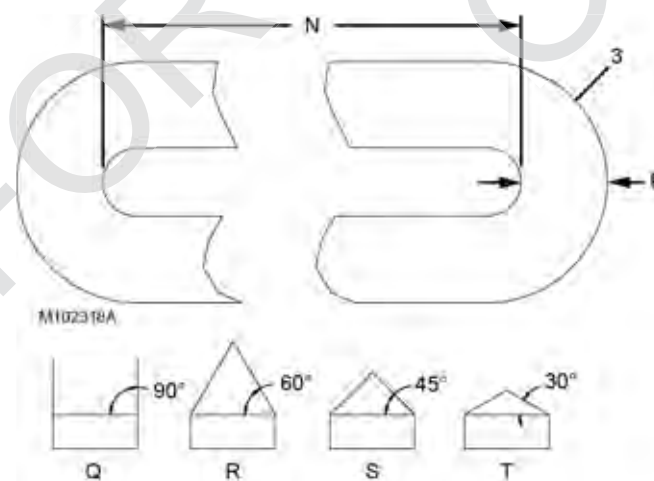

Item	Description	
3	Endless Synthetic Rope Sling Working Load Limit: 22 680 kg (50,000 lb) Straight 18 144 kg (40,000 lb) Chocker 45 359 kg (100,000 lb) Basket Two Supplied by Manitowoc	
Item	m	ft
N	1,87	6.1
Item	mm	in
P	47,6	1-7/8
Item	kg	lb
Q	22 680	50,000
R	19 641	43,300
S	16 035	35,350
T	11 340	25,000

Figure 4-4

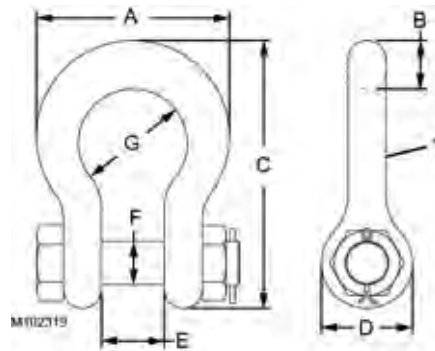

Item	Description
1	Shackle: 25 t (28 USt) Six Supplied by Manitowoc

Item	mm	in
A	225,0	8.86
B	57,0	2.25
C	313,0	12.34
B	106,0	4.19
E	73,0	2.88
F	51,0	2.00
G	127,0	5.00

- NOTE**
- Two shackles are shipped in parts box.
 - Two shackles are attached to boom hoist equalizer.
 - Two shackles are attached to 12 m insert with rails.

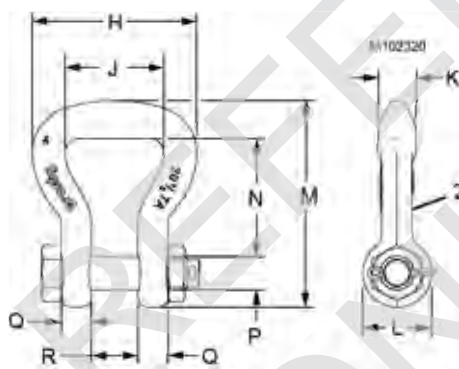

Item	Description
2	Shackle: 20,5 t (23 USt) Four Supplied by Manitowoc

Item	mm	in
H	190,5	7.5
J	114,3	4.5
K	44,5	1.75
L	79,2	3.12
M	240,0	9.45
N	136,5	5.37
P	38,9	1.53
Q	35,1	1.38
R	54,1	2.13

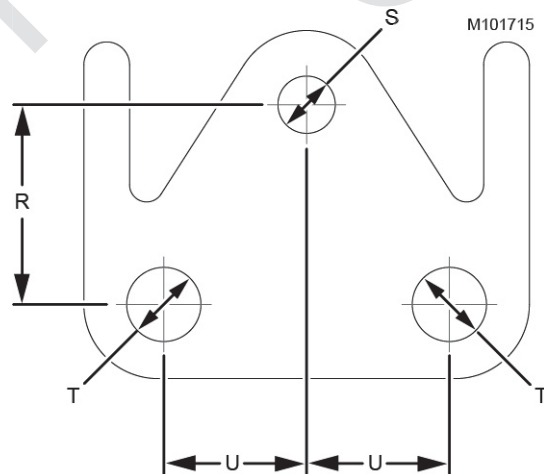

Item	Description
3	Lifting Link: 40 t (44 USt) Attached to Self-Erect Cylinder

Item	mm	in
R	175,0	6.89
S	50,2	1.98
T	65,0	2.56
U	125,0	4.92

Figure 4-5

Item	Description
1	Operator Cab
2	Storage Compartment
3	Remote Control
4	Electric Cable: 20 m (66 ft)
5	Transceiver
6	Front of Rotating Bed
7	DC Load Center
8	External Engine Switch

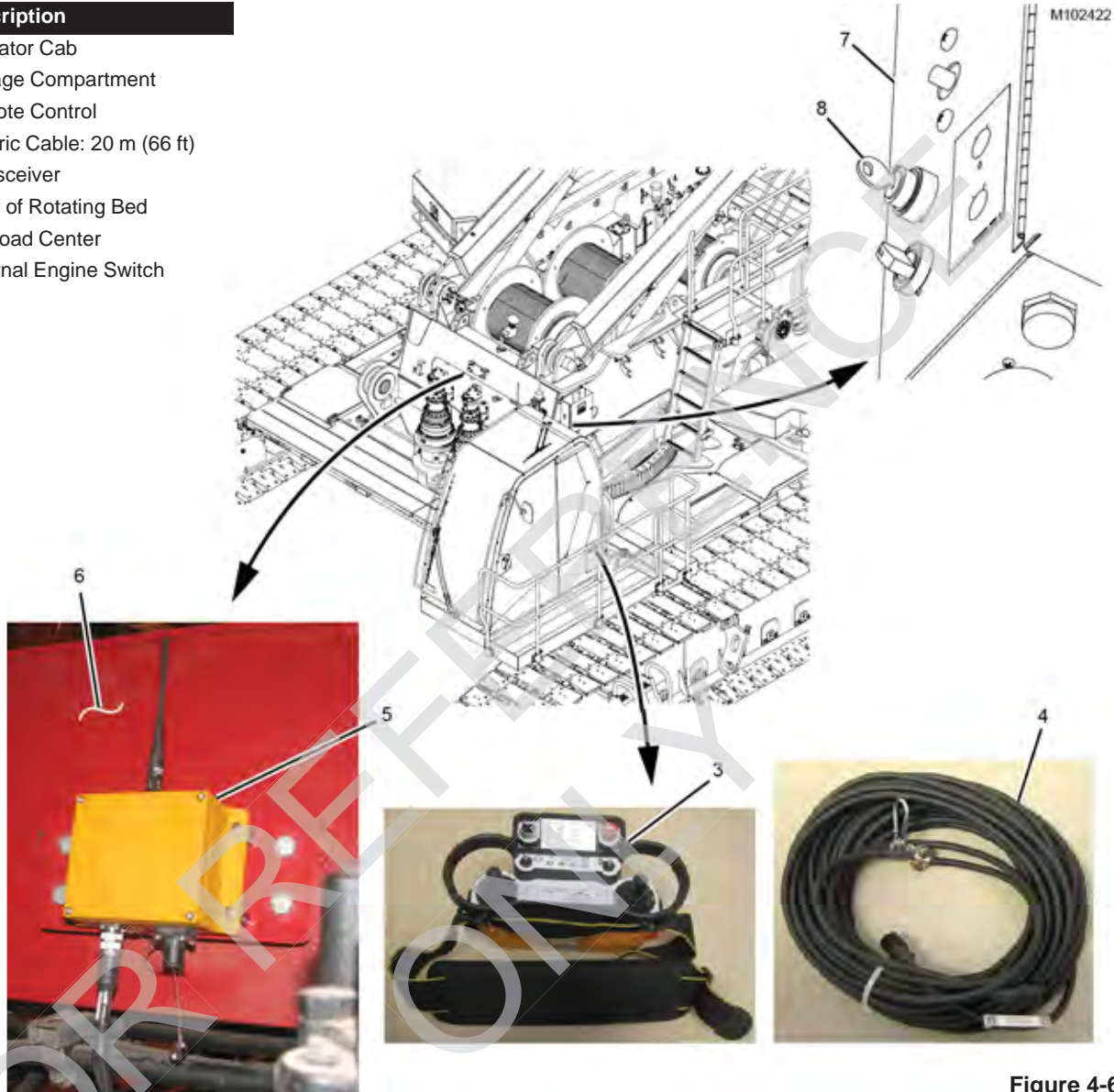

Figure 4-6

REMOTE CONTROL

See [Figure 4-6](#) for the following procedure.

For identification and operation of the self-erect controls provided on the remote control, refer to Section 3 of the Crane Operator Manual.

Do not operate the self-erect controls without first reading Section 3 of Crane Operator Manual and the applicable procedures in this section.

NOTE The speed of all self-erect functions depends on engine speed: the faster the engine speed, the faster the self-erect functions (and vice versa).

The remote control can be operated without the electric cable (4) if job site conditions allow for a wireless signal.

If you are unable to get a wireless signal, connect the electric cable (4) between the receptacle on the remote control (3) and the receptacle on the transceiver (5).

Controls for the following functions are provided on the remote control (3):

- Engine start, stop, and speed
- Counterweight tray pins
- Boom hinge pins

- Mast assist arms and cylinders (for manually lowering mast assist arms; also provided in cab)
- Live mast hinge pins
- Cab tilt
- Carbody jacks
- Rigging winch
- VPC travel in and out
- VPC-MAX travel in and out
- Crawler pins
- Crawler track tension
- Boom hoist equalizer hinge pins
- Horn

Activating Remote Control

To activate the remote control upon arriving at the job site, proceed as follows:

1. Remove the remote control (3) from the storage compartment (2) on the side of the operator cab (1).
2. Using the key provided, turn the external engine switch (8) CLOCKWISE to the RUN position.
3. Turn the power switch on the side of the remote control CLOCKWISE to the ON (I) position. The communication light on the remote control will flash green.
4. Press the communication switch on the side of the remote control for approximately one second and release it. The function light on the remote control for the last function used will glow green.

The remote control will remain active until the external engine switch (8) is turned COUNTERCLOCKWISE to the STOP position OR the remote control is deactivated in the Remote Control Selection Screen in the Main Display (see MLC300 Main Display Operation Manual).

NOTE The remote control can also be activated in the Remote Control Selection Screen in the Main Display.

The remote control will also turn off (go to sleep) after 10 minutes of non-use. If this happens, press the communication switch on the side of the remote control for approximately one second and release it to re-establish communication.

Starting Engine with Remote Control

To start the engine using the remote control:

1. Activate the remote control.
2. Read the Startup Procedures in Section 3 of this manual.
3. Turn the power switch on the side of the remote control CLOCKWISE to the START position to start the engine.
4. Release the power switch to the ON (I) position as soon as the engine starts.

NOTE To stop the engine when using the remote control, turn the external engine switch (8) COUNTERCLOCKWISE to the STOP position

CRANE AND VPC-MAX SETUP

- To use the remote control during crane and VPC-MAX assembly and disassembly, the remote control must be activated in the Remote Control Selection Screen in the Main Display. See the MLC300 Main Display Operation Manual for instructions.

- To use the live mast during crane and VPC-MAX assembly and disassembly, the following steps are required:

- The live mast must be configured in the RCL/RCI Display. See the MLC300 RCL/RCI Display Operation Manual for instructions.

This step allows operation of Drum 4 to raise and lower the live mast and to operate Drum 5 when Drum 6 is parked.

- The self-erect cylinder (on live mast) must be turned on in the Self-Erect Cylinder Selection Screen in the Main Display.

This step allows the cylinder to be operated with the center drum control handle.

- To use the fixed mast during crane and VPC-MAX assembly and disassembly, the following step is required:

- The fixed mast must be configured in the RCL/RCI Display. See the MLC300 RCL/RCI Display Operation Manual for instructions.

This step allows the fixed mast to be used as a boom. Drum 4 raises and lowers the fixed mast and Drum 5 hauls in and pays out the equalizer (load hoist).

PIN AND CONNECTING HOLE CLEANLINESS

To prevent dirt from damaging closely machined surfaces of pins and connecting holes:

- Thoroughly clean all pins and connecting holes.
- Apply a light coat of grease to all pins and connecting holes.

HOSE AND CABLE CLEANLINESS

To prevent dirt from entering the hydraulic systems or from damaging the electric connectors:

- Thoroughly clean the hydraulic fittings and the electric connectors before connecting them.
- Thoroughly clean the dust caps before attaching them to hoses, tubes, or cables.
- Do not drag the hydraulic hose fittings, the hydraulic hoses, the electric cable connectors, or the electric cables on the ground.

NOTE Apply a light coat of silicone lubricant to the threads of all dust caps, couplers, and connectors to help in preventing the threads from seizing.

HYDRAULIC HOSE IDENTIFICATION

Where necessary, the hydraulic hoses and corresponding couplers have identification tags as shown in [Figure 4-7](#). Match the number on the hose with the number on the corresponding coupler to ensure proper connection.

CONNECTING/DISCONNECTING HYDRAULIC HOSES AND ELECTRIC CABLES

Always STOP ENGINE before performing the following steps during crane assembly and disassembly:

- Connecting and disconnecting hydraulic lines. It will be easier to connect and disconnect the couplers when there is no pressure in the system.
- Connecting and disconnecting electric cables. The potential for operating faults or damage to the electric components exists if the engine is not stopped.

NOTE To stop the engine if it was started from the remote control, turn the external engine switch (8, [Figure 4-6 on page 4-6](#)) COUNTERCLOCKWISE to the STOP position.

To stop the engine if it was started from the cab, use the ignition switch in the cab.

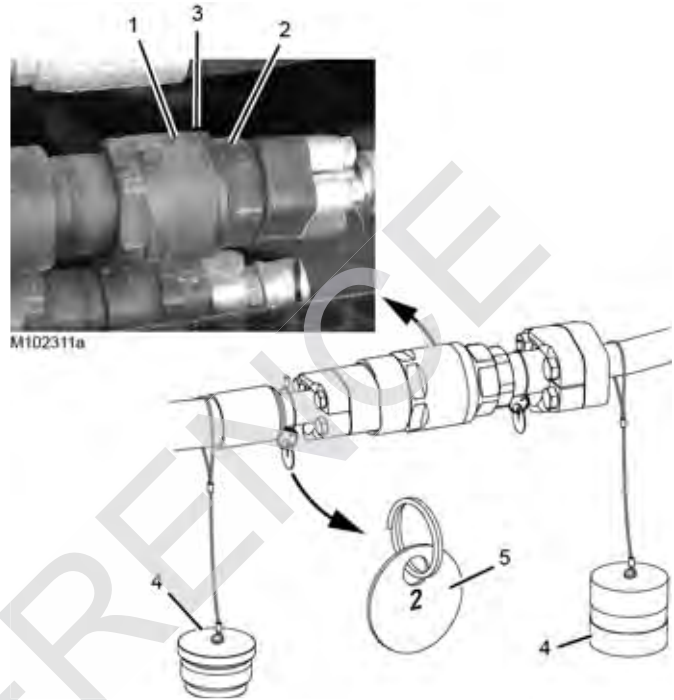

Item	Description
1	Coupler
2	Nipple
3	O-ring (not visible)
4	Dust Cap
5	Identification Tag

Figure 4-7

TIGHTENING HYDRAULIC COUPLERS

Connect each screw-to-connect coupler and nipple ([Figure 4-7](#)), as follows:

1. Lubricate coupler (1) threads, nipple (2) threads, and nipple O-ring (3) with clean hydraulic oil.
2. Hand tighten coupler (1) onto nipple (2).
3. Using opened-end wrenches, tighten the coupler until there is metal-to-metal contact between the coupler and the nipple. **O-ring (3) must not be visible.**

To avoid damage, do not exceed a torque of:

- Size -06 = 1.62 lbf ft (2,2 Nm)
- Size -08 = 1.33 lbf ft (1,8 Nm)
- Size -12 = 4.13 lbf ft (5,6 Nm)
- Size -20 = 6.04 lbf ft (8,2 Nm)
- Size -24 = 19.16 lbf ft (26,0 Nm)

4. Check for leaks after the crane has been operated and the hydraulic oil is at operating temperature. Re-tighten the couplers if necessary.

FOR REFERENCE ONLY

THIS PAGE INTENTIONALLY LEFT BLANK

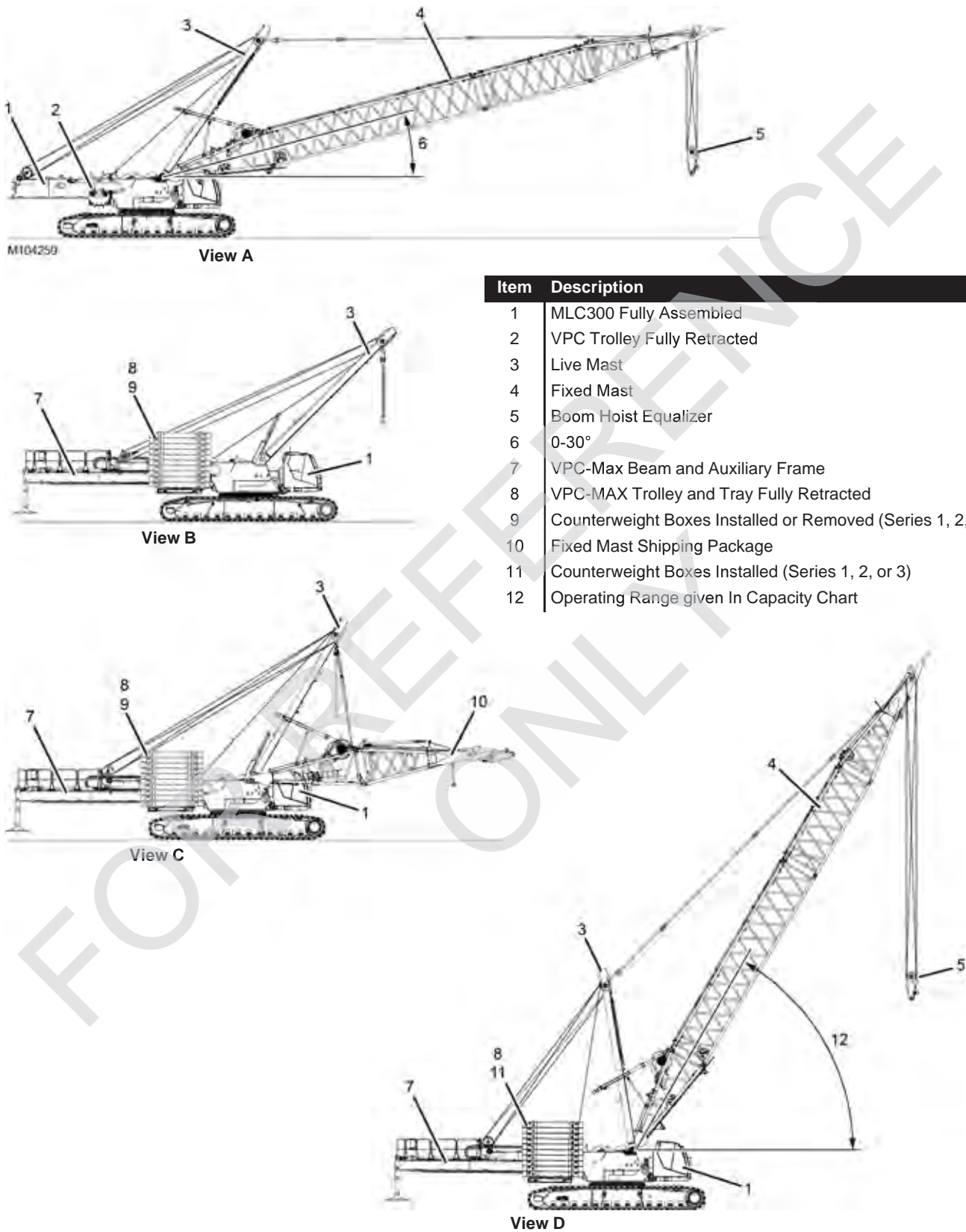

Figure 4-8

OPERATING CONDITIONS DURING ASSEMBLY AND DISASSEMBLY

Crane Configuration (see Figure 4-8)	Machine Stable	Swing and Travel
Crane configured as shown in View A: <ul style="list-style-type: none"> • Live mast and fixed mast installed • Fixed mast at 0° to 30° above horizontal • Boom hoist equalizer suspended from fixed mast • VPC trolley installed and fully retracted • No VPC-MAX trolley, beam, or counterweight boxes installed 	Yes	Can swing 360° and travel: <ul style="list-style-type: none"> • Travel surface must be firm, level, and uniformly supporting • Grade in any direction must not exceed 1% (0.5°)
Crane configured as shown in View B: <ul style="list-style-type: none"> • Fixed mast not installed • Live mast lowered forward to 135° • VPC-MAX trolley, beam, and auxiliary frame installed • VPC-MAX counterweight tray installed and fully retracted • Series 1, 2, or 3 counterweight boxes installed or removed 		
Crane configured as shown in View C: <ul style="list-style-type: none"> • Fixed mast shipping package installed and supported by live mast • VPC-MAX trolley, beam, and auxiliary frame installed • VPC-MAX counterweight tray installed and fully retracted • Series 1, 2, or 3 counterweight boxes installed or removed 		
Crane configured as shown in View D: <ul style="list-style-type: none"> • Live mast and fixed mast installed • Fixed mast in operating range • Boom hoist equalizer suspended from fixed mast • VPC-MAX trolley, beam, and auxiliary frame installed • Counterweight tray installed and fully retracted • Series 1, 2, or 3 counterweight boxes installed <p>Refer to the MLC300 VPC-MAX Liftcrane Mast Handling Capacities chart at the end of this section for lifting capacities with the fixed mast.</p>		

Item	Description
1	Upperworks and Lowerworks Assembled
2	VPC Trolley
3	Live Mast
4	Mast Straps
5	Self-Erect Cylinder
6	Lifting Link
7	Left-Front Side of Rotating Bed
8	CAN D Terminator
9	Dust Cap

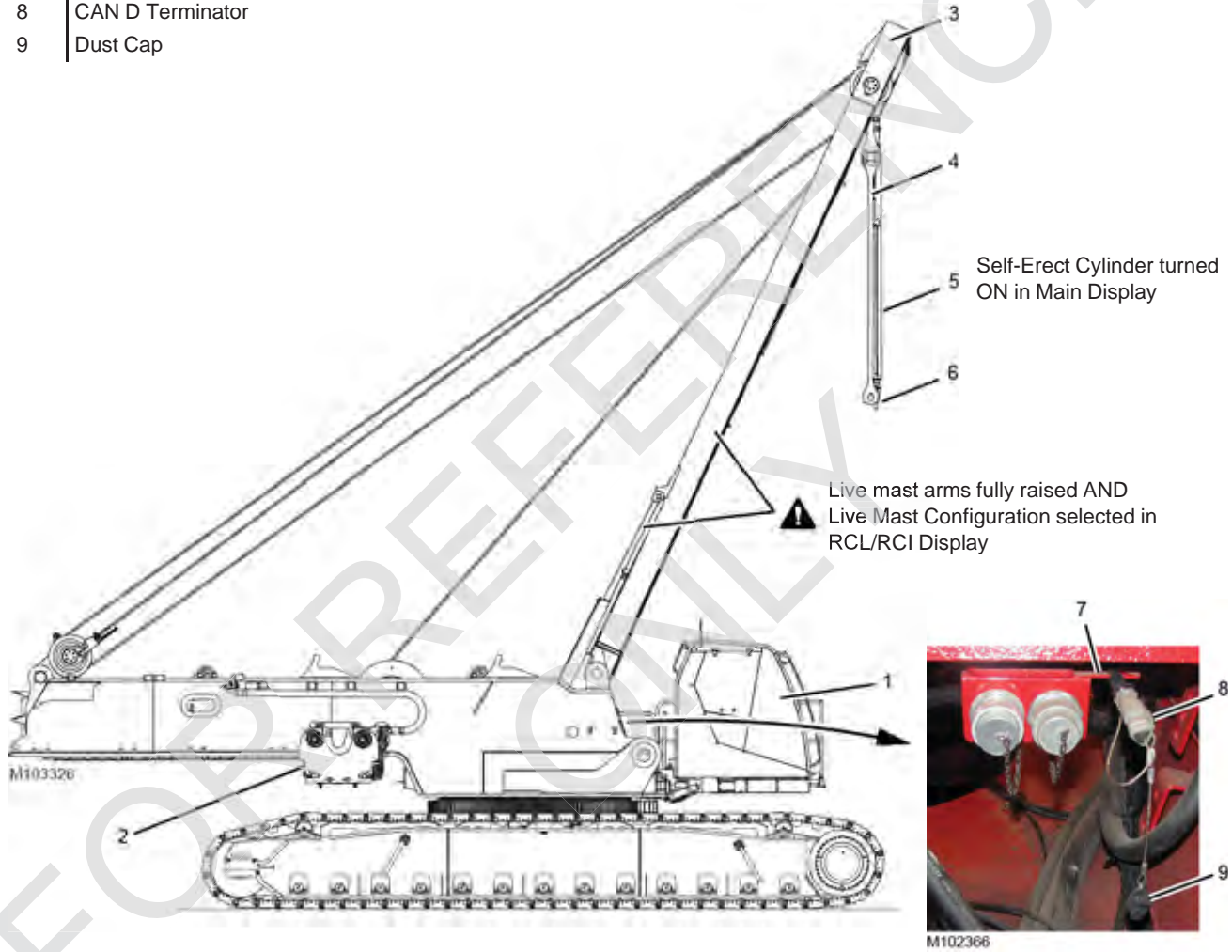

Figure 4-9

INSTALLING VPC-MAX BEAM AND TROLLEY

Prepare Crane

The MLC300 must be assembled to the extent shown in [Figure 4-9](#). Refer to Section 4 of the Crane Operator Manual for crane assembly instructions.

If your crane is already fully assembled and rigged with boom or boom and jib, proceed as follows:

- Lower the boom and jib to the ground. See Section 4 of the Crane Operator Manual or the Luffing Jib Operator Manual for lowering instructions.
- Disconnect the boom butt from the boom. See Section 4 of the Crane Operator Manual for instructions.
- Disconnect the boom butt from the crane. See Section 4 of the Crane Operator Manual for instructions.

- Remove the counterweight boxes and tray from the VPC trolley. See Section 4 of the Crane Operator Manual for instructions.
- Make sure the CAN D terminator (8) is connected to the CAN electric cable at the front of the rotating bed (7). The engine may not start and faults may be activated if this step is not performed.

Check VPC Trolley Travel Limits and Calibration

- Verify that the VPC trolley limit switches operate properly. See Section 6 of this manual for the procedure.
- Verify that the VPC trolley position is properly calibrated. See VPC Calibration Screen in the Main Display Manual for the procedure.

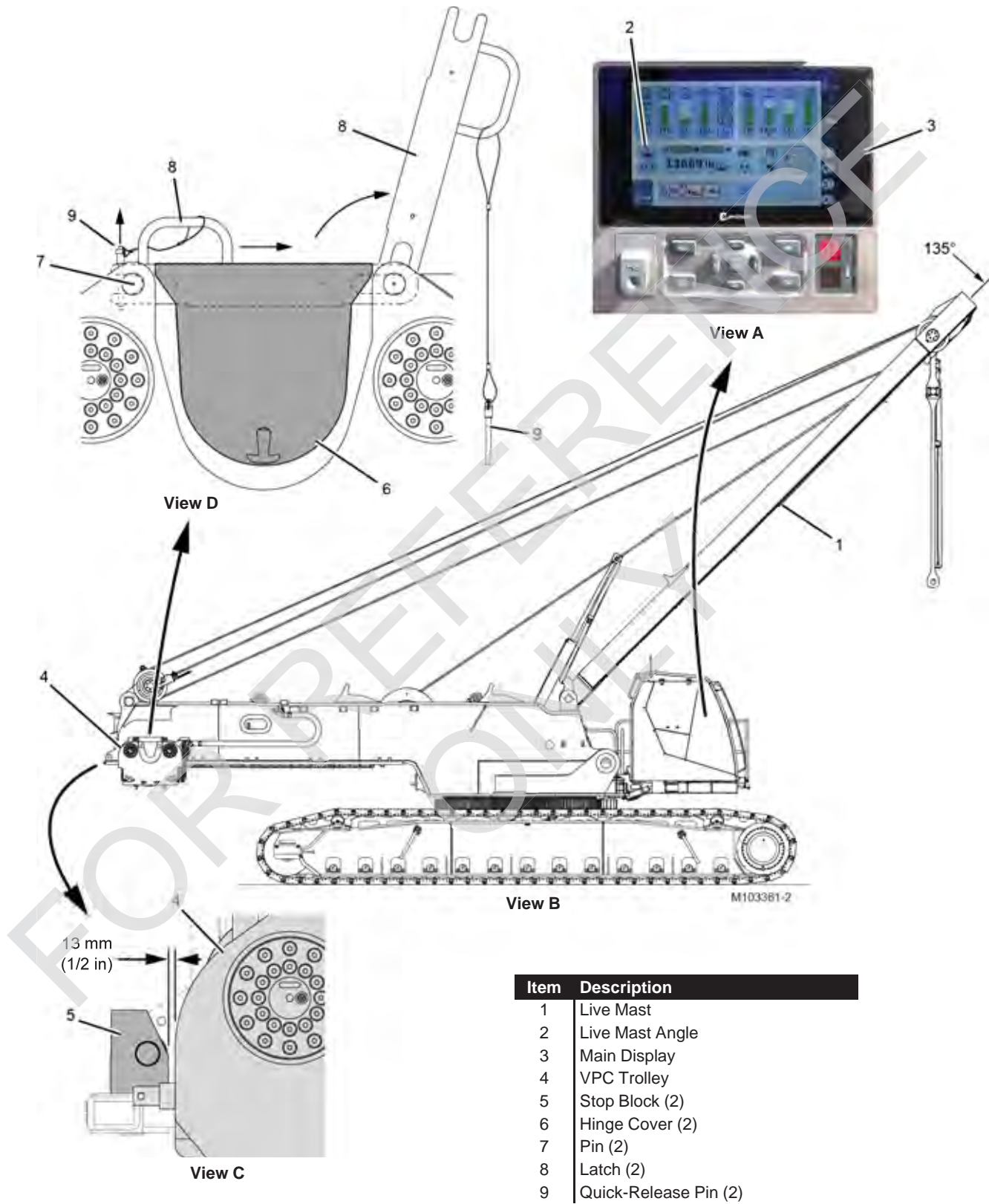

Figure 4-10

Prepare VPC Trolley

See [Figure 4-10](#) for the following procedure.

1. Position the live mast (1, View B) at 135°.

The live mast angle (2, View A) can be monitored in the Crane Status Bar of the Main Display (3) in the operator cab.
2. Using the switch on the remote control, travel the VPC trolley (4, View C) rearward until it is 13 mm (1/2 in) from the stop block (5) on each side of the rotating bed.

Take care not to allow any trolley components to contact the stop blocks.
3. Unlatch and remove the hinge covers (6, View D) from the VPC trolley (4). Store the latch covers in the parts box.
4. Remove the quick-release pins (9, View D), slide the latches (8) forward off the pins (7), and rotate the latches up and out of the way.

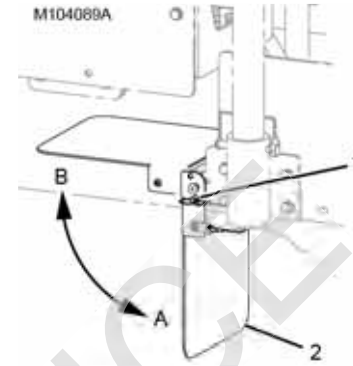

Item	Description
1	Quick-Release Pin
2	Exhaust Shield
A	Down without VPC-MAX
B	Up with VPC-MAX

Figure 4-11

Store Exhaust Shield on Crane

See [Figure 4-11](#) for the following procedure.

At the left rear ladder platform, proceed as follows:

1. Remove the quick-release pin (1).
2. Rotate the exhaust shield (2) from position (A) to position (B).
3. Install the quick-release pin (1).

NOTE If down, the exhaust shield will interfere with VPC-MAX beam installation. Leave the shield up after the beam is installed.

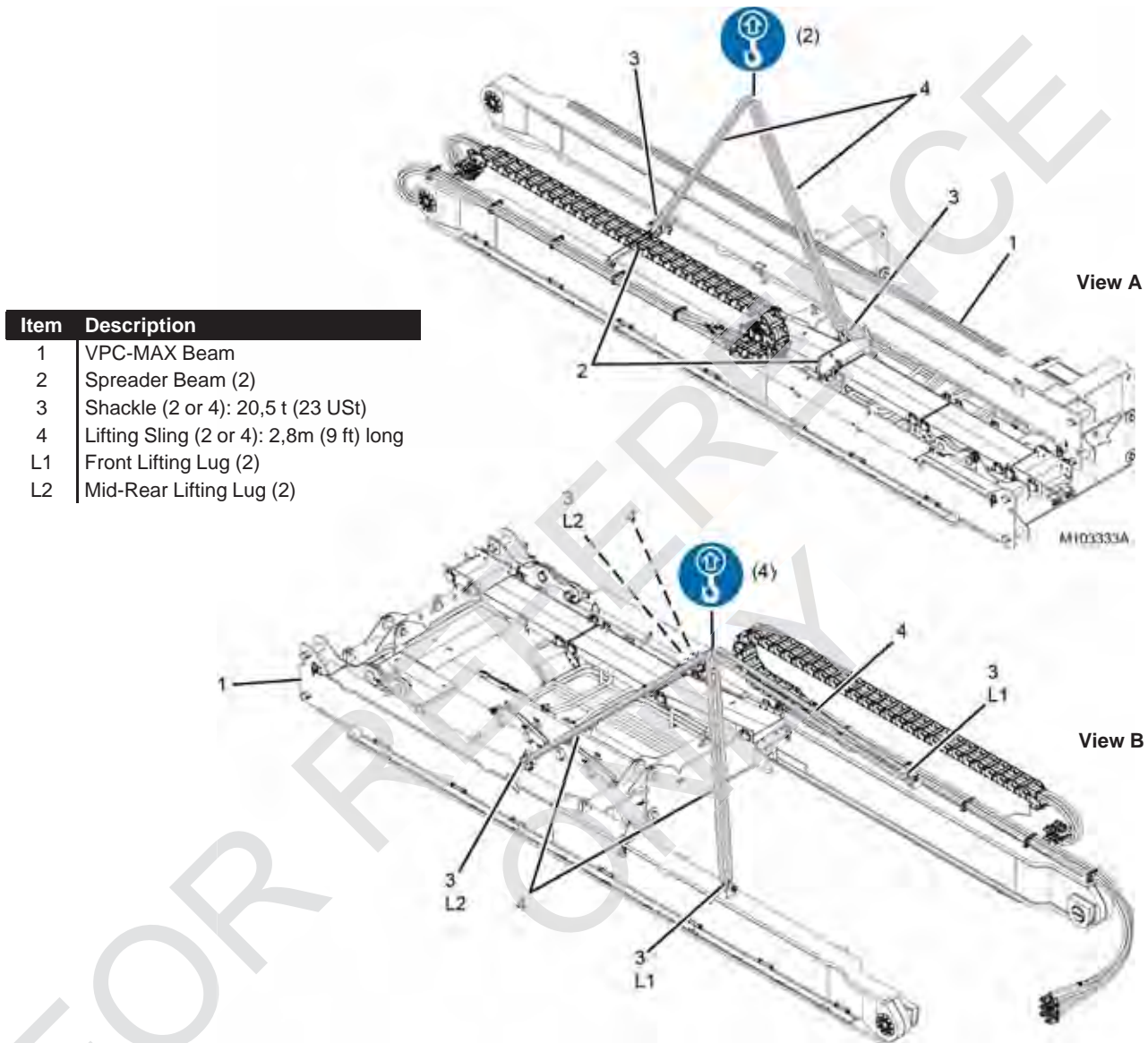

Item	Description
1	VPC-MAX Beam
2	Spreader Beam (2)
3	Shackle (2 or 4): 20,5 t (23 USt)
4	Lifting Sling (2 or 4): 2,8m (9 ft) long
L1	Front Lifting Lug (2)
L2	Mid-Rear Lifting Lug (2)

Figure 4-12

Remove VPC-MAX Beam from Trailer

The VPC-MAX beam (1) can be shipped two ways as shown in [Figure 4-12](#):

- Folded (View A)
- Unfolded (View B)

See [Figure 4-12](#) for the following procedure.

1. If the beam is folded, connect two shackles (3, View A) and two lifting slings (4) to the spreader beams (2).
2. If the VPC-MAX beam is unfolded, connect four shackles (3, View B) and four lifting slings (4) to the lifting lugs (L1 and L2) on the VPC-MAX beam.
3. Connect the other end of the lifting slings to the hook of the assist crane.
4. Remove the tie-downs and blocking securing the VPC-MAX beam to the trailer.
5. Lift the VPC-MAX beam off the trailer and remove the trailer.
6. Place the VPC-MAX beam on blocking at the rear of the MLC300.

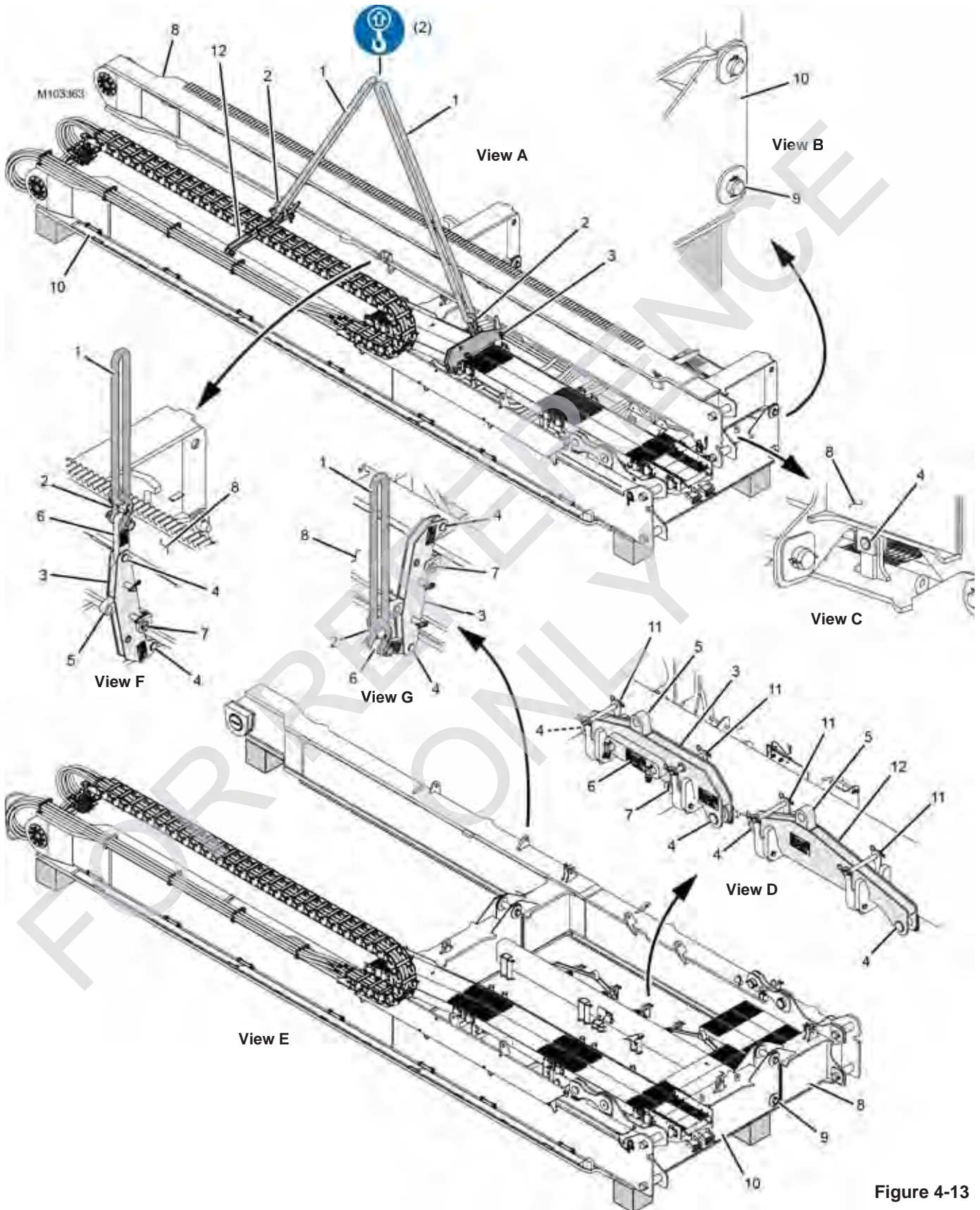

Figure 4-13

Legend for [Figure 4-13](#).

Item	Description
1	Lifting Sling (2): 2,8 m (9 ft) long
2	Shackle (2): 20,5 t (23 USt)
3	Rear Spreader Beam – 40 kg (88 lb)
4	Pin with Safety Pin (6)
5	Lifting Lug
6	Lifting Link
7	Pin with Safety Pin
8	Right-Hand Beam
9	Pin with Retaining Pin and Cotter Pins
10	Left-Hand Beam
11	Pin with Hair-Pin Cotters (4)
12	Front Spreader Beam – 21 kg (46 lb)

Unfold VPC-MAX Beam

See [Figure 4-13](#) for the following procedure.

1. Unpin and remove the rear and front spreader beams (3 and 12, View A) using the existing lifting slings (1) shackles (2).
2. Place the front spreader beam to side until later.
3. Place the rear spreader beam (3) on the suitable work surface and prepare it as follows (see View F):
 - a. Disconnect the lifting sling (1) and shackle (2) from the lifting lug (5) on the spreader beam.
 - b. Remove the lifting link (6) from storage on the spreader beam.
4. Remove the bottom pins (9, View B, 2 places) from the left-hand beam (10).
5. Hoist with the assist crane until the lifting sling (1, View F) is tight and remove pins (4, View C, 2 places).
6. Using the assist crane, slowly lift and rotate the right-hand beam (8, View A) from the shipping position to the working position (Views E and G).
7. Install the bottom pins (9, View E, 2 places) to connect the right-hand beam (8) to the left-hand beam (10).
8. Block under the right-hand beam as required.
9. Unpin and remove the rear spreader beam (3, View G) from the lifting lugs on the right-hand beam (8).
10. Store the rear spreader beam as shown in View D.
11. Store the lifting link (6, View D) on the rear spreader beam (3).
12. Store the front spreader beam (12) as shown in View D.
13. Store the pins (4, View C, 2 places) in the lugs on the right-hand beam (8).

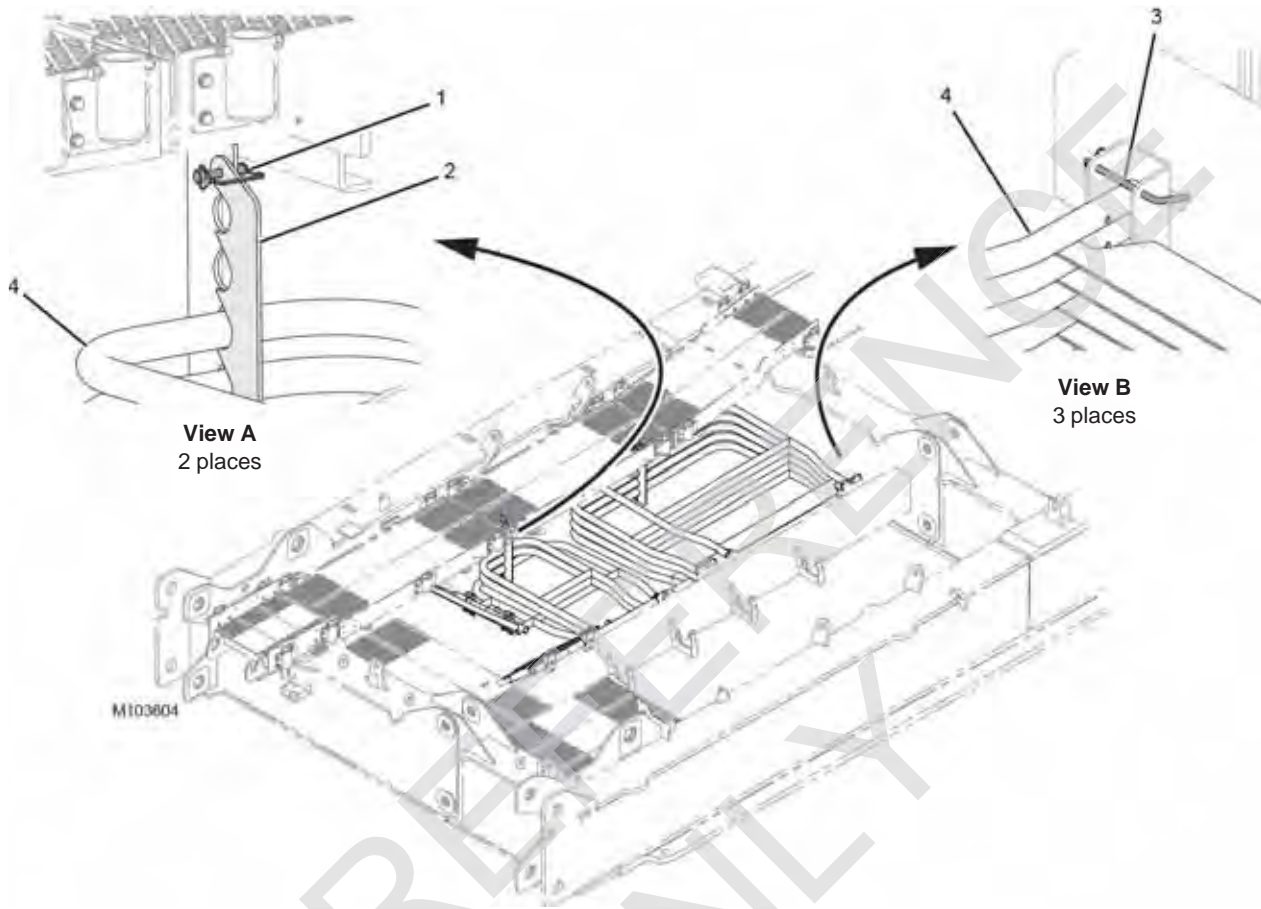

M103804

Item	Description
1	Safety Pin (2)
2	Bracket (2)
3	Hitch Pin with Hair-Pin Cotter (3)

Figure 4-14

Remove Handrails from VPC-MAX Beam

If the VPC-Max Beam was shipped folded, perform the following procedure after the beam is unfolded.

See [Figure 4-14](#) for the following procedure.

1. Remove the safety pins (1, View A) and lower the brackets (2).
2. Remove the hitch pins (3).
3. Lift the handrails (4) out of the VPC-MAX beam and place the handrails to the side for installation later.
The heaviest handrail weighs 10 kg (22 lb).
4. Close the brackets (2, View A) and reinstall the safety pins (1).
5. Reinstall the hitch pins (3, View B).

FOR REFERENCE ONLY

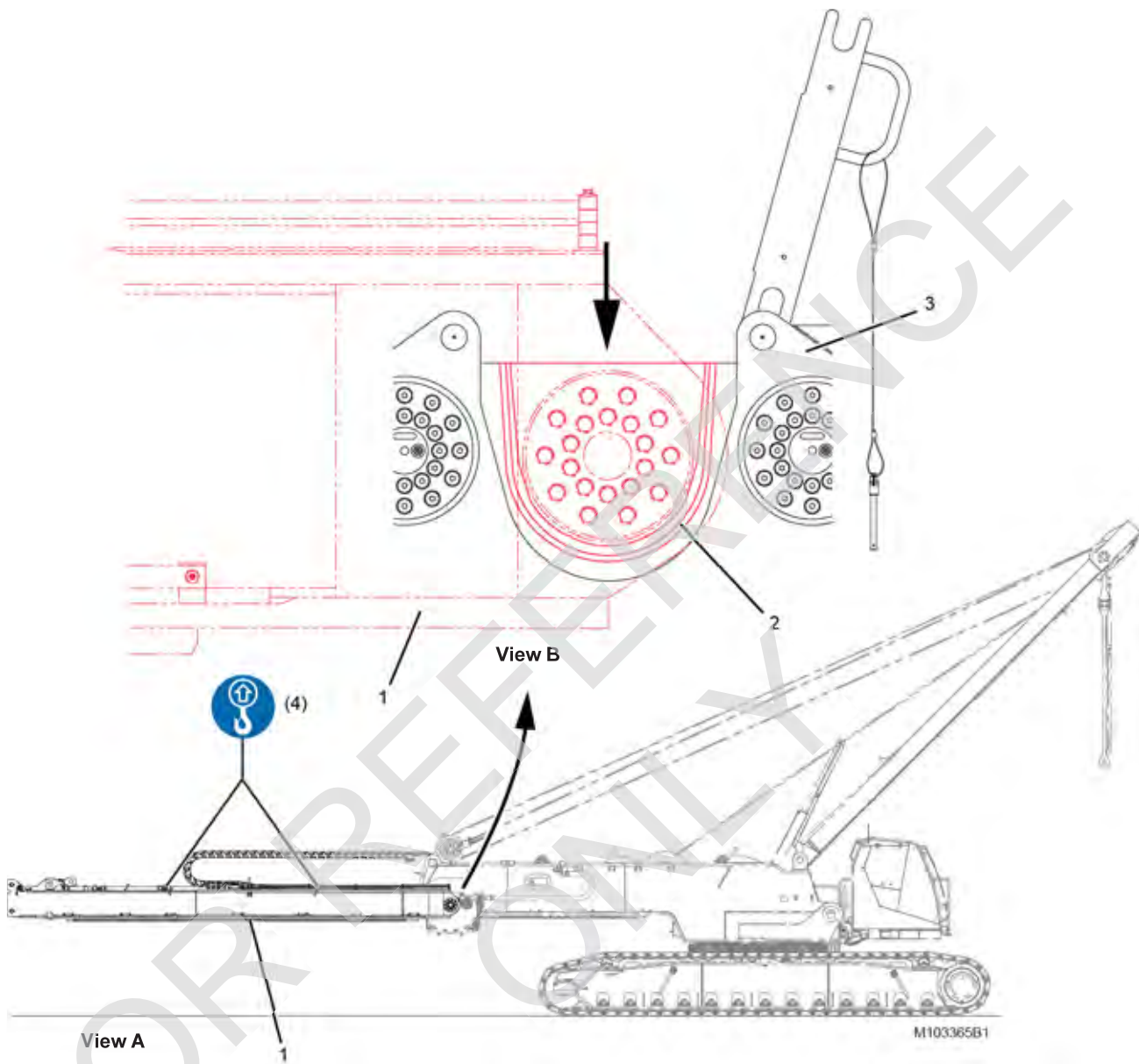

Item	Description
1	VPC-MAX Beam
2	Spherical Bearing Carrier (2)
3	VPC Trolley
4	Blocking
5	Latch (2)
6	Pin (2)
7	Quick-Release Pin (2)

Figure 4-15

Attach VPC-MAX Beam to VPC Trolley

1. Connect four shackles and four lifting slings to the lifting lugs (L1 and L2, View B, [Figure 4-12 on page 4-16](#)) on the beam and to the hook of the assist crane.

See [Figure 4-15](#) for the following steps.

2. Lift the VPC-MAX beam (1, View A) into position at the rear of the crane.

3. Guide the spherical bearing carriers (2, View B) into the VPC trolley (3) saddles.
4. Lower the rear of VPC-MAX beam (1, View C) onto 305 mm (12 in) high blocking (4).
5. Disconnect the front two shackles and slings from the beam.
6. Lower the latches (5, View D) so they engage the pins (6) and install the quick-release pins (7).

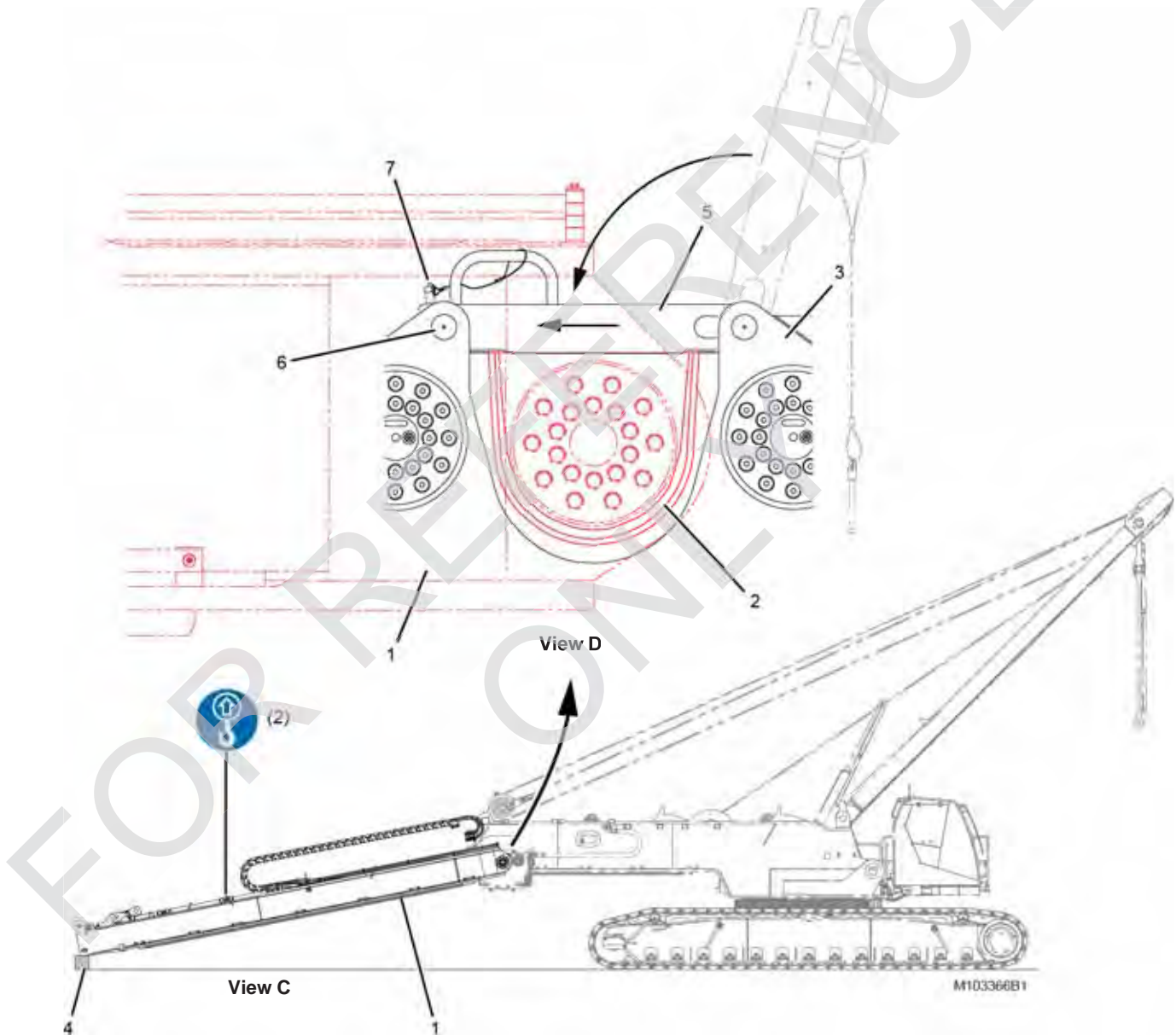
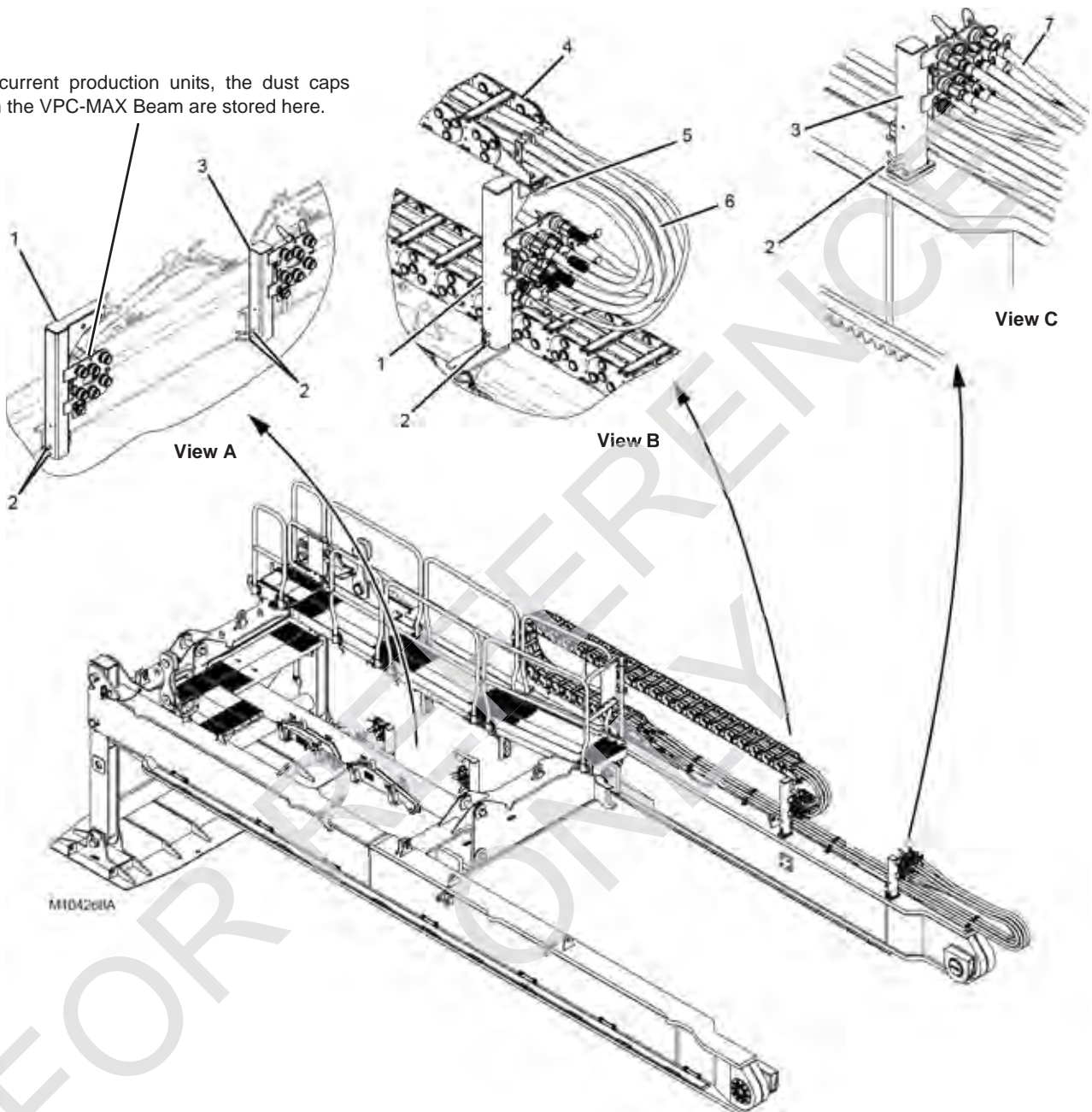

Figure 4-15 continued

On current production units, the dust caps from the VPC-MAX Beam are stored here.



Item	Description
1	Hose/Cable Storage Bracket (energy chain) 15 kg (33 lb)
2	Hitch pin with Hair-Pin Cotter (4)
3	Hose/Cable Storage Bracket (VPC-MAX) 11 kg (24 lb)
4	Energy Chain
5	Hitch pin with Hair-Pin Cotter (2)
6	Hydraulic Hoses and Electric Cable (energy chain)
7	Hydraulic Hoses and Electric Cable (VPC-MAX)

Figure 4-16

FOR REFERENCE ONLY

THIS PAGE INTENTIONALLY LEFT BLANK

Item	Description
1	Shorting Plug with Dust Cap
2	Electric Cable (WVT1E)
3	VPC Trolley
4	Electric Cable with Dust Cap (WVB3)
5	VPC-MAX Beam (left-hand)
6	Hydraulic Nipple
7	Bulkhead
8	Coupler (6)
9	Hydraulic Hose (6)

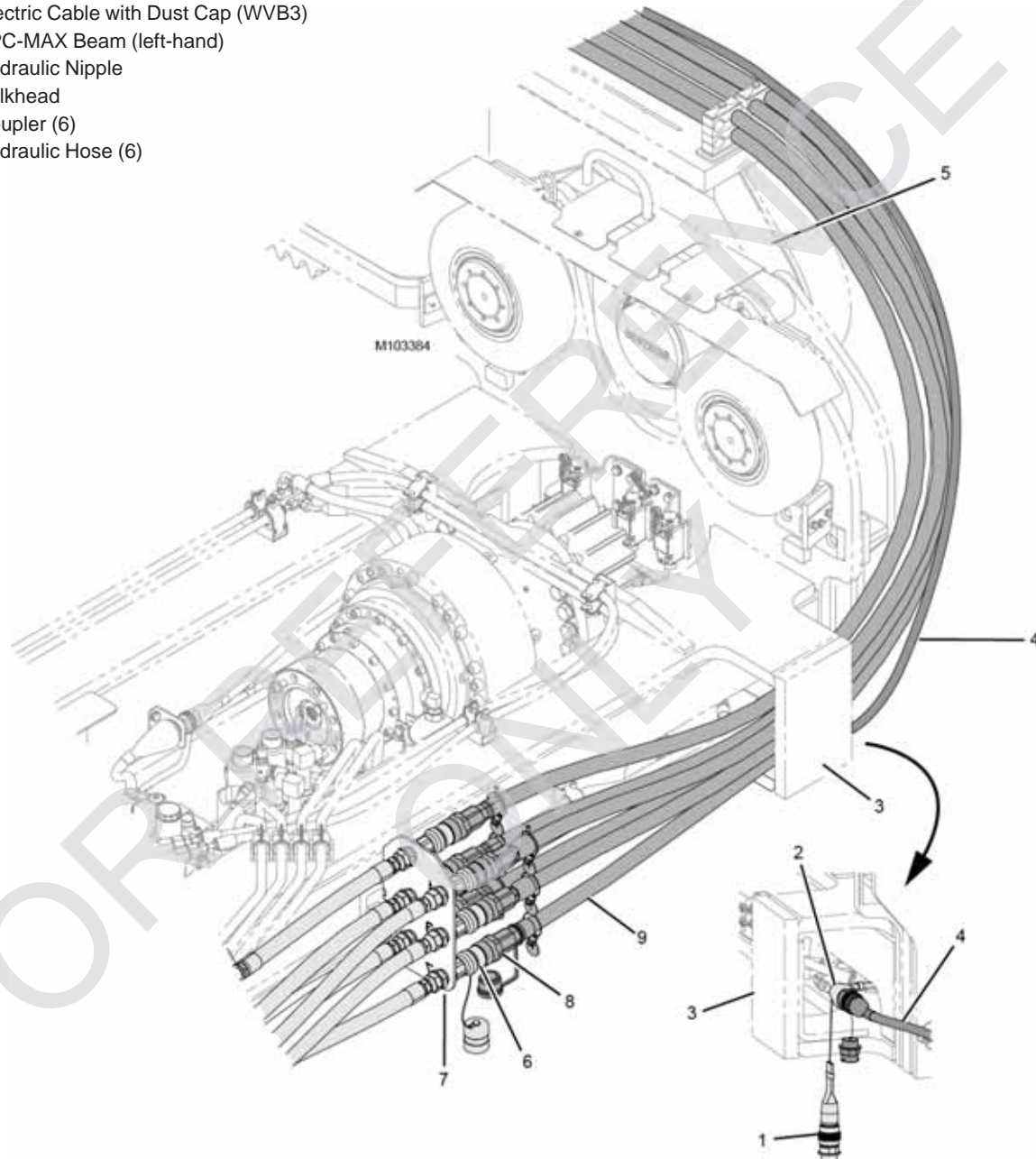

Figure 4-17

NOTE Current production cranes are equipped with the hose/cable storage brackets shown in [Figure 4-16 on page 4-24](#).

On current production cranes, disconnect the hydraulic hoses and electric cable from the storage bracket (3, View C, [Figure 4-16 on page 4-24](#)). Then, remove and store the storage bracket (3) as shown in View A.

Connect VPC-MAX Beam-to-VPC Trolley Electric Cable

1. Disconnect the shorting plug (1) from the electric cable (2).
2. Thoroughly clean the corresponding dust cap and connect it to the shorting plug (1).
3. Tuck the shorting plug into the VPC trolley (3) opening so the shorting plug cannot be damaged.
4. Disconnect the dust cap from the end of the electric cable (4) from the VPC-MAX beam (5).
5. Thoroughly clean the electric cable ends.
6. Connect the electric cable (4) to the electric cable (2).

Connect VPC-MAX Beam-to-VPC Trolley Hydraulic Hoses

1. Disconnect the dust caps from the hydraulic nipples (6) on the bulkhead (7) at the VPC trolley (3).
2. Disconnect the dust caps from the couplers (8) on the ends of the hydraulic hoses (9).
3. Thoroughly clean and lubricate the hydraulic nipples and couplers.
4. Route the hydraulic hoses (9) from the VPC-MAX beam (5) to the VPC trolley (3) as shown and connect the hydraulic hose couplers to the hydraulic nipples on the bulkhead.
 - Match the identification numbers on the hydraulic hoses with the numbers stamped into the bulkhead.
 - Connect the mating dust caps together as the hydraulic hoses are connected.

Item	Description
1	VPC-MAX Beam
2	VPC Trolley
3	Stop Block (2)
4	Rotating Bed
5	50 mm (2 in)
6	Hook (2)
7	Pin

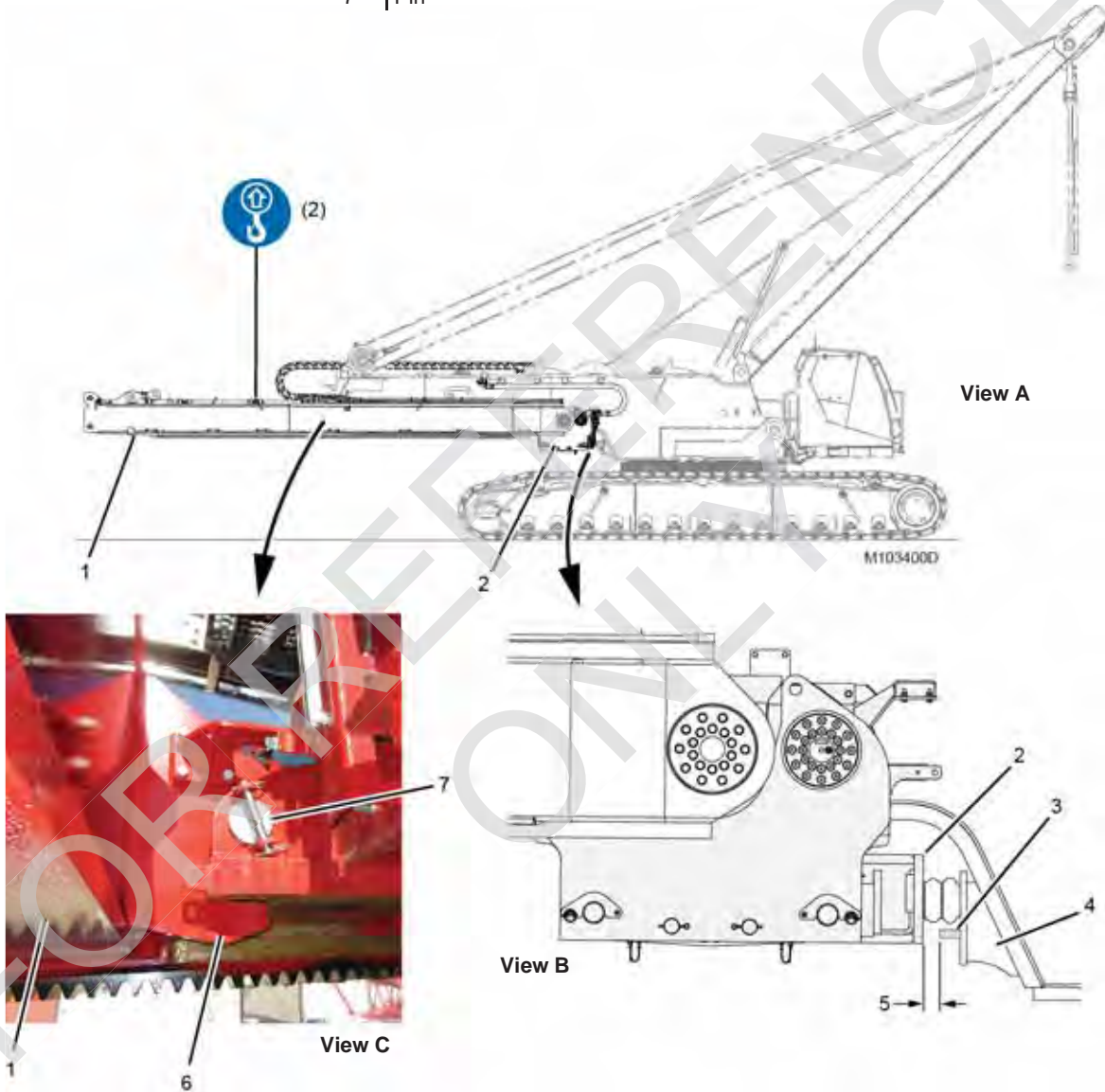

Figure 4-18

Hook VPC-MAX Beam to Rotating Bed

See [Figure 4-18](#) for the following steps.

1. Lift the rear of the VPC-MAX beam (1, View A) to horizontal with the assist crane.
2. Follow with the assist crane during [step 3](#).
3. Using the switch on the remote control, travel the VPC trolley (2, View B) forward until the distance (5) between the VPC trolley (2) and the stop block (3) on both sides of the rotating bed (4) is 50 mm (2 in).

The hooks (6, View C) on the VPC-MAX beam (1) should now be engaged with the pins (7) on the rear of the rotating bed.

4. Adjust the VPC-MAX beam-on-hook limit switches. See Section 6 of this manual for the procedure.
5. Lower the VPC-MAX beam (1, View C) with the assist crane until the hooks (6) are resting on the pins (7).
6. Disconnect the shackles and lifting slings from the VPC-MAX beam.

FOR REFERENCE ONLY

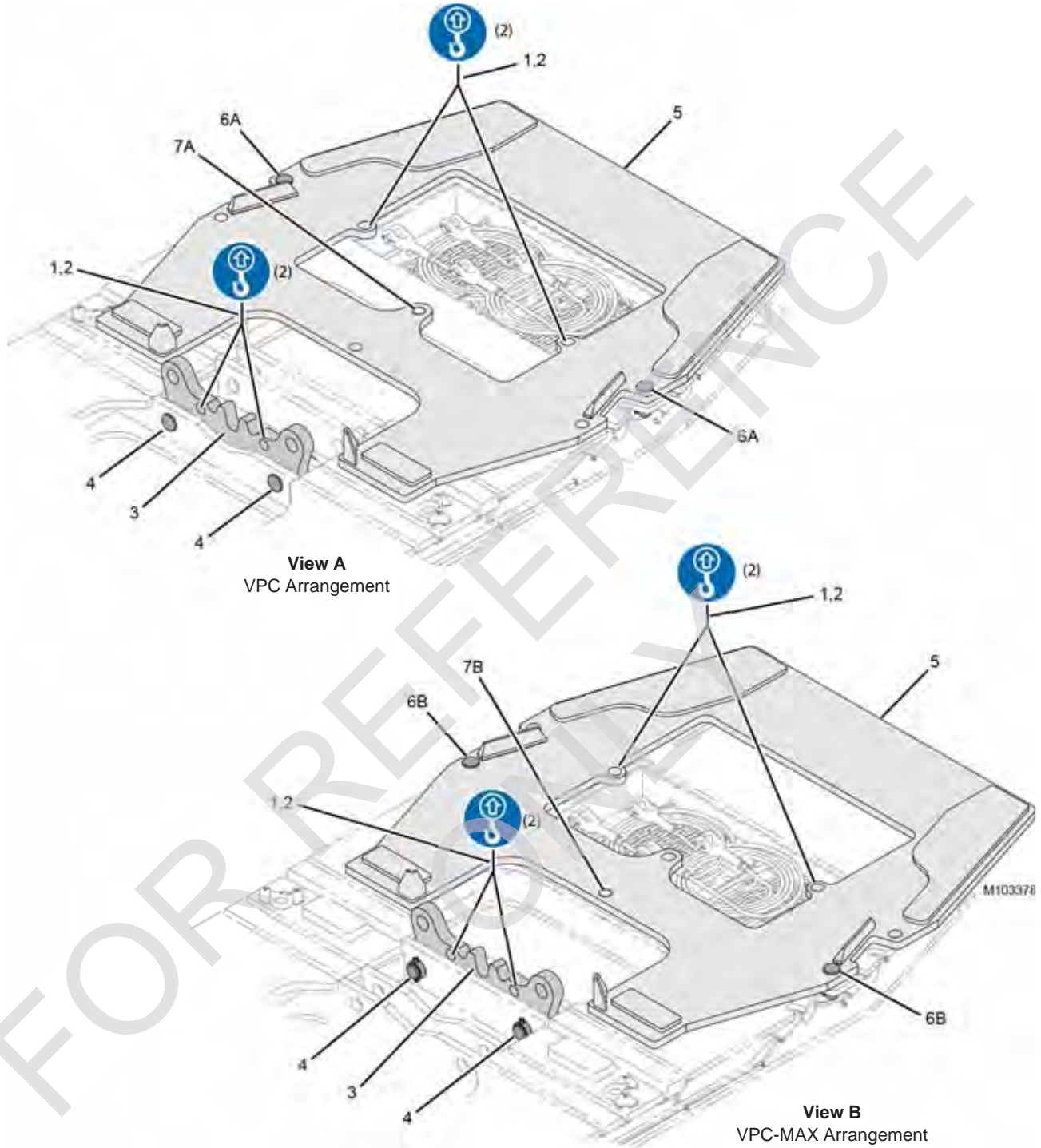

Item	Description	Item	Description
1	Shackle (2): 20,5 t (23 USt)	6	Pin with Cotter Pin (4)
2	Lifting Sling (2): 2,8m (9 ft) long	7	Pin with Cotter Pin (2)
3	Mounting Frame (2)	A	Frame Holes for VPC
4	Pin with Collar, Retaining Pin and Cotter Pins (4)	B	Frame Holes for VPC-MAX
5	Counterweight Tray Frame (2)		

Figure 4-19

Remove Counterweight Tray from Trailer

See [Figure 4-20](#) for the following procedure.

1. Remove the tie-downs and blocking securing the counterweight tray (2) to the trailer (1).
2. Connect the shackles (3) and lifting slings (4) to the lifting lugs (5) on the counterweight tray and to the hook of the assist crane.
3. Lift the counterweight tray clear of the trailer and remove the trailer.
4. Place the counterweight tray on blocking in the assembly area.
5. Disconnect the lifting slings.

Prepare Counterweight Tray

Perform the following steps if needed. See [Figure 4-19](#).

1. Connect two shackles (1, View A) and two lifting slings (2) to the inboard holes in the mounting frame (3) and to the assist crane.
2. Tighten the lifting slings and remove pins (4, View A).
3. Lift the mounting frame (3) from the VPC position (View A) to the VPC-MAX position (View B).
4. Align the connecting holes and install pins (4, View B). Make sure the collars are oriented as shown.
5. Disconnect the shackles (1) from the mounting frame (3).
6. Repeat [step 1](#) through [step 5](#) for the other mounting frame.
7. Connect two shackles (1, View A) and two lifting slings (2) to the lifting holes in the counterweight tray frame (5).
8. Tighten the lifting slings and remove the pins (6 and 7, View A) from holes **A**.
9. Lift the counterweight tray frame (5) from the VPC position (View A) to the VPC-MAX position (View B).
10. Align the connecting holes and install the pins (6 and 7, View B) in holes **B**.
11. Disconnect the shackles (1) from the counterweight tray frame (5).
12. Repeat [step 7](#) through [step 11](#) for the other mounting frame.

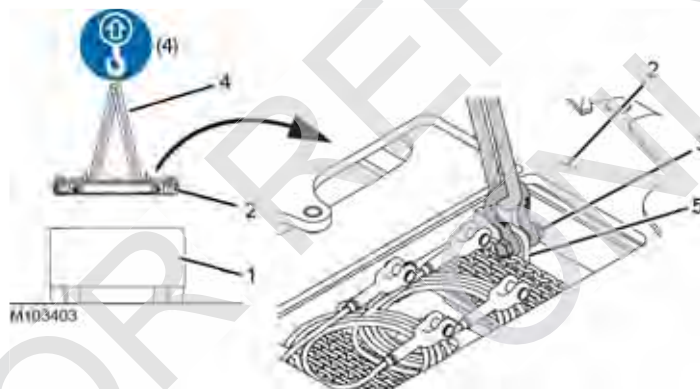

Item	Description
1	Trailer
2	Counterweight Tray
3	Shackle (4): 20,5 t (23 USt)
4	Lifting Sling (4): 2,8m (9 ft) long
5	Lifting Lug (4)

Figure 4-20

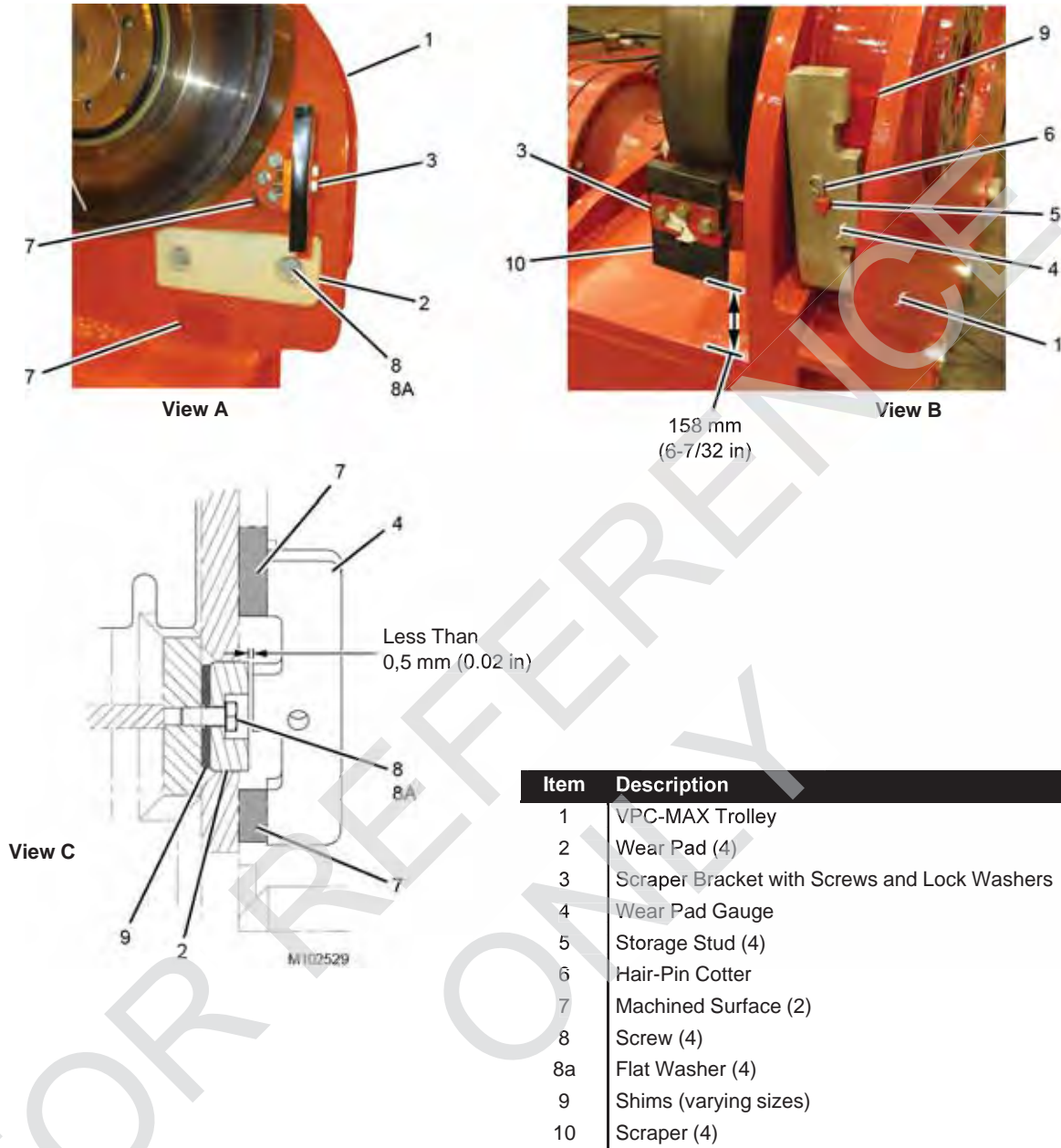
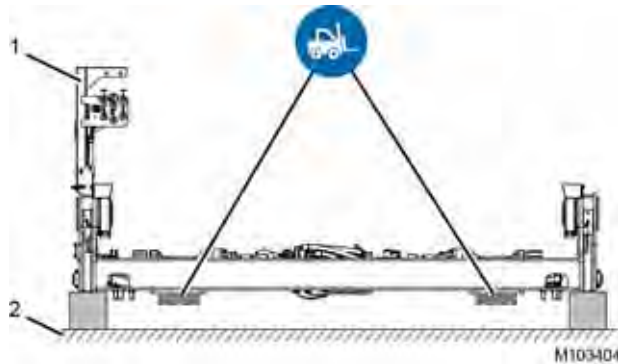

Figure 4-21



Item	Description
1	VPC-MAX Trolley
2	Trailer

Figure 4-22

Remove VPC-MAX Trolley from Trailer

See [Figure 4-22](#) for the following procedure.

1. Remove the tie-downs and blocking securing the VPC-MAX trolley (1) to the trailer (2).
2. Position the forks from a forklift under the VPC-MAX trolley at the locations shown.
3. Lift the VPC-MAX trolley clear of the trailer and remove the trailer.
4. Place the VPC-MAX trolley on blocking in the assembly area.
5. Remove the forklift.

Adjust VPC-MAX Trolley Wear Pads

See [Figure 4-21](#) for the following procedure.

Prior to each installation of the VPC-MAX trolley, inspect and, if needed, adjust the VPC-MAX trolley wear pads (2, View A) using either **Primary Method** or the **Alternative Method**.

NOTE The VPC-MAX trolley must be removed from the crane and the wear pads inspected at least yearly.

1. Remove the scraper bracket (3, View A) at each wear pad (2).
2. Remove the wear pad gauge (4, View B) from the storage stud (5).
3. Hold the wear pad gauge (4, View C) against the machined surfaces (7) adjacent to each wear pad (2).
4. The clearance between the wear pad gauge (4, View C) and the wear pad (2) must be less than 0,5 mm (0.02 in).
5. If necessary, remove the screws (8, View C) and the flat washers (8A) and install shims (9) between the VPC-MAX trolley (1) and the wear pad (2).
6. The shims (9, View B) are stored on the storage stud (5) at four locations.
7. Repeat the steps until you have the proper clearance at each wear pad.
8. Install and securely tighten the flat washers (8A, View C) and the screws (8).
9. Reinstall the wear pad gauge (4, View B) on the storage stud (5).
10. Reinstall the hair-pin cotter (6, View B) on each storage stud.
11. Reinstall the scraper bracket (3, View A) at each wear pad (2).

Adjust VPC-MAX Trolley Scrapers

See [Figure 4-21](#) for the following procedure.

Adjust each scraper (10, View B), as follows:

- a. Loosen the three bolts securing the scraper (10) to the scraper bracket (3).
- b. Adjust the scraper (up or down) so the distance between the scraper (10) and the VPC-MAX trolley (1) is 158 mm (6-7/32 in).
- c. Securely tighten the nuts on the bolts to secure the position of the scraper.

Item	Description
1	Trolley Installation Guide (2)
2	Hair-Pin Cotter (4)
3	Stop Block (2)
4	VPC-MAX Beam
5	Trolley Rail (2)

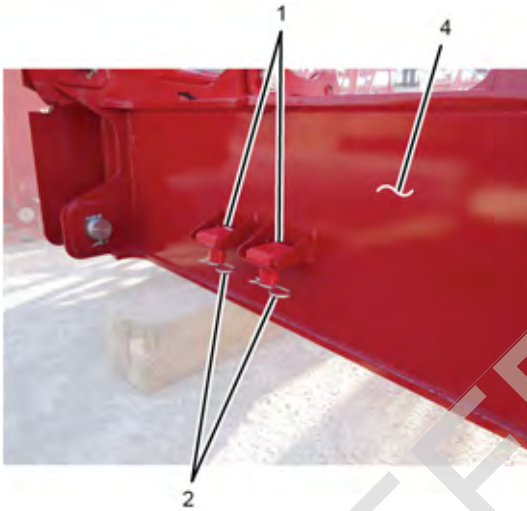

View A — STORED

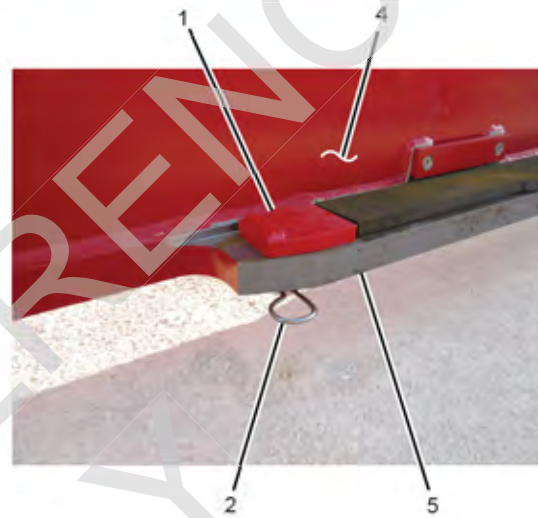

View C — WORKING

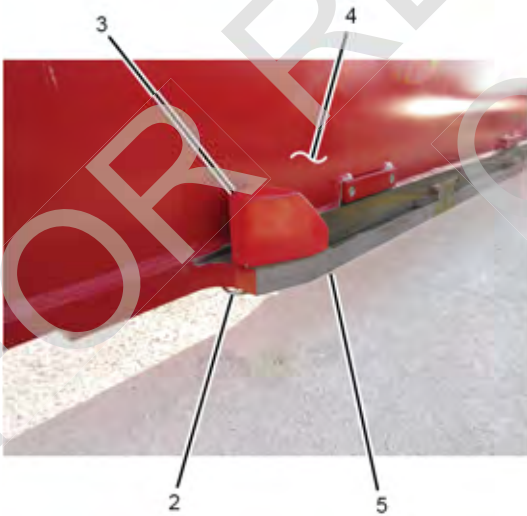

View B — WORKING

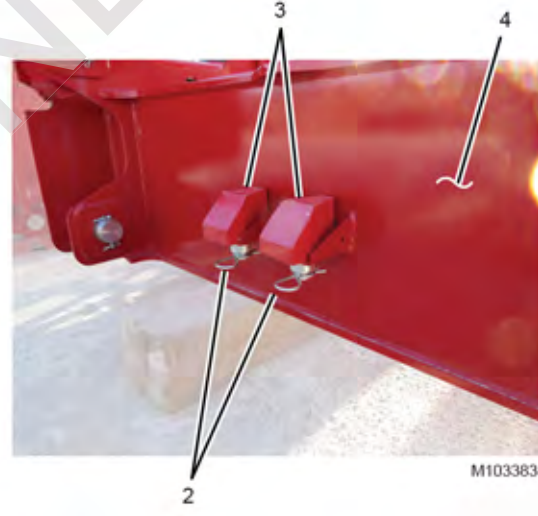

View D — STORED

M103383

Figure 4-23

Install Trolley Installation Guides

See [Figure 4-23](#) for the following procedure.

1. Remove the trolley installation guides (1, View A) from the storage position on the rear of the VPC-MAX beam (4).
2. Remove the stop blocks (3, View B) from the working position on the trolley rails (5).
3. Install the trolley installation guides (1, View C) in the working position on the trolley rails (5).
4. Secure the trolley installation guides with the hair-pin cotters (2).
5. Install the stop blocks (3, View D) in the storage position on the rear of the VPC-MAX beam (4).
6. Secure the stop blocks with the hair-pin cotters (2).



WARNING

Falling Load Hazard!

The trolley installation guides must be installed in the working position to prevent the VPC-MAX trolley and counterweight tray from rolling off the trolley rails when the lifting slings are disconnected.

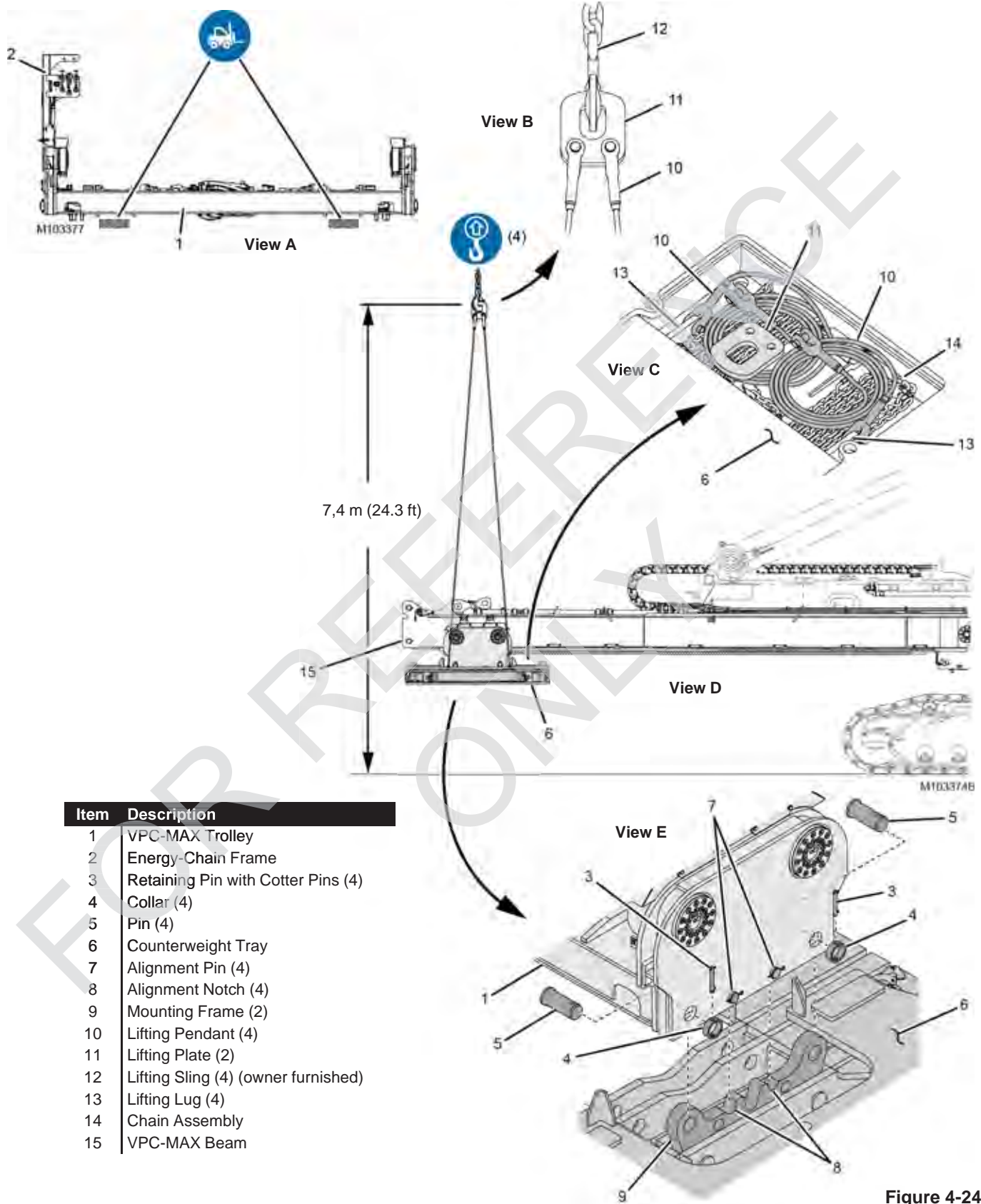

Figure 4-24

Attach VPC-MAX Trolley to Counterweight Tray

See [Figure 4-24](#) for the following procedure.

1. Position the forks from a forklift under the VPC-MAX trolley (1, View A) at the locations shown.

The energy-chain frame (2) must be toward the forklift operator's left side.

2. Remove the retaining pins (3, View E), the collars (4), and the pins (5) from the VPC-MAX trolley (1).
3. Slowly lift the VPC-MAX trolley (1, View E) into position over the counterweight tray (6) so the alignment pins (7) in the trolley engage the alignment notches (8) in the mounting frames (9).

NOTE The counterweight tray is symmetrical. Therefore, the trolley can be installed from either end of the tray.

4. Align the mounting holes and install the pins (5, View E), the collars (4), and retaining pins (3).
5. Remove the forklift.

NOTE Manitowoc provides two lifting pendants (10, View C), a lifting plate (11), and two lifting lugs (13) on each side of the tray.

6. Attach four lifting pendants (10, View B) to the lifting slings (12) from the assist crane with the lifting plates (11).
7. Attach the other end of the lifting pendants (10, View C) to the lifting lugs (13) in the counterweight tray (6).
8. Remove the counterweight chain assemblies (14, View C) from the storage pockets in the counterweight tray and place chains to the side for future use.
9. Attach hand-held taglines to the lugs on the rear corners of the tray. Have ground personnel control swinging of the tray with the taglines.

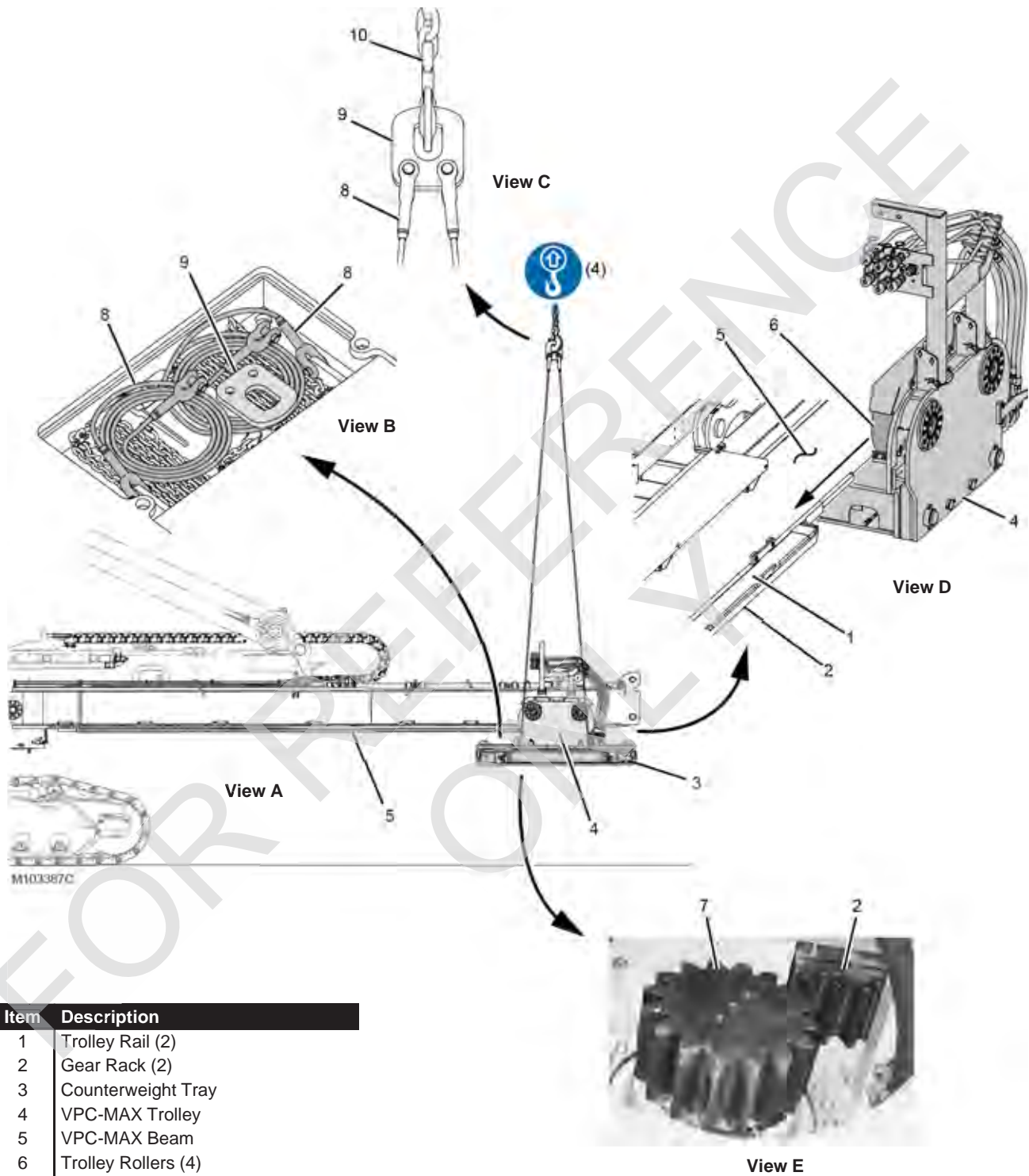

Item	Description
1	Trolley Rail (2)
2	Gear Rack (2)
3	Counterweight Tray
4	VPC-MAX Trolley
5	VPC-MAX Beam
6	Trolley Rollers (4)
7	Drive Pinion
8	Lifting Pendant (4)
9	Lifting Plate (2)
10	Lifting Sling (4) (owner furnished)

Figure 4-25

Install VPC-MAX Trolley and Counterweight Tray

See [Figure 4-25](#) for the following procedure.

1. Make sure the trolley rail (1, View D) and gear rack (2) on both sides of the rotating bed are clean and free of debris.
2. Lift the counterweight tray (3, View A) and VPC-MAX trolley (4) into position at the rear of the VPC-MAX beam (5).
3. Position the VPC-MAX trolley (4, View D) so the trolley rollers (6) engage the top of the trolley rail (1) on both sides of the rotating bed.
4. From under the VPC-MAX trolley, remove the access guard from over the drive pinion (7, View E) on both sides of the VPC-MAX trolley.
5. Guide the trolley onto the rails with the assist crane until the teeth of both drive pinions (7, View E) are nearly in contact with the teeth of both gear racks (2) on the underside of the VPC-MAX beam.

The pinions and gear racks can be viewed through the access holes in the bottom of the VPC-MAX trolley.



WARNING

Falling Load Hazard!

To prevent the VPC-MAX trolley from rolling off the trolley rails, do not disconnect the assist crane from the VPC-MAX trolley until after the trolley pinions are engaged with the gear rack and the stop blocks are installed in [step 10](#).

6. Perform the following procedures:
 - ["Connect VPC-MAX Energy Chain to VPC-MAX Trolley" on page 4-41](#)
 - ["Connect VPC-MAX Trolley Electric Cables" on page 4-41](#)
7. Make sure the drive pinions (7, View E, [Figure 4-25](#)) are not engaged with the gear rack teeth and perform the following steps:
 - Make sure the trolley rollers are bearing the weight of the trolley on the rails. The lifting slings should be just slack. This will prevent gear backlash problems.
 - Using the remote control, rotate the drive pinions in the forward direction. The gear teeth on both drive pinions should be rotating rearward when looking through the access holes. If necessary, correct the hydraulic piping connections.
 - Using the assist crane, move the trolley forward to engage the gear teeth. Make sure the tip of a gear tooth on the pinion does not contact the tip of gear tooth on the gear rack. Damage could occur.
8. While following with the assist crane, use the remote control to drive the VPC-MAX trolley forward until the drive pinions (7, View E) are fully engaged with the gear rack (2) and there is enough room at the rear of the beam to install the stop blocks.
9. Remove and store the trolley installation guide (Views A and C, [Figure 4-23 on page 4-34](#)).
10. Install the stop blocks on the rear of the VPC-MAX beam (View B, [Figure 4-23 on page 4-34](#)).
11. Lower the lifting pendants (8, View C, [Figure 4-25](#)) until they are slack.
12. Disconnect the lifting pendants (8, View C) and the lifting plates (9) from the assist crane slings (10).
13. Coil the lifting pendants (8, View B) into the storage pockets in the tray.
14. Place the lifting plates (9, View B) into the storage pockets in the tray.
15. Reinstall the covers over the access holes in the bottom of the VPC-MAX trolley.

Item	Description	Item	Description
1	Energy Chain	7	Electric Cable
2	VPC-MAX Beam	8	Electric Cable
3	Energy Chain Frame	9	Counterweight Tray
3a	Hitch Pin with Hair-Pin Cotter (2)	10	VPC-MAX Trolley
4	Hitch Pin with Hair-Pin Cotter (2)	11	Bulkhead
5	Shorting Plug with Dust Cap	12	Hydraulic Hose (6)
6	Receptacle		

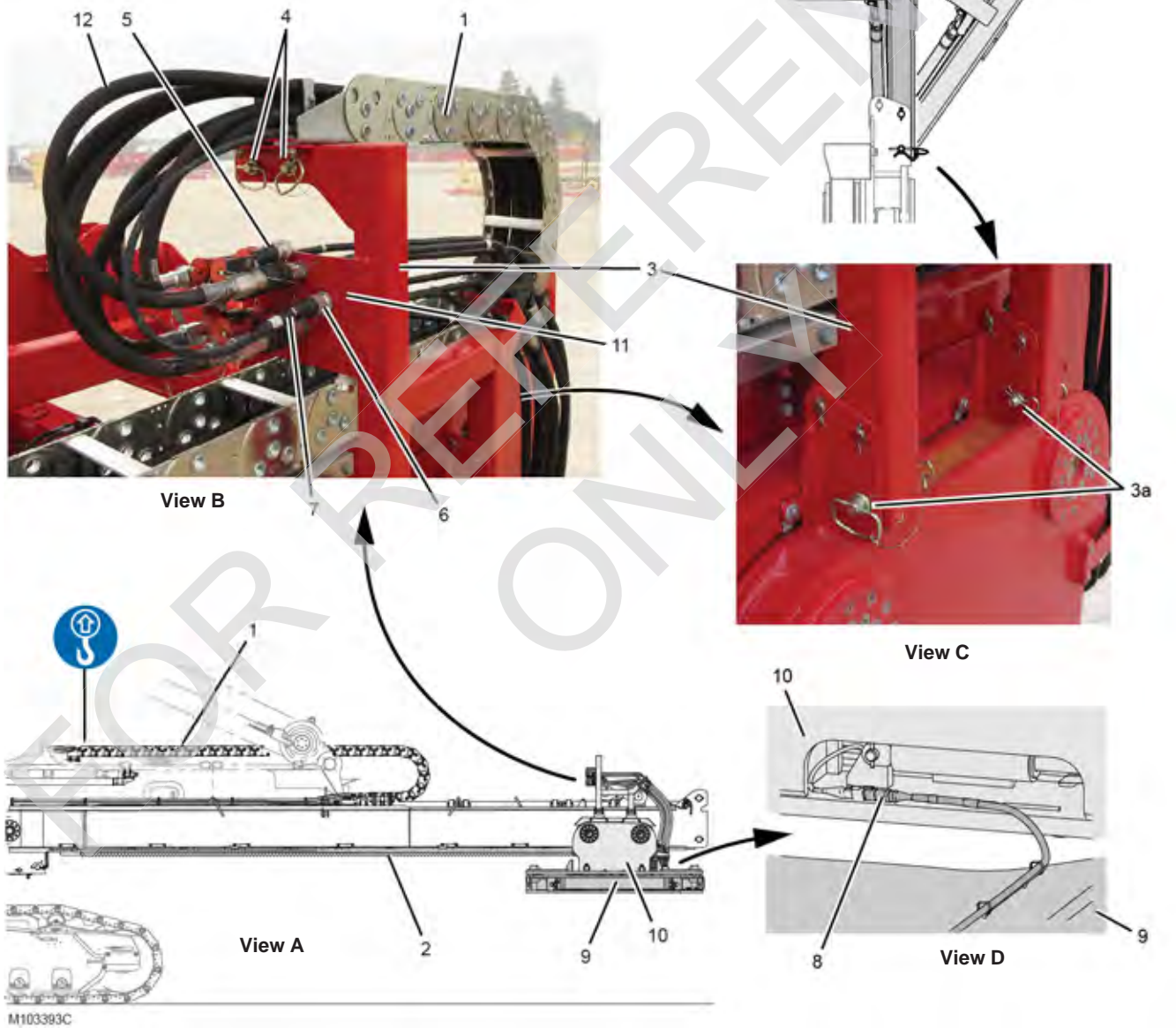

Figure 4-26

Connect VPC-MAX Energy Chain to VPC-MAX Trolley

NOTE Current production cranes are equipped with the hose/cable storage brackets shown in [Figure 4-16 on page 4-24](#).

On current production cranes:

- Disconnect the hydraulic hoses and electric cable from the storage bracket (1, View B, [Figure 4-16 on page 4-24](#)).
- Unpin the energy chain from the storage bracket.
- Then, remove and store the storage bracket (1) as shown in View A.

On past production cranes, remove the user supplied cargo straps securing the energy chain to the VPC-MAX beam.

See [Figure 4-26](#) for the following procedure.

1. Remove the hitch pins (3a, View C) and tilt the energy chain frame (2) outward to the installation position.
2. Lift the energy chain (1) and roll it rearward to the end of the VPC-MAX beam (2).
3. Pivot the energy chain frame (3, View B) inward and install the hitch pins (3a, View C).
4. Remove the hitch pins (4, View B, [Figure 4-26](#)) from the energy chain (1).
5. Lower the energy chain (1, View B) onto the energy chain frame (3), align the connecting holes, and install the hitch pins (4).

Connect VPC-MAX Trolley Electric Cables

See [Figure 4-26](#) for the following procedure.

1. Disconnect the shorting plug (5, View B) from the receptacle (6).
2. Thoroughly clean the dust cap and connect it to the shorting plug (5).
3. If equipped, disconnect the dust cap from the end of the electric cable (7, View B).
4. Thoroughly clean the cable end and the receptacle.
5. Connect the electric cable (7) to the receptacle (6, View B).
6. Thoroughly clean the cable ends and connect the electric cable (8, View D) from the counterweight tray (9) to the electric cable in the right rear corner of the VPC-MAX trolley (10).

Connect VPC-MAX Trolley Hydraulic Hoses

See [Figure 4-26](#), View B for the following procedure.

1. Disconnect the dust caps from the hydraulic nipples on the bulkhead (11).

Store the dust caps on the bracket (1, View A, [Figure 4-16 on page 4-24](#)).

2. If equipped, disconnect the dust caps from the couplers on the ends of the hydraulic hoses (12). Store the couplers in the parts box.
 1. Thoroughly clean and lubricate the hydraulic nipples and couplers.
 2. Connect the hydraulic hose couplers to the hydraulic nipples on the bulkhead (11, View B).
 - Match the identification numbers on the hydraulic hoses with the numbers stamped into the bulkhead.
 - Connect the mating dust caps together as the hydraulic hoses are connected.

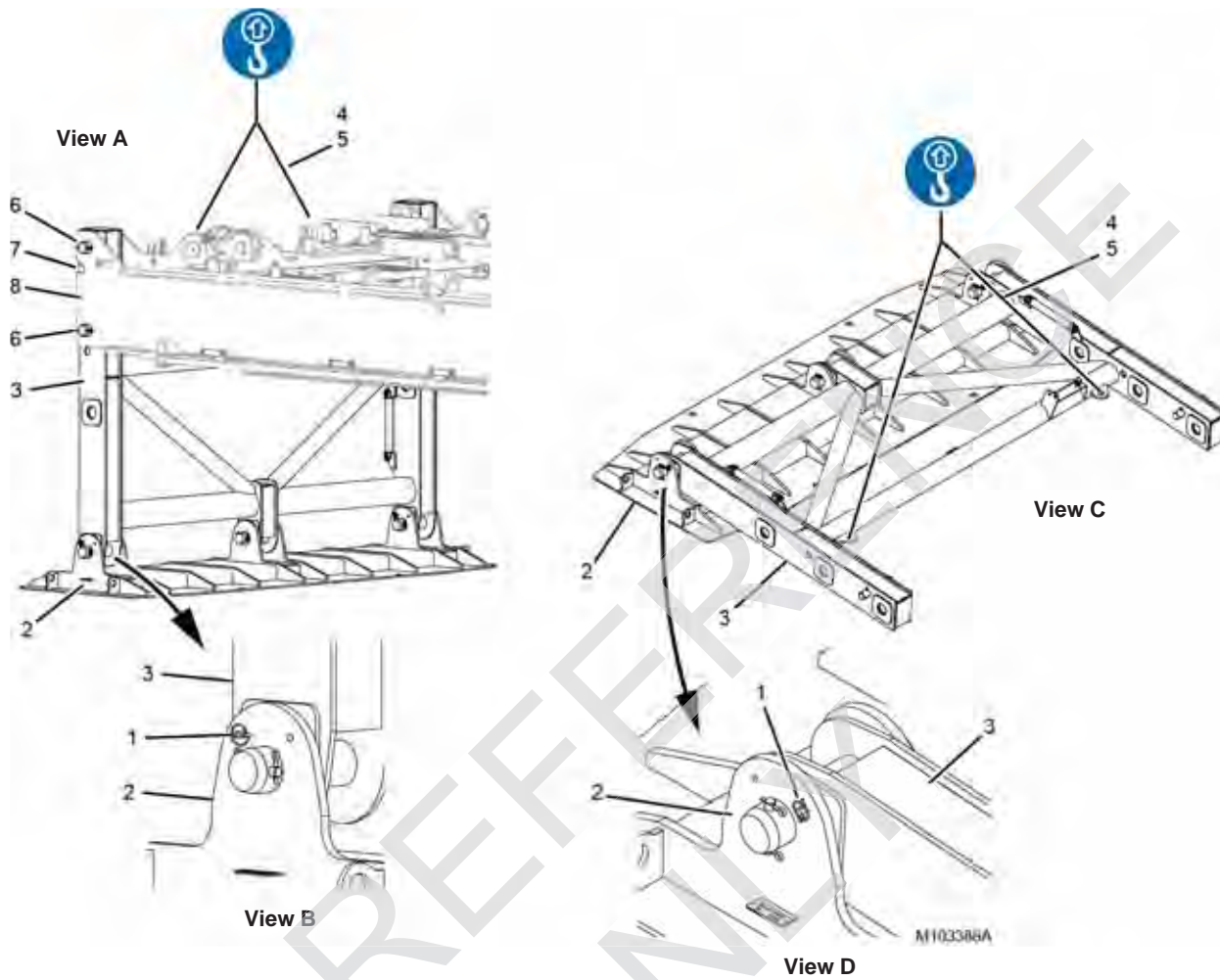

Item	Description
1	Pin with Quick-Release Pins (2)
2	Pad
3	Auxiliary Frame
4	Shackle (2): 20,5 t (23 USt)
5	Lifting Sling (2): 2,8m (9 ft) Long
6	Pin with Retaining Pins and Cotter Pins (4)
7	Alignment Pin (2)
8	VPC-MAX Beam

Figure 4-27

Check VPC-MAX Trolley Travel Limits and Calibration

- Verify that the VPC-MAX trolley limit switches operate properly. See Section 6 of this manual for the procedure.
- Verify that the VPC-MAX trolley position is properly calibrated. See the VPC-MAX Calibration Screen in the Main Display Manual for the procedure.



WARNING

Structural Damage Hazard!

A sudden release of load may cause structural damage due to shock loading and unintended motion of the crane.

The auxiliary frame assembly is provided to limit unintended motion of the VPC-MAX beam and counterweights during a sudden release of load.

The auxiliary frame assembly in no way substitutes for, or lessens, the requirement that the crane must be operated properly and safely, and that it must be inspected, serviced, and maintained regularly to minimize the potential for sudden release of the load.

Install Auxiliary Frame Assembly

See [Figure 4-27](#) for the following procedure.

1. Remove the tie-downs and blocking securing the auxiliary frame (3, View C) to the trailer.
2. Remove the pins (1, View D) to disconnect the pad (2) from the auxiliary frame (3).
3. Attach shackles (4, View C) and lifting slings (5) to the lugs on the auxiliary frame (3) and to the hook of the assist crane.
4. Lift the auxiliary frame assembly to vertical and remove the trailer.
5. Install the pins (1, View B) to connect the pad (2) to the auxiliary frame (3).
6. Remove the pins (6, View A) from the VPC-MAX beam (8).
7. Lift the auxiliary frame assembly into position at the end of the beam so the alignment pins (7, View A) engage the notches in the VPC-MAX beam (8).
8. Install the pins (6, View A) to connect the auxiliary frame (3) to the VPC-MAX beam (8).
9. Disconnect the shackles (4) and lifting slings from the auxiliary frame (3).

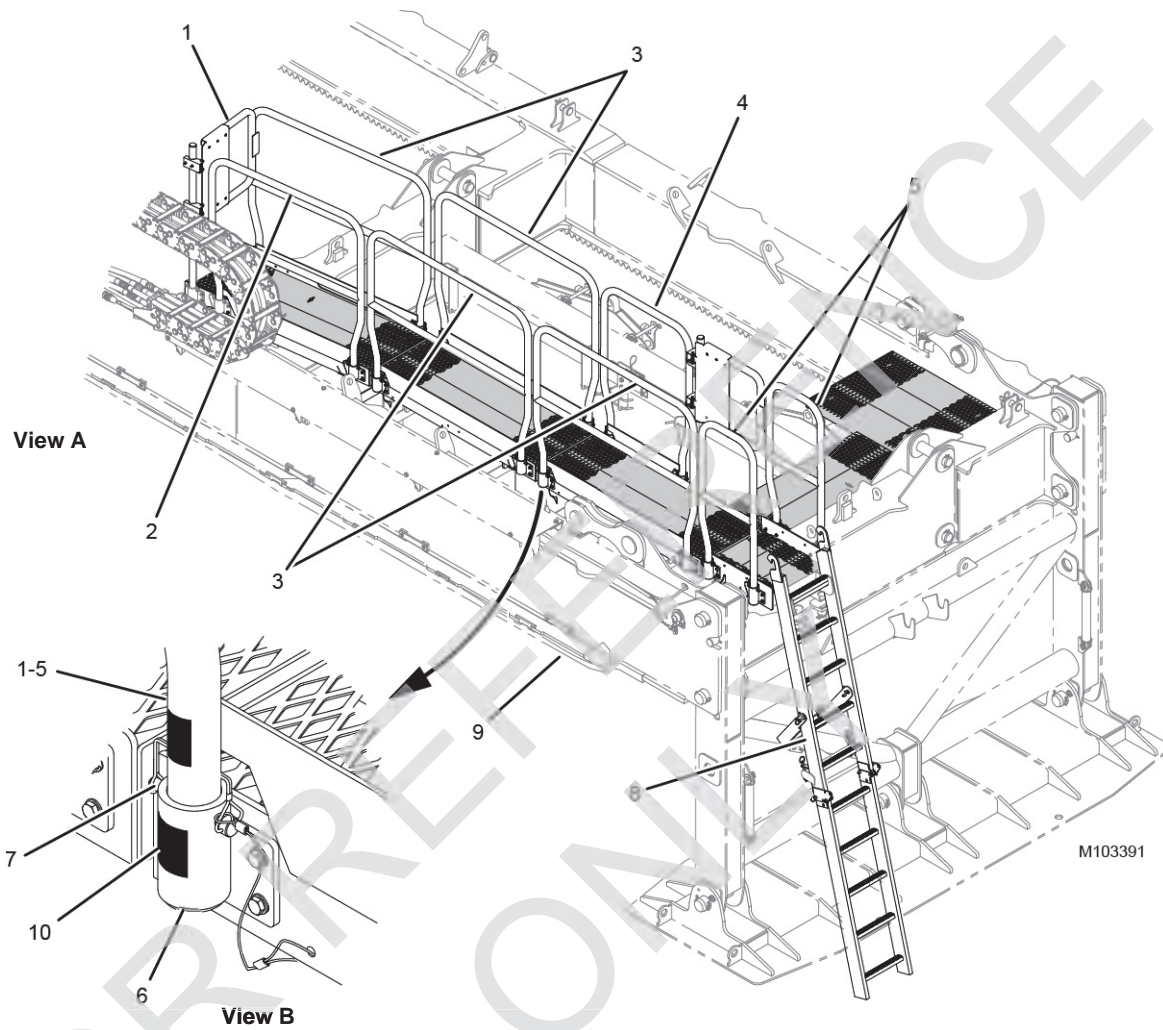

Item	Description	Item	Description
1	Handrail with Safety Barricade	6	Platform Assembly
2	Handrail	7	Safety Pin (1 or 2 each handrail)
3	Handrail (4)	8	Ladder (from crane)
4	Handrail with Safety Barricade	9	VPC-MAX Beam
5	Handrail (2)	10	Identification Number

Figure 4-28

Install Handrails

See [Figure 4-28](#) for the following procedure.

Use a hand-held tagline to lift each handrail into position. Match the identification number (10, View B) on the handrail with the number of the platform to ensure installation at the proper location.

1. Lift the desired handrail (1-5) into position with a tagline.

The heaviest handrail weighs 10 kg (22 lb).

2. Align the legs of the handrail with the pockets in the platform assembly (6, View B).
3. Align the connecting holes and install the safety pins (6).
4. Repeat the steps until all handrails (1-5) are installed.
5. Install ladder (8, View A) to access the top of the VPC-MAX beam (9). See [Install VPC-MAX Beam Ladder on page 4-47](#).

FOR REFERENCE ONLY

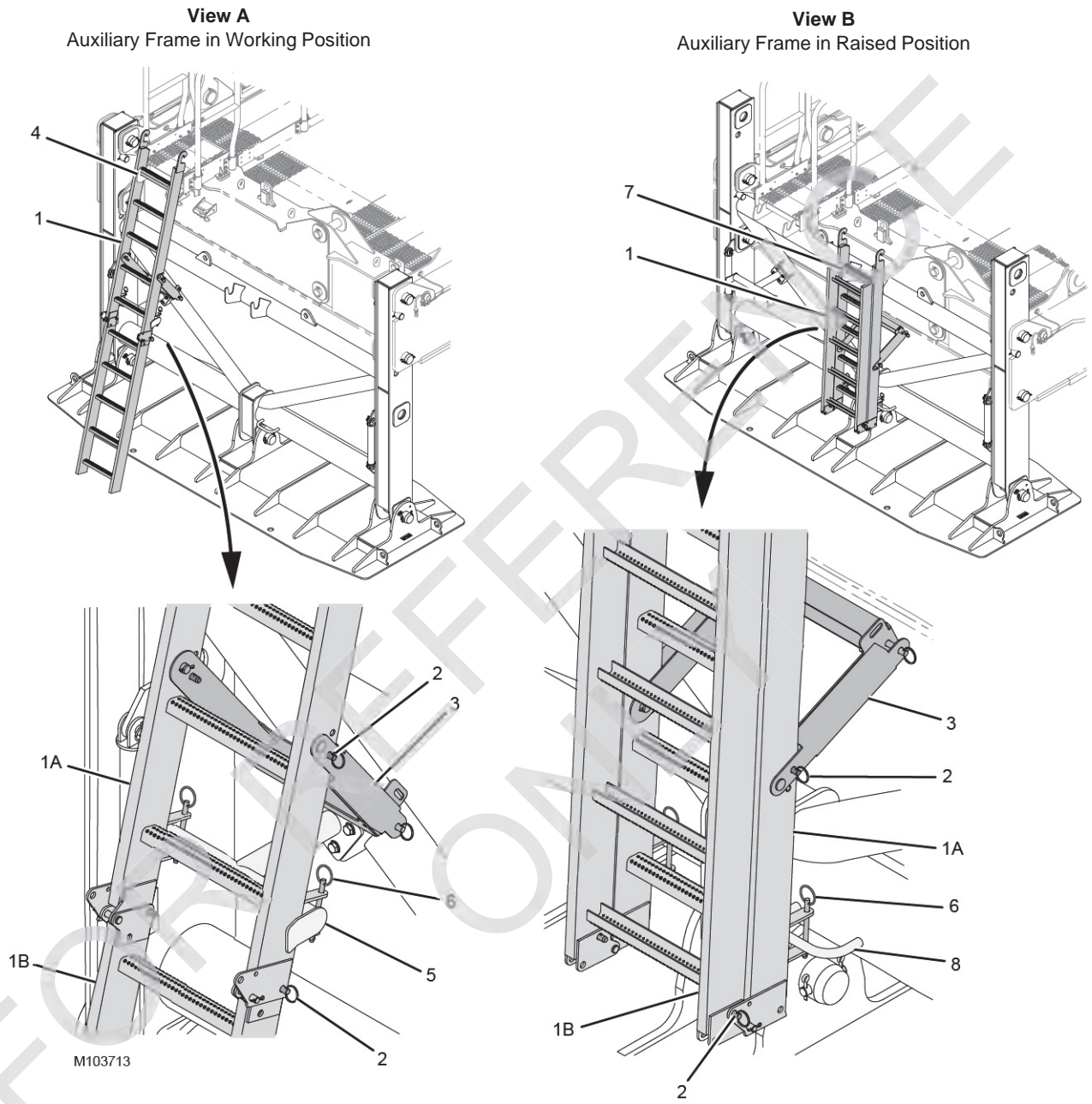

Item	Description	Item	Description
1	Ladder	4	Bracket (hook shaped) (2)
1A	Top Ladder	5	Bracket
1B	Bottom	6	Quick-Release Pin (2)
2	Quick-Release Pin (4)	7	Bracket (hook shaped) (2)
3	Support Bracket	8	Bracket

Figure 4-29

Install VPC-MAX Beam Ladder

The ladder from the rear of the crane can be moved to the rear of the VPC-MAX beam as described in the following procedures.

See [Figure 4-28](#) for the following procedures.

1. If the auxiliary frame is in the working position (View A), proceed as follows:
 - a. Secure the ladder (1, View A) in the stand-alone configuration:
 - The top ladder (1A) and the bottom ladder (1B) unfolded and pinned together with the quick-release pins (2).
 - The ladder support bracket (3) lowered and pinned to the bottom holes in the top ladder (1A) with the quick-release pins (2).
 - b. Hook the top rung of the ladder (1) onto the brackets (4) on the left side of the beam.
 - c. Secure the ladder (1) to the bracket (5) with the quick-release pins (6).
2. If the auxiliary frame is in the raised position (View B), proceed as follows:
 - a. Secure the ladder (1) in the stowed configuration:
 - The bottom ladder (1B) and the top ladder (1A) folded and pinned together with the quick-release pins (2).
 - The ladder support bracket (3) raised and pinned to the top holes in the top ladder (1A) with the quick-release pins (2).
 - b. Hook the top rung of the ladder (1) onto the brackets (7) on the center of the beam.
 - c. Secure the ladder (1) to the bracket (8) with the quick-release pins (6).

Item	Description
1	VPC-MAX Beam
2	VPC Trolley
3	Stop Block (2)
4	Rotating Bed
5	50 mm (2 in)
6	VPC-MAX Trolley
7	Counterweight Tray
8	547 mm (21-1/2 in)

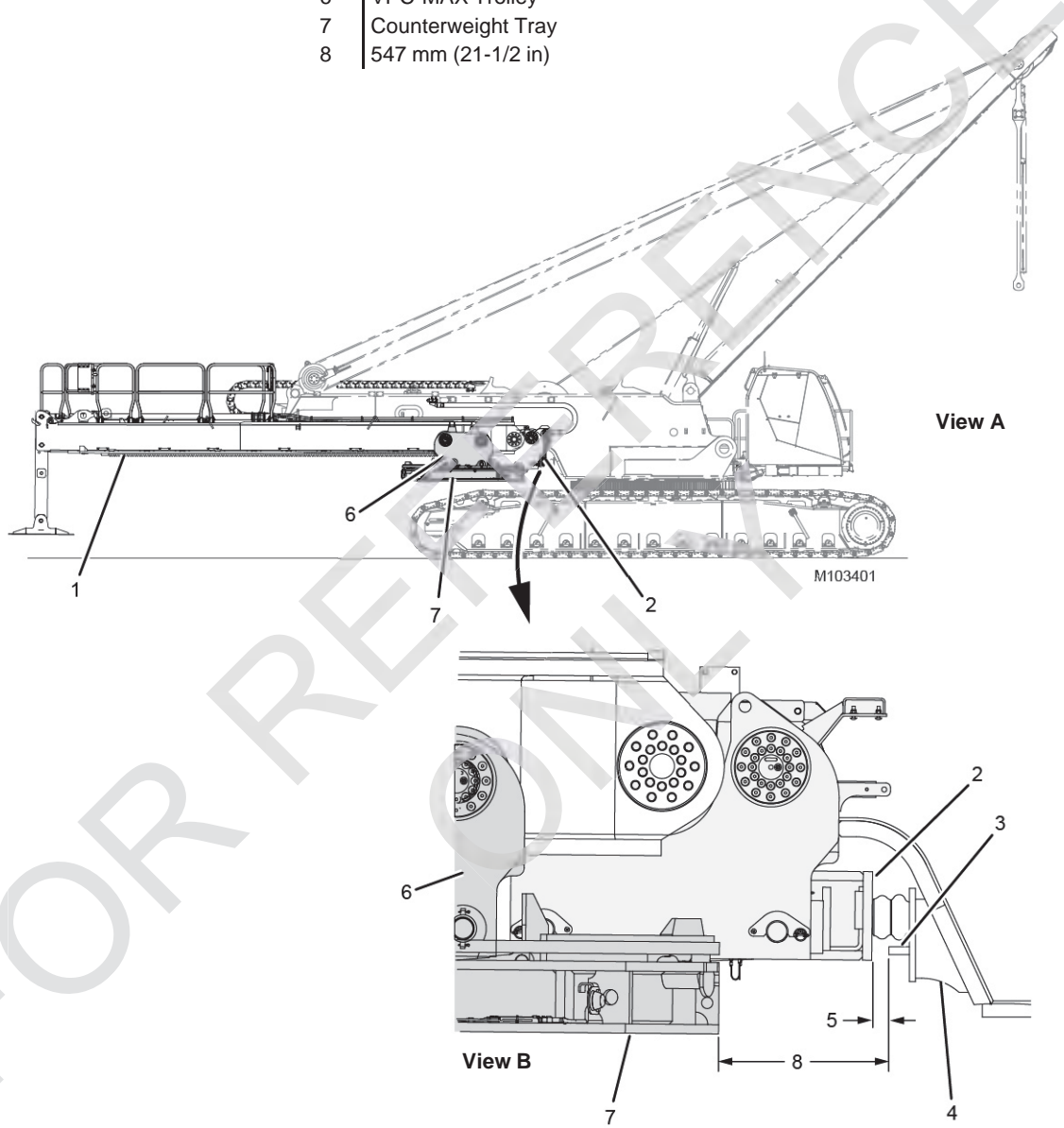

Figure 4-30

Position Counterweight Tray In Minimum Position

See [Figure 4-30](#) for the following procedure.

1. The VPC trolley (2, View B) should already be positioned at the minimum distance (5) between the VPC trolley (2) and the stop block (3) on both sides of the rotating bed (4).
2. Watch the scrapers (see [Figure 4-21 on page 4-32](#)) as the trolley is driven forward in [step 3](#). If necessary, adjust the scrapers so they are touching the roller paths.
3. Using the switch on the remote control, travel the VPC-MAX trolley (6, View B) forward until the counterweight tray is at the minimum distance (8) between the tray and the stop block (3) on both sides of the rotating bed (4).

Calibrate Position of VPC-MAX Trolley

See the VPC-MAX Calibration procedures in the MLC300 Main Display Manual.

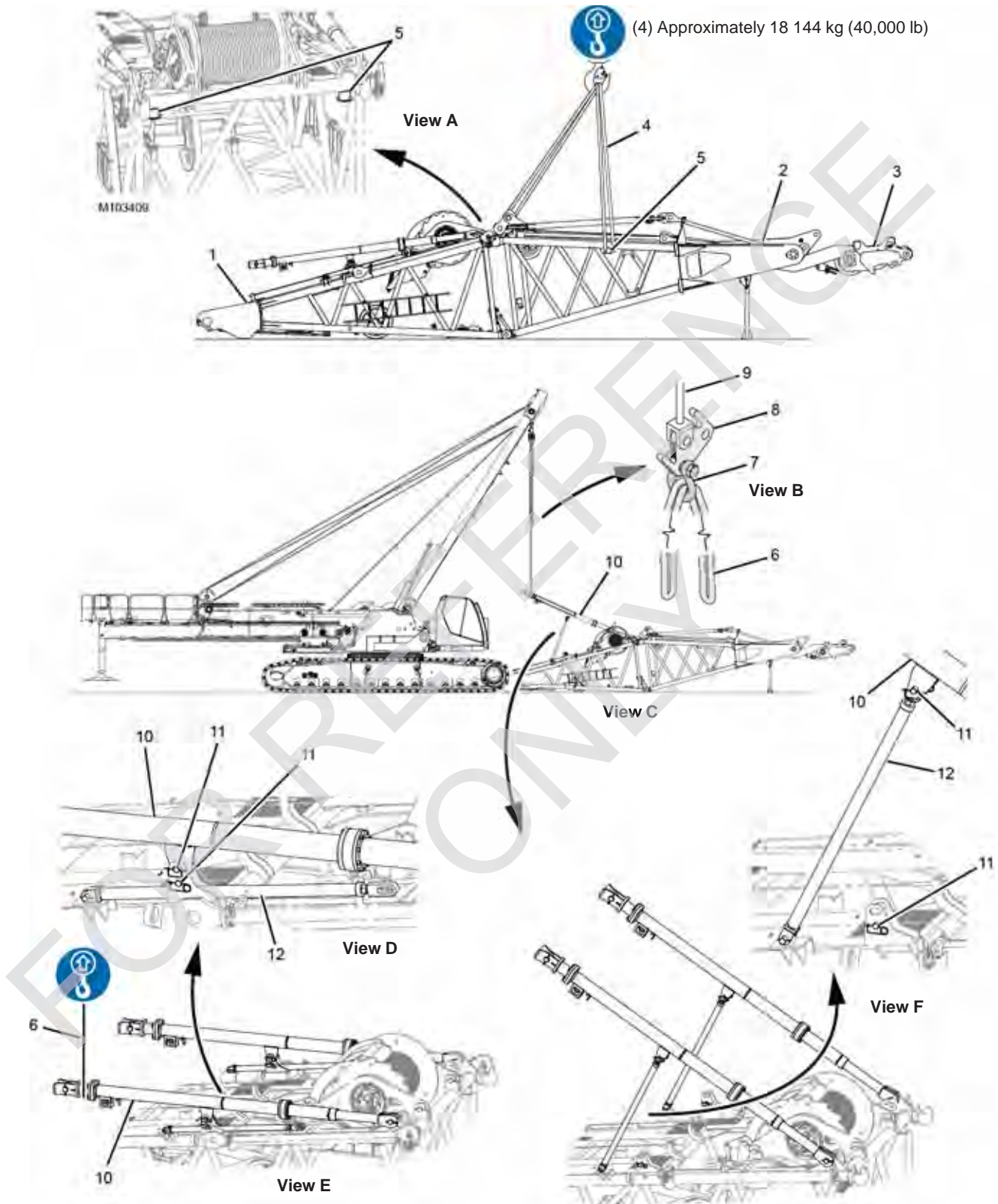

Figure 4-31

Legend for [Figure 4-31](#)

Item	Description
1	Fixed Mast Butt
2	Fixed Mast Top
3	Boom Hoist Equalizer
4	Lifting Sling (4): 2,8 m (9 ft) Long
5	Lifting Lug (4)
6	Lifting Sling (4): 4 m (13 ft) Long
7	Shackle: 25 t (28 USt)
8	Lifting Link
9	Self-Erect Cylinder
10	Mast Stop (2)
11	Pin with Safety Pin (4)
12	Strut (2)

5. Install the pin (11, View F) to the connect the strut (12) to the boom stop (10).
6. Install the other pin (11, View F) in the lugs on the mast butt.
7. Disconnect the lifting sling from the mast stop.
8. Repeat the steps for the other mast stop.
9. Disconnect the shackle (7, View B) and lifting sling (6) from the lifting link (8).

INSTALLING VPC-MAX #503 FIXED MAST

Remove Fixed Mast Butt and Top Assembly from Trailer

See [Figure 4-31](#) for the following procedure.

The fixed mast butt (1), Fixed mast top (2), and boom hoist equalizer (3) are shipped assembled as shown in View A.

1. Attach lifting slings (4, View A) to the hook of the assist crane and to the lifting lugs (5) on the fixed mast butt (1) and the fixed mast top (2).
2. Remove the tie-downs and blocking securing the fixed mast butt and top assembly to the trailer.
3. Lift the fixed mast butt and top assembly clear of the trailer and remove the trailer.
4. Place the fixed mast butt and top assembly on the ground in front of the MLC300 (View C). Do not disconnect the assist crane.

Verify Mast Stop Accumulator Pressure

Verify that the gauge on each mast stop reads the proper pressure as listed in the table in [Figure 4-32](#). Take corrective action if the either gauge does not read the proper pressure. Contact the Manitowoc Crane Care Lattice Team.

Raise Mast Stops

See [Figure 4-31](#) for the following procedure.

1. Connect the shackle (7, View B) and the lifting sling (6) to the lifting link (8) on the self-erect cylinder (9).
2. Connect the ends of the lifting sling (6, View E) to the mast stop (10).
3. Remove the top pin (11, View D) and raise the mast stop (10) to the operating position (View F).
4. Remove the bottom pin (11, View D) and raise the strut (12), by hand, to the operating position.



Item	Description
1	Mast Stop Gauge (2)

Pressure Reading Cylinder Part #84030450	
19,1 bar at -1°C	277 psi at 30°F
19,5 bar at 4°C	283 psi at 40°F
19,9 bar at 10°C	289 psi at 50°F
20,3 bar at 16°C	294 psi at 60°F
20,7 bar at 21°C	300 psi at 70°F
21,1 bar at 27°C	306 psi at 80°F
21,5 bar at 32°C	311 psi at 90°F
21,9 bar at 38°C	317 psi at 100°F

Pressure Reading Cylinder Part #84034173	
12,7 bar at -1°C	185 psi at 30°F
13,0 bar at 4°C	189 psi at 40°F
13,3 bar at 10°C	192 psi at 50°F
13,5 bar at 16°C	196 psi at 60°F
13,8 bar at 21°C	200 psi at 70°F
14,0 bar at 27°C	204 psi at 80°F
14,3 bar at 32°C	208 psi at 90°F
14,6 bar at 38°C	211 psi at 100°F

NOTE The cylinder part number is provided on the identification plate on each cylinder.

Figure 4-32

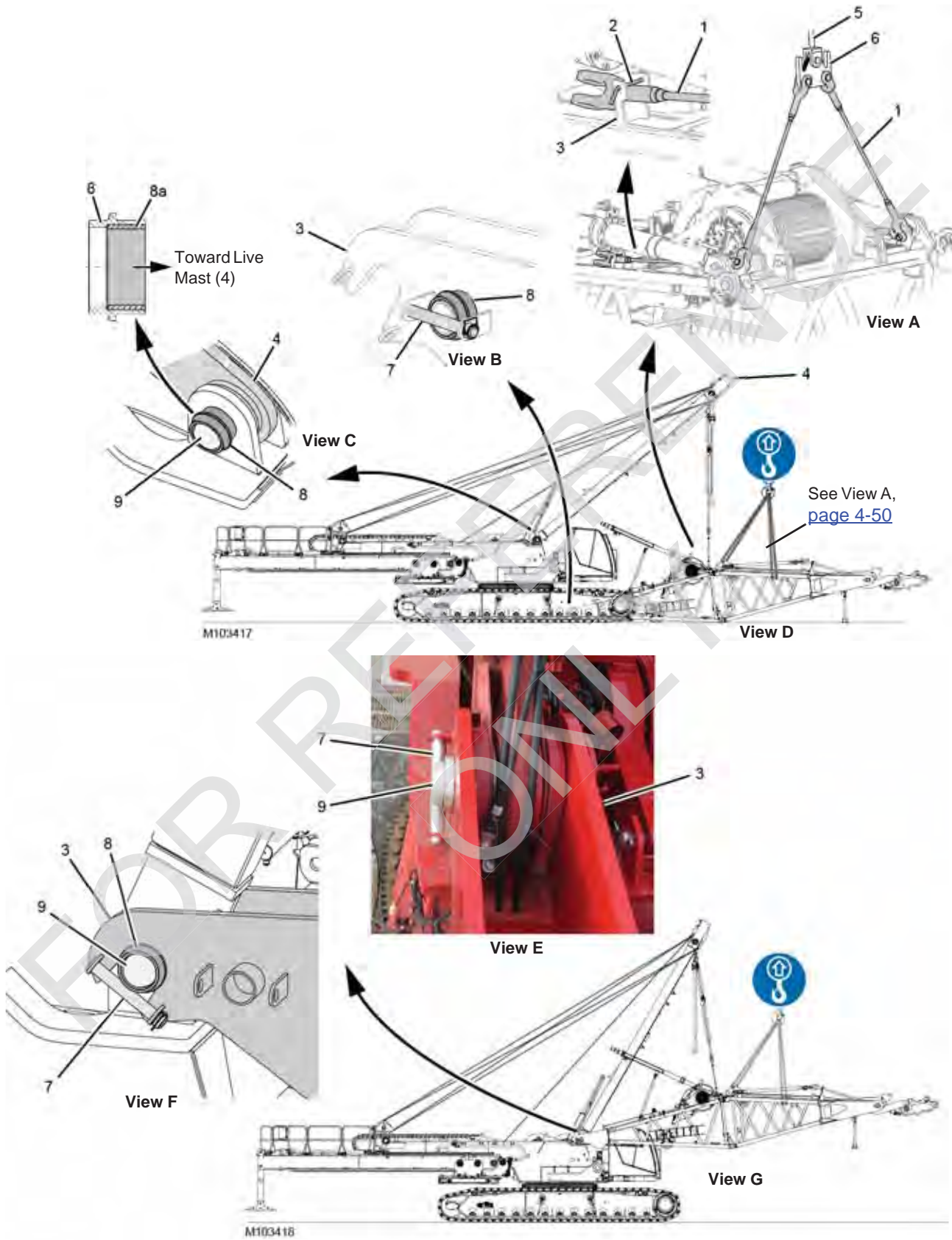

Figure 4-33

Legend for [Figure 4-33](#)

Item	Description
1	Handling Pendant (2)
2	Hitch Pin with Hair-Pin Cotter (2)
3	Fixed Mast Butt
4	Live Mast
5	Self-Erect Cylinder
6	Lifting Link
7	Pin with Collar and Safety Pin (2)
8	Sleeve Assembly (2)
8a	Bushing
9	Mast Hinge Pin (2)

Connect Fixed Mast Butt and Top Assembly to Crane

See [Figure 4-33](#) for the following procedure.

1. Position the crane with relation to the fixed mast butt and top assembly as shown in View A.

Allow for 152-305 mm (6-12 in) clearance between the end of the carbody platform and the end of the fixed mast butt.

2. Attach a hand-held tagline to the end of the fixed mast top so an assembler can assist in guiding the fixed mast butt and top assembly as it is lifted.
3. Also attach a hand-held tagline to each fixed mast stop so assemblers can assist in guiding the fixed mast stops clear of the live mast.

Leave the taglines attached the fixed mast stops until after the fixed mast is raise later in the assembly procedure.

CAUTION Mast Damage!

The fixed mast stops can contact the live mast when the live mast is raised and lowered.

To avoid damage, use the hand-held taglines to pull the fixed mast stops away from the live mast as it is raised and lowered.

4. Unpin the handling pendants (1, View A) from storage on the fixed mast butt (3).

5. Store the pins (2, View A) in the lugs on the fixed mast butt (3).

6. Lower the live mast (4, View D) and extend the self-erect cylinder (5, View A) as needed.

The live mast should be at approximately 140°.

7. Pin the handling pendants (1, View A) to the lifting link (6) on the self-erect cylinder (5).

8. Remove the pins (7, View B) and the sleeve assemblies (8) from storage on the fixed mast butt (3).

9. Install the sleeve assemblies (8, View C) on the mast hinge pins (9) so that **bushings (8a) are toward live mast (4)** as shown.

10. **SLOWLY** lift the fixed mast butt and top assembly with the assist crane while following with the live mast.

11. **Guide** the fixed mast butt clear of the platform on the front of the carbody.

12. **To avoid damage**, use the hand-held taglines to guide the fixed mast stops clear of the live mast.

13. Continue to lift the fixed mast butt and top assembly with the assist crane while raising the live mast.

14. Engage the hooked ends of the fixed mast butt (3, View F) with the sleeve assemblies (8).

Take care not to damage the hydraulic hoses and electric cable near the right side mast hinge pin (9, View E). The hoses and cables must be routed between the legs of the fixed mast butt (3) as shown.

15. Install the pins (7, View F).

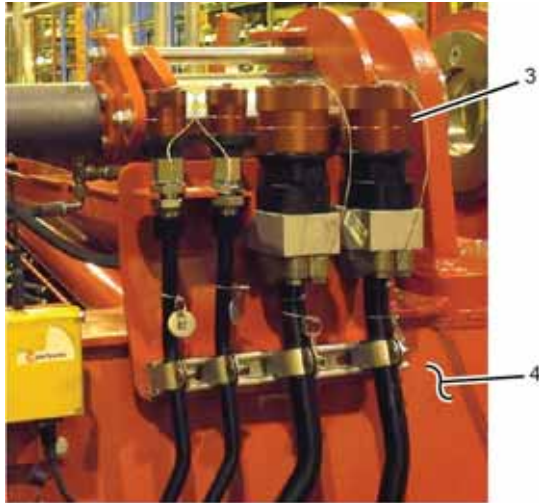

M103727

View A
PAST

Item	Description
1	Hydraulic Hoses (4 or 6)
2	Storage Couplers (4 or 6)
3	Hydraulic Couplers (4 or 6)
4	Left Side of Rotating Bed
5	Electric Cable
6	Electric Receptacle
7	Junction Box (right side of rotating bed)
8	Drum 5 Camera Cable
9	VPC-MAX Camera Cable
10	Camera Switcher

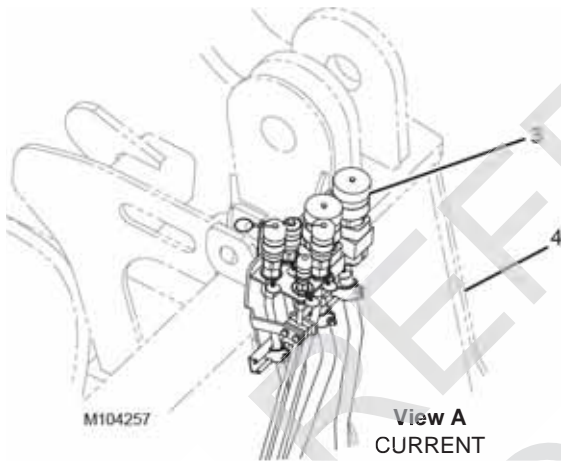

M104257

View A
CURRENT



M103728

View B



M104266

View D

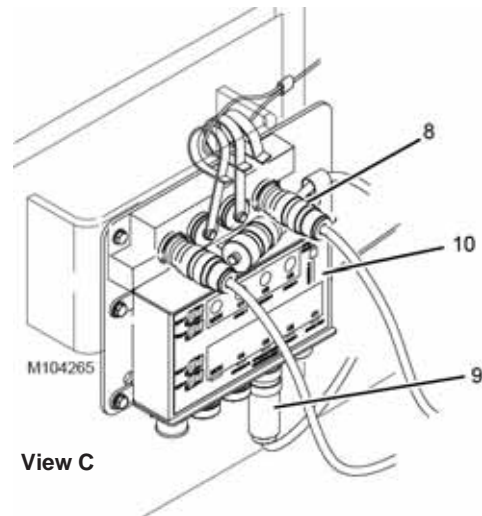

M104265

View C

Figure 4-34

Connect Fixed Mast Hydraulic Hoses

See [Figure 4-34](#) for the following procedure.

1. Disconnect the hydraulic hoses (1, View D) from the storage couplers (2) on the fixed mast butt.
2. Disconnect the dust caps from the hydraulic couplers (3) on the left side of the rotating bed (4).
3. Thoroughly clean and lubricate the hydraulic nipples and couplers.
4. Connect the hydraulic hoses (1) to the hydraulic couplers (3, View A).

Match the identification numbers on the hydraulic hoses with the numbers on the couplers.

Connect Fixed Mast Electric Cable

See [Figure 4-34](#) for the following procedure.

1. Disconnect the dust cap from the electric cable (5, View D) on the fixed mast butt and from the receptacle (6,

View B) on the junction box (7) on the right side of the rotating bed.

2. Thoroughly clean the end of the electric cable and the receptacle.
3. Connect the electric cable (5) to the receptacle (6).

Connect Fixed Mast Camera Cables

See [Figure 4-34](#) for the following procedure.

1. Disconnect the dust caps from the optional camera cables (8 and 9, View D) on the fixed mast butt and from the camera switcher (10, View C) on the left side of the rotating bed.
2. Thoroughly clean the ends of the camera cables and the receptacles on the camera switcher.
3. Connect the camera cables (8 and 9, View C) to the receptacles on the camera switcher (10).

Refer to the decal on the camera switcher for proper connection of the cables.

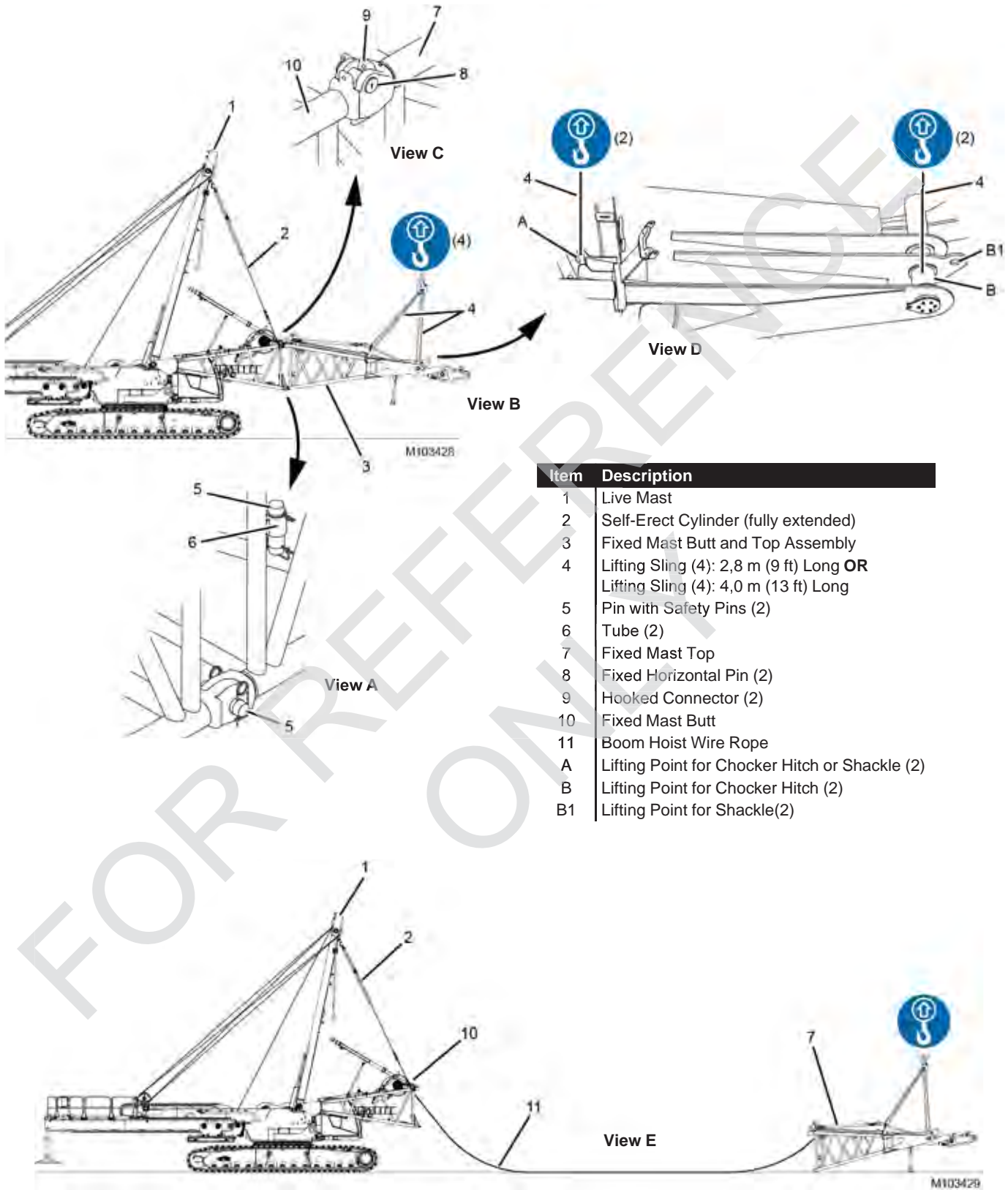

Figure 4-35

Disconnect Fixed Mast Top from Fixed Mast Butt

NOTE: The following steps assume the crane is in the Live Mast Configuration which, with Drum 6 parked, allows operation of Drums 4 and 5 at the same time.

See [Figure 4-35](#) for the following procedure.

1. Raise the live mast (1, View B) and extend the self-erect cylinder until the cylinder is fully extended.

11. Pay out wire rope from Drum 5 in the fixed mast butt while performing [step 12](#).
12. Lift the fixed mast top (7, View E) away from fixed mast butt (10) and place the fixed mast top on the foundation 20-25 m (66-82 ft) in front of fixed mast butt as shown.
13. Lay the boom hoist wire rope (11, View E) from Drum 5 on the foundation alongside the fixed mast butt and top so the wire rope does not interfere with installation of the fixed mast inserts.



WARNING

Falling Load Hazard!

Do not allow assembly personnel to walk on the fixed mast butt and top assembly until after [step 1](#) through [step 3](#) are performed.

The assembly personnel can fall or be thrown off the fixed mast butt and top assembly if this precaution is not taken.

2. Lower the live mast until the centerline of the fixed mast butt and top assembly is horizontal (View B).
3. Place the Drum 4 park switch on the front control console in the PARK position. This step will apply the Drum 4 brake and engage the drum pawl.
4. The assembly personnel can now walk out on the fixed mast butt and top assembly (3, View B) to perform [step 5](#).
5. Disconnect the lifting slings from the lifting lugs on the fixed mast butt and top and from the assist crane.
6. Using chocker hitches, attach the lifting slings (4, View D) to the lifting points (A and B) and to the hook of the assist crane.

NOTE As an alternative to the chocker hitches, the lifting slings (4, View D) can be attached to owner furnished shackles. Attach the shackles to the lifting points (A and B1, View D).

7. Assembly personnel **must not be on the fixed mast butt and top assembly** while performing [step 8](#).
8. Hoist with the assist crane so the lifting slings are just taut.
9. Remove both bottom pins (5, View A) and store them in the tubes (6) on the fixed mast top (7).
10. Using the assist crane, lift the fixed mast top (7) so the fixed horizontal pins (8, View C) in the fixed mast top disengage the hooked connectors (9) on the fixed mast butt (10).

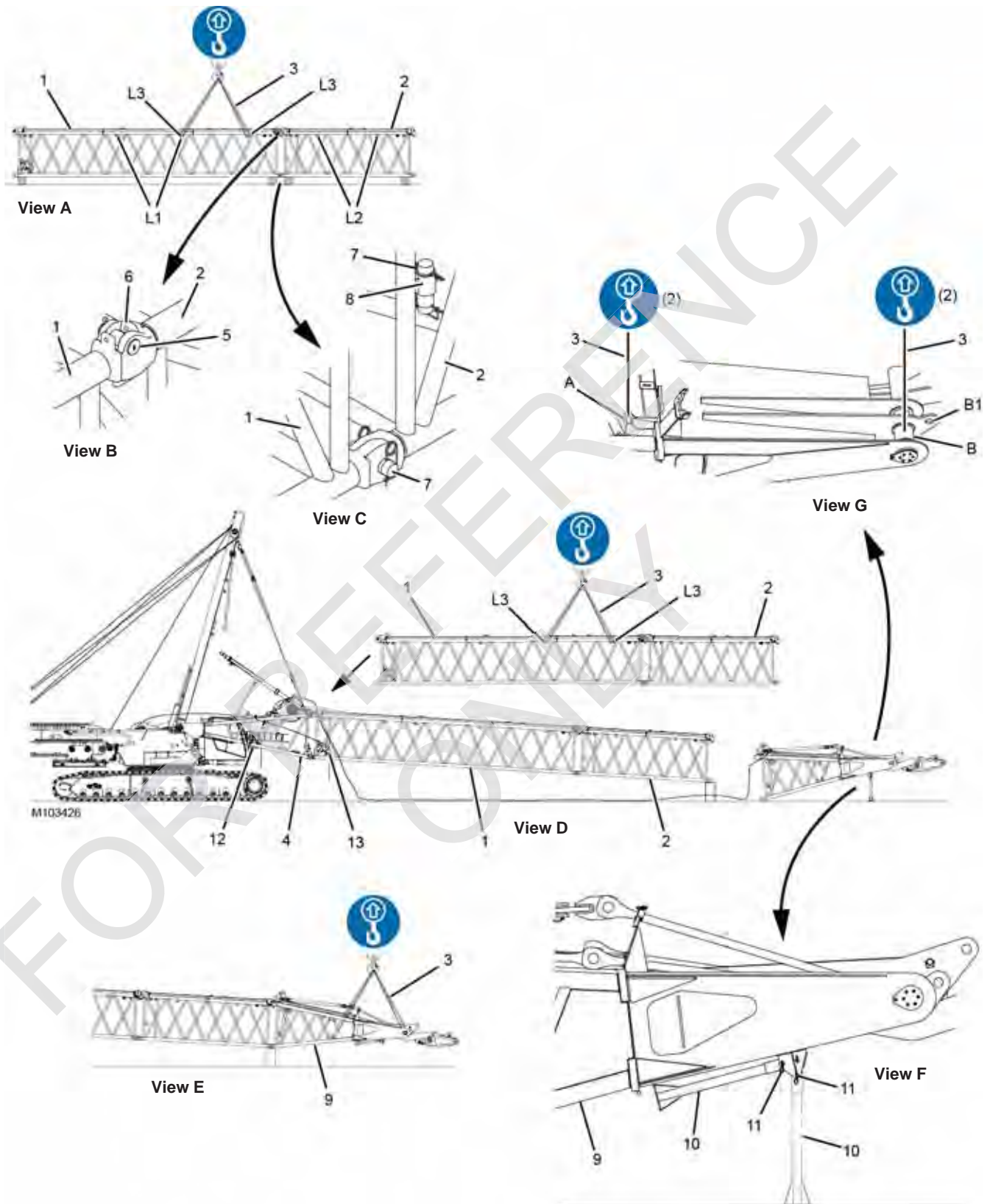

Figure 4-36

Legend for [Figure 4-36](#)

Item	Description
1	Insert: 12 m (39.4 ft)
2	Insert: 6 m (19.7 ft)
3	Lifting Sling (4): 2,8 m (9 ft) Long OR Lifting Sling (4): 2,8 m (9 ft) Long
4	Fixed Mast Butt
5	Fixed Horizontal Pin (2)
6	Hooked Connector (2)
7	Pin with Safety Pins (2)
8	Tube (2)
9	Fixed Mast Top
10	Support (2)
11	Pin with Hair-Pin Cotter (2)
12	Guide Sheave (Drum 2)
13	Guide Sheave (Drum 3)
L1	Lifting Lug (4, for lifting 12 m insert)
L2	Lifting Lug (4, for lifting 6 m insert)
L3	Lifting Lug (4, for lifting 12m and 6 m inserts)

Assemble and Install Fixed Mast Inserts

See [Figure 4-36](#) for the following procedure.

Refer to View A for lifting lug identification.

- Connect the lifting slings (3, View A) from the assist crane to the lifting lugs (L1) on the insert (1).
- Place the insert (1) onto blocking in front of the fixed mast butt (4).
The blocking must be at least 203 mm (8 in) high.
- Disconnect the lifting slings (3) from the insert (1).
- Connect the lifting slings (3, View A) to the lifting lugs (L2) on the insert (2).
- Lift the insert (2) into position at the end of the fixed mast insert (1).
- Connect the inserts together:
 - Lift the insert (2, View B) into position so the fixed horizontal pins (5) on the insert (2) engage the hooked connectors (6) on the insert (1).
 - Lower the insert (2) to align the bottom connecting holes and install the pins (7, View C).
The pins (7) are stored in the tubes (8) on the insert (2).
 - Block under the top end of the insert (2).
 - Disconnect the lifting slings (4) from the insert (2).
- Connect the lifting slings (3, View A) to the lifting lugs (L3) on the insert (1).
- Connect the inserts to the fixed mast butt (4, View D) in the same manner the inserts were connected together. See Views B and C.
- The assembled inserts (1 and 2, View D) can be cantilevered from the fixed mast butt (2).
- Lower the inserts onto blocking at least 0,6 m (2 ft) high.

CAUTION Mast Damage!

Do not attempt to raise the fixed mast with the live mast self-erect cylinder once the fixed mast top is installed. Damage to the cylinder or the live mast may occur.

- Using choker hitches, attach the lifting slings (3, View G) to the lifting points (A and B) in the fixed mast top and to the hook of the assist crane.

NOTE As an alternative to the choker hitches, the lifting slings (4) can be attached to owner furnished shackles. Attach the shackles to the lifting points (A and B1, View G).

- Lift the fixed mast top into position at the end of the inserts.
- Store the fixed mast top supports (10, View F):
 - Remove pins (11).
 - Rotate the supports (10) to the stored position.
 - Install pins (11).
- Connect the fixed mast top (9, View E) to the insert (2) in the same manner the inserts were connected to the fixed mast butt. See Views B and C.
- Payout and route the load lines from Drums 2 and 3 over the top of the guide sheaves (12 and 13, View D).
 - Drum 2 wire rope over guide sheave (12)
 - Drum 3 wire rope over guide sheave (13)

Pay out at least 36 m (118 ft) of wire rope from both drums so the wire rope is accessible after the fixed mast is raised.

Item	Description
1	Live Mast
2	Self-Erect Cylinder
3	Handling Pendants (2)
4	Mast Assist Arms (2)
5	Lifting Link
6	Storage Lugs
7	Live Mast Straps (2)
8	Fixed Mast Insert

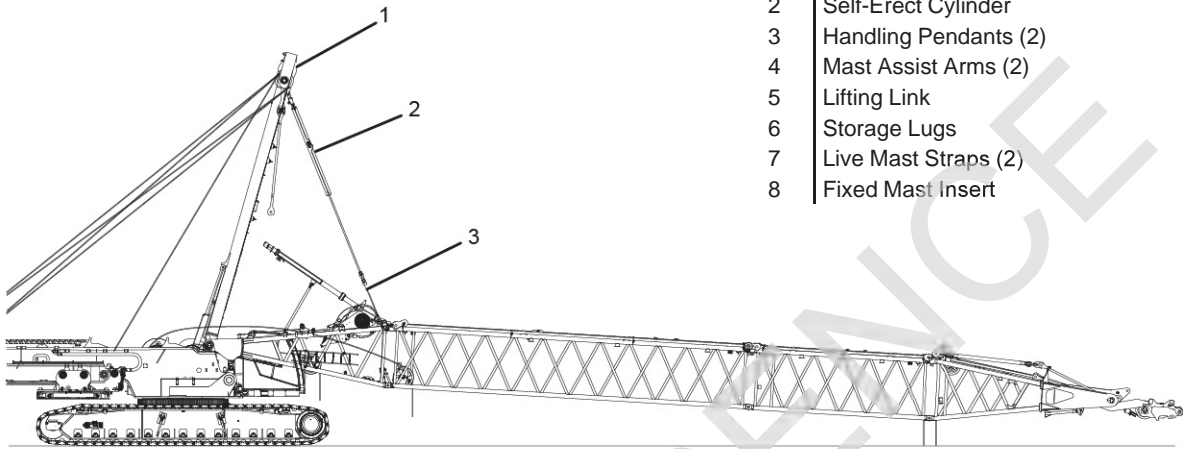

View A

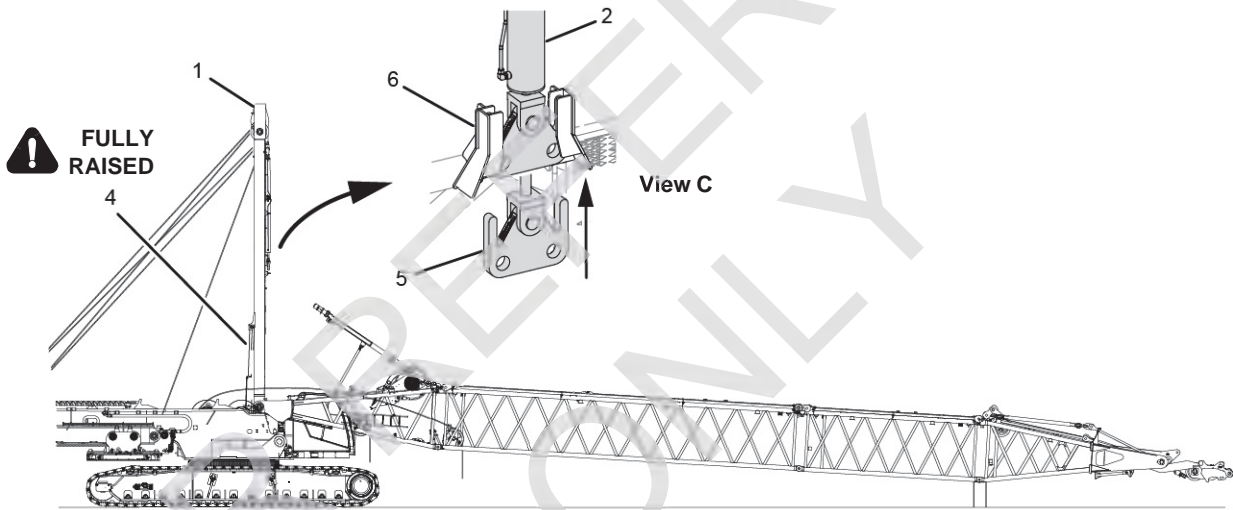

View B

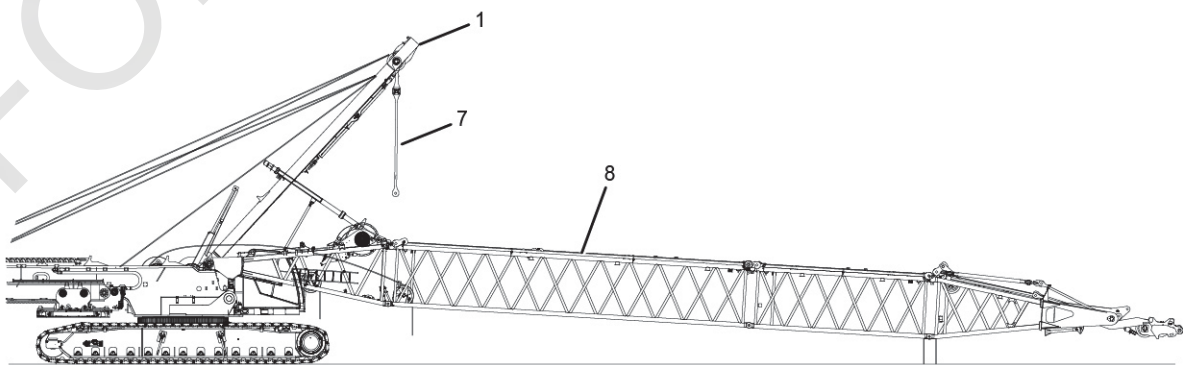

View D

M103427

Figure 4-37

Store Handling Pendants

See [Figure 4-37](#) for the following procedure.

1. **To avoid damage**, use hand-held taglines to guide the fixed mast stops clear of the live mast as the live mast is lowered.
2. Lower the live mast (1, View A) until the handling pendants (3) are slack.
3. Disconnect the handling pendants from the self-erect cylinder and store the pendants as shown in View A, [Figure 4-33 on page 4-52](#).

Store Self-Erect Cylinder

See [Figure 4-37](#) for the following procedure.

1. Confirm that the mast assist arms (4, View B) are fully raised before proceeding.

NOTE When the Live Mast Configuration is ON, the following will occur if you attempt to raise the live mast when the mast assist arms are down:



- The live mast will stop rising.
 - The hazard warning will come on and the MAST ASSIST ARMS DOWN icon will appear in the fault bar of the Main Display Working Screen.
 - Make sure the mast assist arms are up before raising the live mast to vertical.
2. Secure the self-erect cylinder (2, View C) in the stored position:
 - a. Make sure the lifting link (5, View C) and the storage lugs (6) are properly aligned.
If necessary, jog the self-erect cylinder switch on the remote control or the drum control handle in the cab to relieve the pressure in the cylinder. Then, using the lifting link, rotate the cylinder rod by hand to properly position the link and storage lugs.
 - b. Boom up until the live mast (1, View B) is vertical (90°).
 - c. Slowly retract the self-erect cylinder (3, View C) until the lifting link (5) fully engages the storage lugs (6).
 - d. Turn OFF the self-erect cylinder in the Main Display.
 3. **To avoid damage**, use hand-held taglines to guide the fixed mast stops clear of the live mast as the live mast is lowered.
 4. Lower the live mast (1, View C) until the live mast straps (7) are hanging vertical over the fixed mast insert (8).

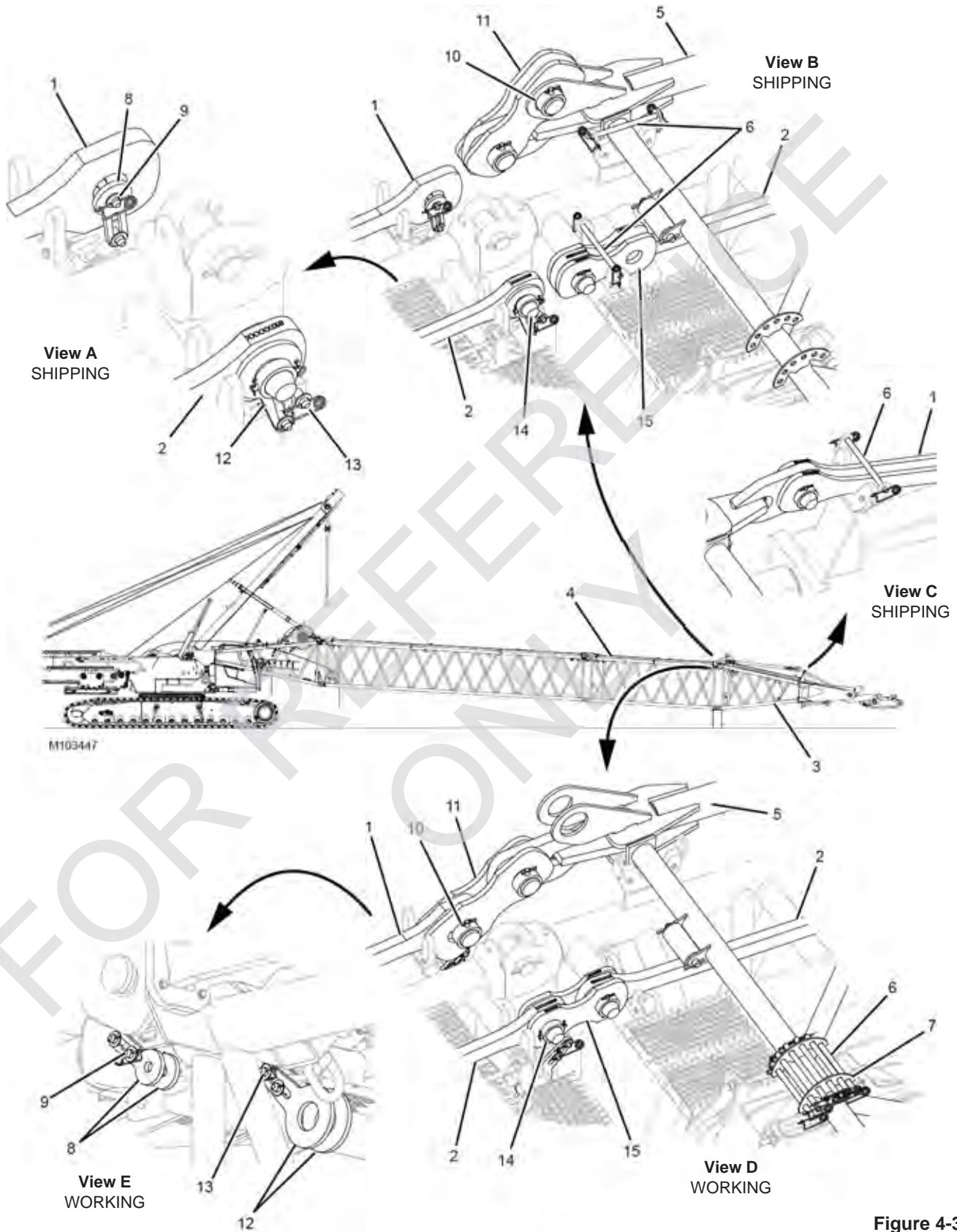

Figure 4-38

Legend for [Figure 4-38](#)

Item	Description
1	Counterweight Strap (2)
2	Mast Strap (4)
3	Mast Top
4	Mast Insert (6 m)
5	Spreader Beam
6	Retaining Pin with Safety Pins(6)
7	Bracket
8	Strap Bracket (4)
9	Pin with Safety Pins and Flat Washers (4)
10	Pin with Collar, Retaining Pin, and Cotter Pins (2)
11	Link (4)
12	Strap Bracket (4)
13	Pin with Safety Pins and Flat Washers (2)
14	Pin with Collar, Retaining Pin, and Cotter Pins (2)
15	Link (4)

Connect Straps at Mast Top

See [Figure 4-38](#) for the following procedure.

Connect the straps (1 and 2) between the mast top (3) and the 6 m insert (4), as follows:

1. Remove the retaining pins (6, Views B and C) and store them in the bracket (7, View D) on the spreader beam (5).
2. Unpin the strap brackets (8, View A) from the shipping position and pin them in the working position (View E).
3. Remove the pin (10, View B).
4. Rotate the links (11, View B) rearward from the shipping position to the working position (View D).
5. Install the pin (10, View D). The PIN HEAD MUST FACE OUT (collar facing center of mast section).
6. Unpin the strap brackets (12, View A) from the shipping position and pin them in the working position (View E).
7. Remove the pin (14, View B).
8. Rotate the links (15, View B) rearward from the shipping position to the working position (View C).
9. Install the pin (14, View C). The PIN HEAD MUST FACE OUT (collar facing center of mast section).
10. Repeat the above steps for the straps on both sides of mast top.

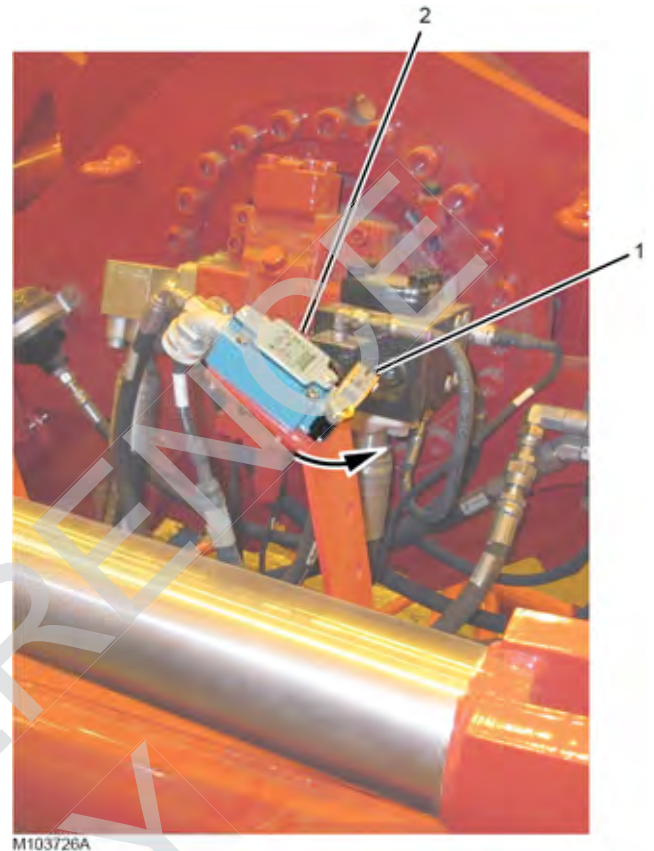

M103726A

Item	Description
1	Lever
2	Mast Stop Limit Switch

Figure 4-39

Test Mast Stop Limit Switch

See [Figure 4-39](#) for the following procedure.

1. If necessary, reposition the lever (1) so it is perpendicular (90°) to body of the mast stop limit switch (2).
2. Start the engine (if off).
3. Make sure the fixed mast configuration is selected in the RCL/RCI Display
4. Rotate the lever (1) counterclockwise.
5. The hazard warning should come on and the MAST STOP FAULT icon should appear in the fault bar of the main display.
6. Release the lever (1) and the hazard warning and MAST STOP FAULT icon should go off.
7. If the fault does not appear in the main display, troubleshoot the electric control system and correct the problem.



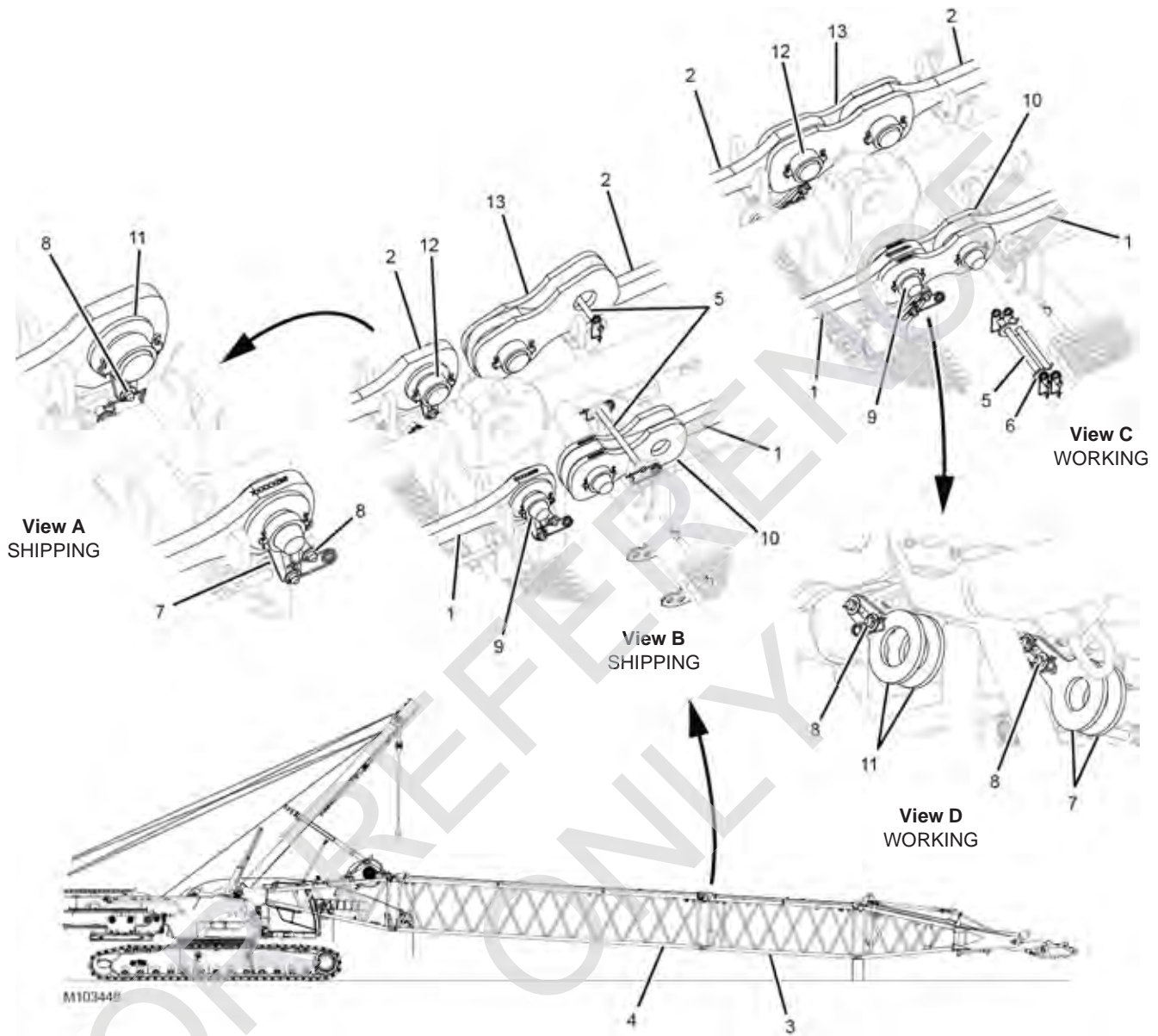

Figure 4-40

Legend for [Figure 4-40](#)

Item	Description
1	Mast Strap (4)
2	Counterweight Strap (4)
3	Mast Insert (6 m)
4	Mast Insert (12 m)
5	Retaining Pin with Safety Pins (6)
6	Bracket
7	Strap Bracket (4)
8	Pin with Safety Pins and Flat Washers (8)
9	Pin with Collar, Retaining Pin, and Cotter Pins (2)
10	Link (4)
11	Strap Bracket (4)
12	Pin with Collar, Retaining Pin, and Cotter Pins (2)
13	Link (4)

Connect Straps at Mast Inserts

See [Figure 4-40](#) for the following procedure.

Connect the straps (1 and 2) between the 6 m mast insert (3) and the 12 m insert (4), as follows:

1. Remove the retaining pins (5, View B) and store them in the bracket (6, View C) on the 6 m insert (3).
2. Remove the pin (9, View B).
3. Unpin the strap brackets (7, View A) from the shipping position and pin them in the working position (View D).
4. Rotate the links (10, View B) rearward from the shipping position to the working position (View C).
5. Install the pin (9, View C). The PIN HEAD MUST FACE OUT (collar facing center of mast section).
6. Remove the pin (12, View B).
7. Unpin the strap brackets (11, View A) from the shipping position and pin them in the working position (View D).
8. Rotate the links (13, View B) rearward from the shipping position to the working position (View C).
9. Install the pin (12, View C). The PIN HEAD MUST FACE OUT (collar facing center of mast section).
10. Repeat the above steps for the straps on both sides of the mast inserts.

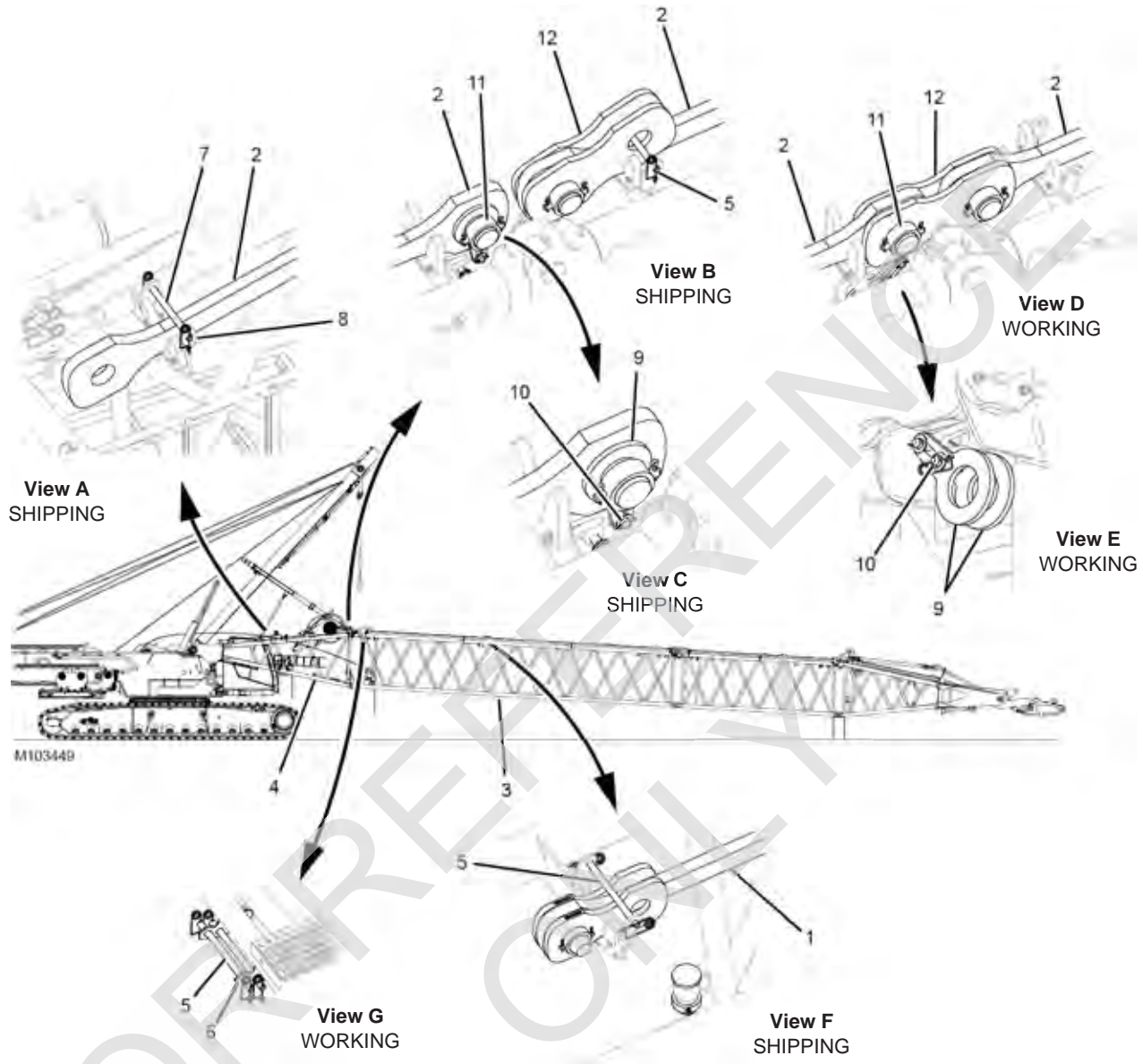

Figure 4-41

Legend for [Figure 4-41](#)

Item	Description
1	Mast Strap (2)
2	Counterweight Strap (2)
3	Mast Insert (12 m)
4	Mast Butt
5	Retaining Pin with Safety Pins(4)
6	Bracket
7	Retaining Pin with Safety Pins (2)
8	Bracket
9	Strap Bracket (4)
10	Pin with Safety Pins and Flat Washers (8)
11	Pin with Collar, Retaining Pin, and Cotter Pins (2)
12	Link (4)

Connect Straps at Mast Butt

See [Figure 4-41](#) for the following procedure.

Connect the straps (2) between the 12 m mast insert (3) and the mast butt (4), as follows:

1. Remove the retaining pins (5, Views B and E) and store them in the bracket (6, View G) on the end of the 12 m insert (3).
2. Remove the retaining pin (7, View A) and store it in the bracket (8).
3. Remove the pin (11, View B).
4. Unpin the strap brackets (9, View C) from the shipping position and pin them in the working position (View E).
5. Rotate the links (12, View B) rearward from the shipping position to the working position (View D).
6. Install the pin (11, View D). The PIN HEAD MUST FACE OUT (collar facing center of mast section).
7. Repeat the above steps for the straps on both sides of the mast inserts.
8. Attach a 15 m (50 ft) long hand-held tagline to the end of both counterweight straps so the straps can be guided around the crane during fixed mast raising.

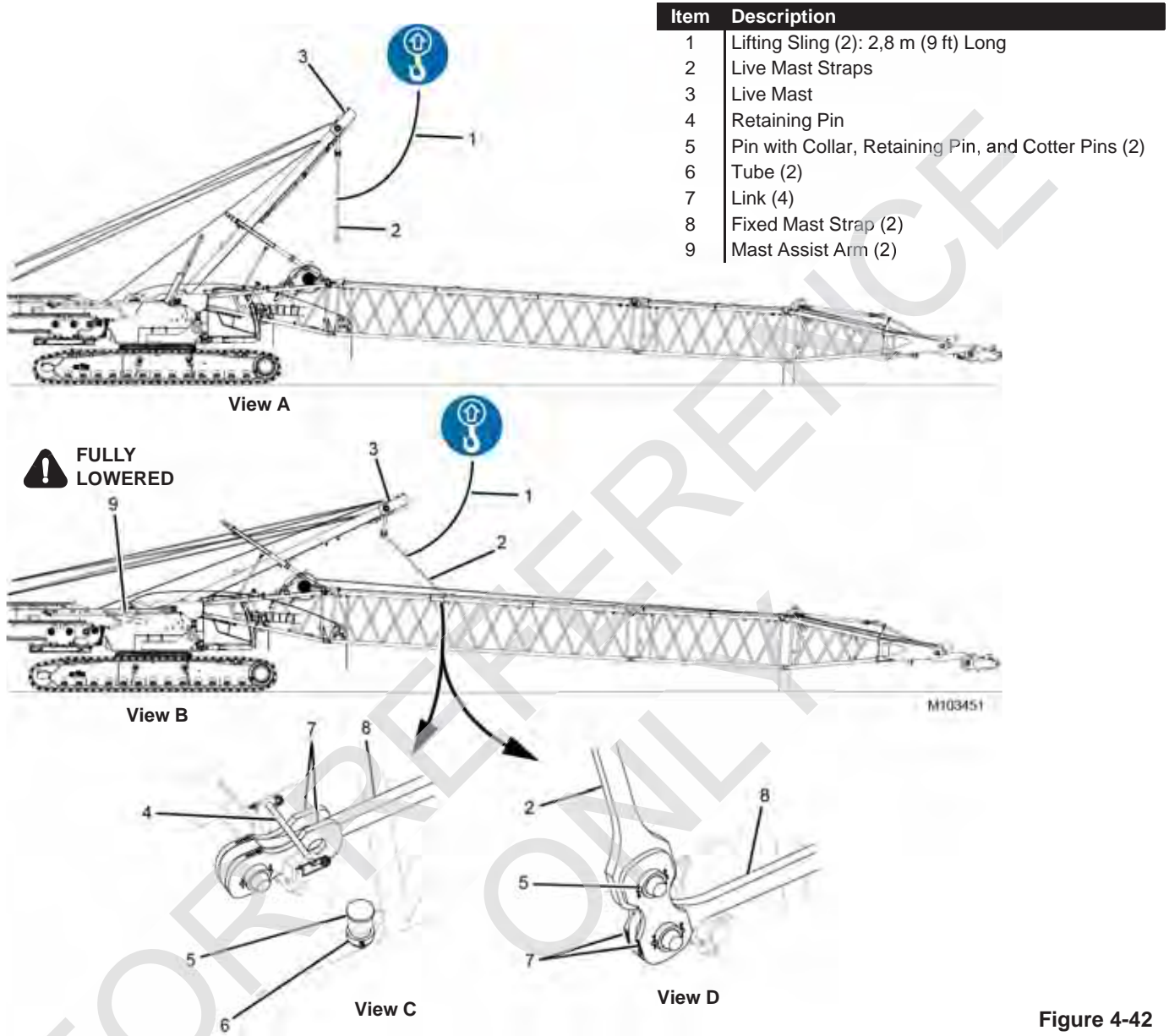

Figure 4-42

Connect Live Mast Straps to Fixed Mast

See [Figure 4-42](#) for the following procedure.

- Using a choker hitch, connect lifting slings (1, View A) to the mast straps (2).
- While following with the assist crane, lower the live mast (3) and lift the mast straps until the live mast is at approximately 154° as shown in View B.
- If not already done, remove the retaining pins (4, View C) and store them in the bracket on the end of the 12 m insert.
- Remove the pins (5, View D) from storage.
- Rotate the links (7, View C) up and pin them to the live mast straps (2, View D) with the pins (5).
- Repeat [step 4](#) and [step 5](#) for the strap on both sides of the 12 m mast insert.
- Disconnect the lifting slings from the live mast straps.

Lower Live Mast Assist Arms



DANGER

Falling Mast Hazard!

Prevent the live mast from falling:

- Fully lower the mast assist arms before raising the live mast. The live mast can buckle and collapse if it contacts the mast assist arms with a fully rigged fixed mast.

Using the switch on the remote control or on the right control console, fully LOWER the mast assist arms (9, View B).

NOTE The following will occur if you attempt to raise the live mast when the mast assist arms are up:

- The mast hoist will not operate.
- The hazard warning will come on and the MAST ASSIST ARMS UP icon will appear in the fault bar of the Main Display Working Screen.
- Make sure the mast assist arms are down before raising the live mast.



Configure Fixed Mast in RCL/RCI Display

Enter the Fixed Mast Configuration in the RCL/RCI Display. Refer to the RCL/RCI Operation Manual for instructions.

Once the fixed mast configuration is entered, the drum handles will control the operations listed in [Figure 4-43](#).

Handle	Controls
A	Drum 4 for raising and lowering the live mast and the fixed mast (using fixed mast as a boom)
B	Drum 1
C	Not used
D	Drum 5 for hauling in and paying out the boom hoist equalizer (using as a load hoist).
NOTE	Handle D controls Drums 6, 2, 3, 5 (in that priority) depending on the combination of parked and un-parked drums

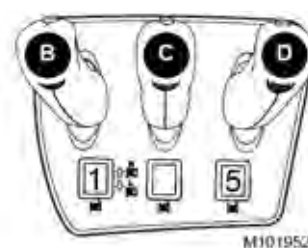
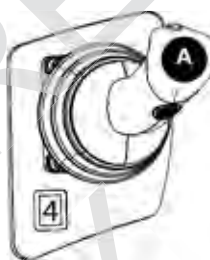

Figure 4-43

FOR REFERENCE ONLY

FOR REFERENCE ONLY

THIS PAGE INTENTIONALLY LEFT BLANK

FIXED MAST RAISING METHODS

There are two fixed mast raising methods:

Preferred Method using Boom Holdback

For this method, all of the procedures and steps given on [page 4-73](#) through [page 4-85](#) must be performed. In general for this method:

- The crane counterweight is installed, BEFORE the #503 fixed mast is used as a boom and before the fixed mast is raised to the VPC-MAX operating position.
- The fixed mast is used as a boom to assemble and install the partial #500 boom.
- An assist crane is used to attach and assemble the remaining #500 boom.
- The boom hoist equalizer is connected to the boom straps (boom is used as holdback).
- The fixed mast is raised to the VPC-MAX operating position.
- The fixed mast and beam positions are adjusted.
- The boom is raised.

Alternate Method using Anchor Holdback

For this method, all of the procedures and steps given on [page 4-86](#) through [page 4-91](#) must be performed. In general for this method:

- The #503 fixed mast is anchored to a holdback weight.

- The fixed mast is raised to the VPC-MAX operating position.
- An assist crane is used to attach and assemble the #500 boom.
- The boom hoist equalizer is placed on the equalizer rails.
- The boom hoist equalizer is connected to the boom straps.
- The crane counterweight is installed, AFTER the fixed mast is raised the VPC-MAX operating position and the boom is installed.
- The fixed mast and beam positions are adjusted.
- The boom is raised.

TARGET TENSION DURING FIXED MAST RAISING AND LOWERING

During mast raising and lowering, the crane control system monitors mast tension (right side only) and automatically slows down either Drum 4 or Drum 5 to maintain the constant target tension specified in the following table:

Type of Fixed Mast Stops	Target Tension
Passive (no hydraulic lines to fixed mast stop cylinders)	18,1 ± 2,0 t (39,900 ± 4,400 lb)
Active (two hydraulic lines to each fixed mast stop cylinder)	21,6 ± 2,0 t (47,600 ± 4,400 lb)

Mast tension can be monitored in the Crane Status Bar of the Main Display (see View E, [Figure 4-44 on page 4-72](#)).

Item	Description
1	Lifting Sling (4): 2,8 m (9 ft) Long
2	Lifting Lug (4)
3	Boom Hoist Equalizer
4	Retaining Pin with Snap Pin (2)
5	Shipping Rail (2)
6	Fixed Mast Top
7	Fixed Mast Angle
8	RCL/RCI Display
9	Mast Tension
10	Main Display
11	Shackle (2): 25 t (28 USt)

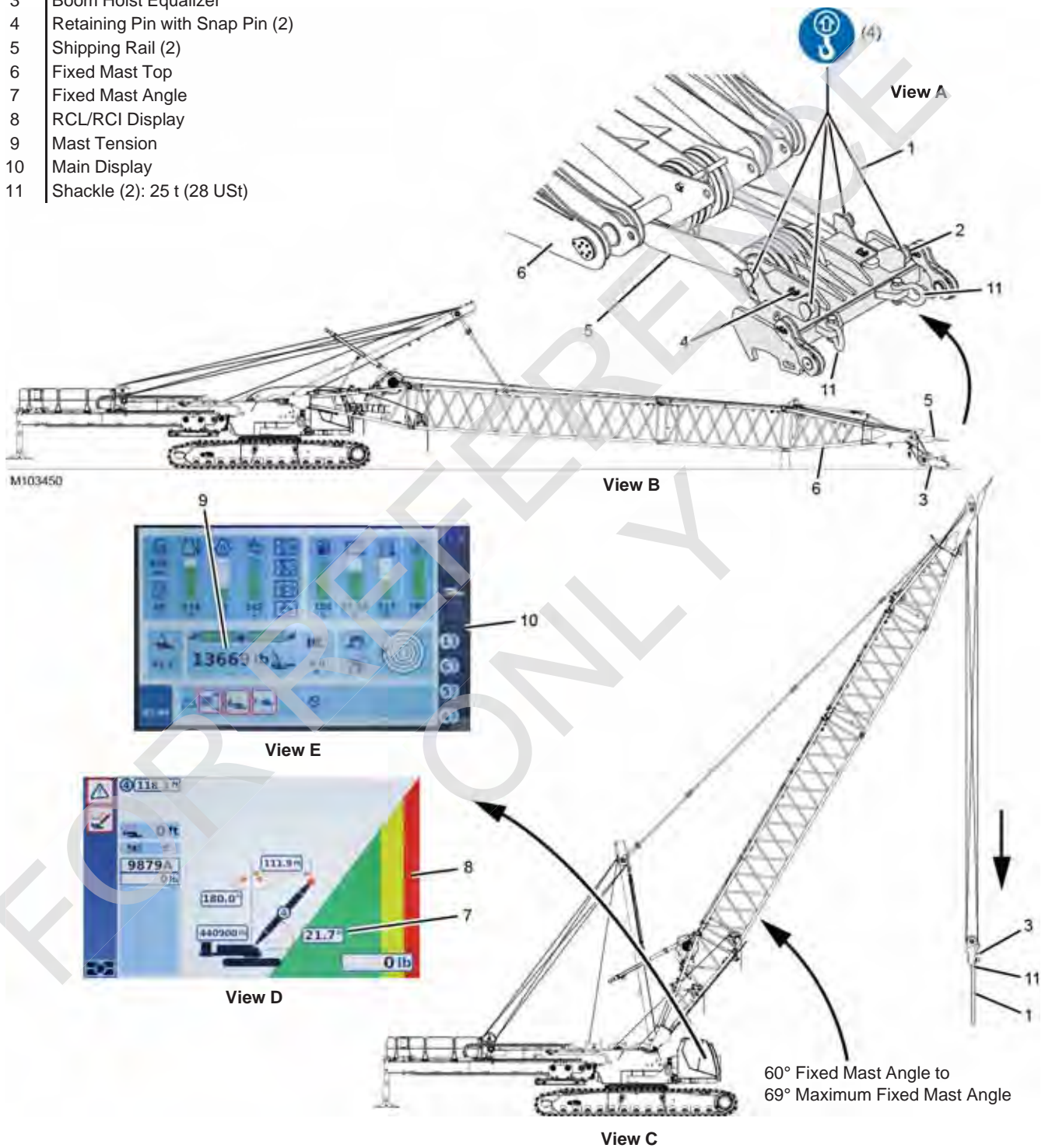

Figure 4-44

RAISING FIXED MAST — PREFERRED METHOD WITH BOOM HOLDBACK

Disconnect Boom Hoist Equalizer from Mast Top

See [Figure 4-44](#) for the following procedure.

1. Attach the lifting slings (1, View A) to the lifting lugs (2) on the boom hoist equalizer (3) and to the hook of the assist crane.
2. Hoist with the assist crane so the lifting slings start to tighten.
3. Remove the retaining pins (4, View A) connecting the boom hoist equalizer (3) to the shipping rails (5) on the mast top (6).
4. Lift the boom hoist equalizer off the shipping rails (5, View A) while paying out the boom hoist wire rope from Drum 5.
5. Place the boom hoist equalizer (3, View B) on the ground directly under the shipping rails (5).
6. Disconnect the lifting slings from the boom hoist equalizer.
7. Install the retaining pins (4, View A) in the holes in the boom hoist equalizer (3).

Raise Fixed Mast to Boom Rigging Position

See [Figure 4-44](#) for the following procedure.

1. Verify that the mast assist arms are fully lowered. See [Lower Live Mast Assist Arms on page 4-69](#).



DANGER

Falling Mast Hazard!

Prevent the mast from falling:

- Fully lower the mast assist arms before raising the fixed mast. The live mast can buckle and collapse if it contacts the mast assist arms with a fully rigged fixed mast.

2. Verify that all mast strap and counterweight strap shipping pins are removed and stored.

CAUTION

Mast Damage!

Avoid fixed mast or boom hoist equalizer damage. Do not raise fixed mast until all straps are unpinned from mast strap brackets.

3. Perform the following pre-raising steps and correct any defects before raising the fixed mast.

- Crane on firm, level surface.
- Fixed mast inserts installed in proper sequence.
- Fixed mast and counterweight straps pinned in working position.
- All straps unpinned from fixed mast strap brackets.
- All insert connector pins installed and properly retained.
- Fixed mast configuration selected in RCL/RCI display.
- Live mast arms fully lowered.
- All blocking, tools, and other items removed from fixed mast.
- Mast hoist and boom hoist wire rope spooled tightly onto drums and engaged with proper sheaves.
- Wind within allowable limits for operation.

4. Slowly mast up using the Drum 4 control handle to raise the fixed mast until the boom hoist equalizer is hanging freely from the end of the fixed mast.
5. Continue to mast up (View C) while lowering the boom hoist equalizer with the Drum 5 control handle.
6. Stop raising the fixed mast when it is in the boom rigging range: 60-69°.

The live mast angle (7, View D) can be monitored in the Crane Status Bar of the Main Display (8).

7. Attach two shackles (11, View A) and four lifting slings (1, View C) to the boom hoist equalizer (3).
8. Park Drums 4 and 5.



WARNING

Falling Mast/Tipping Hazard!

Prevent the mast from falling:

- Do not raise the fixed mast higher than 69°, with or without counterweight installed, until after the boom is attached to the crane and the boom hoist equalizer is attached to the boom straps.
- The mast could fall over backwards or the crane could tip if this precaution is ignored.

See [Figure 4-46 on page 4-76](#)

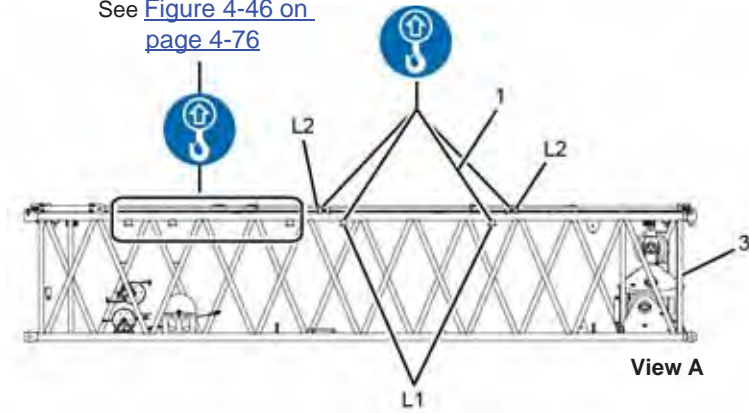

Item	Description
1	Lifting Sling (4): 2,8 m (9 ft) Long
2	Boom Butt
3	12 m Boom Insert with Wire Rope Guides
4	12 m Boom Insert with Equalizer Rails
5	Boom Stop (2)
6	Wire Rope Guide
7	Strap (4)
L1	Lifting Lugs (4) for Lifting only the 12 m Boom Section with Synthetic Lifting Slings
L2	Lifting Lugs (4) for Lifting only the 12 m Boom Insert with Hooked Lifting Chains or Synthetic Lifting Slings with Shackles
*	See MLC300 Crane Operator Manual for Lifting Lug Identification

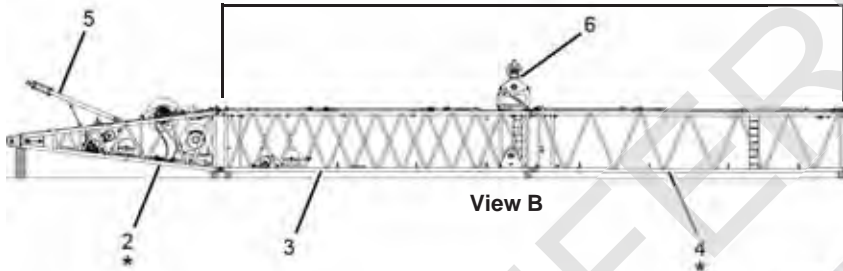

NOTE These inserts can be either standard width inserts OR 3,5 m wide inserts, depending on the Boom Rigging Drawing being used.

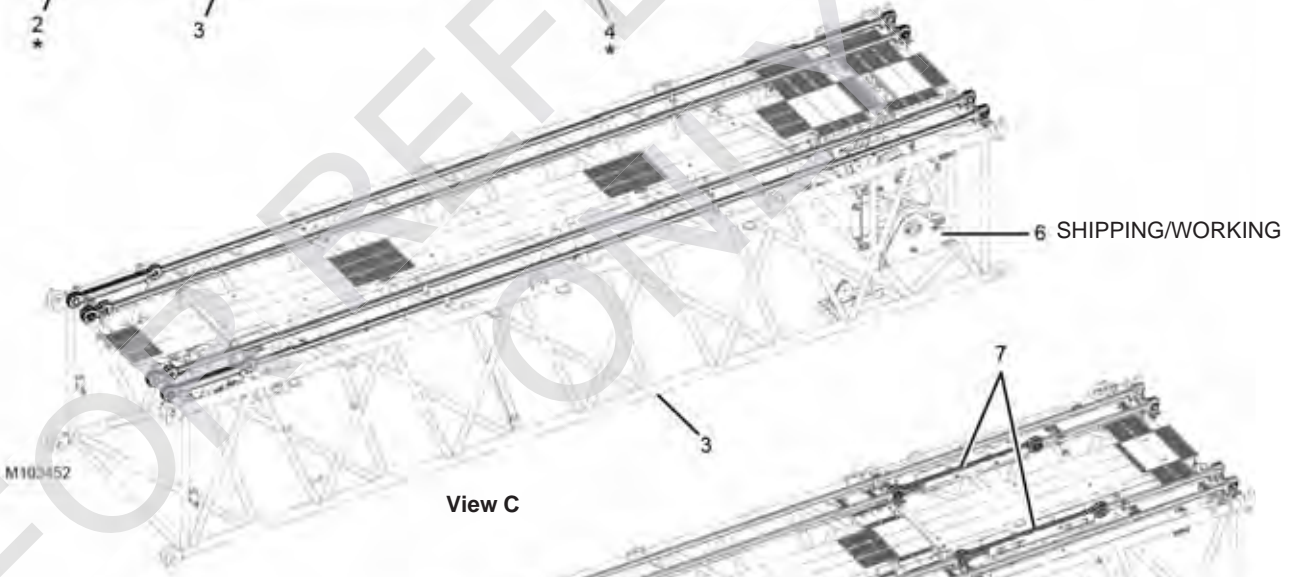

M103452

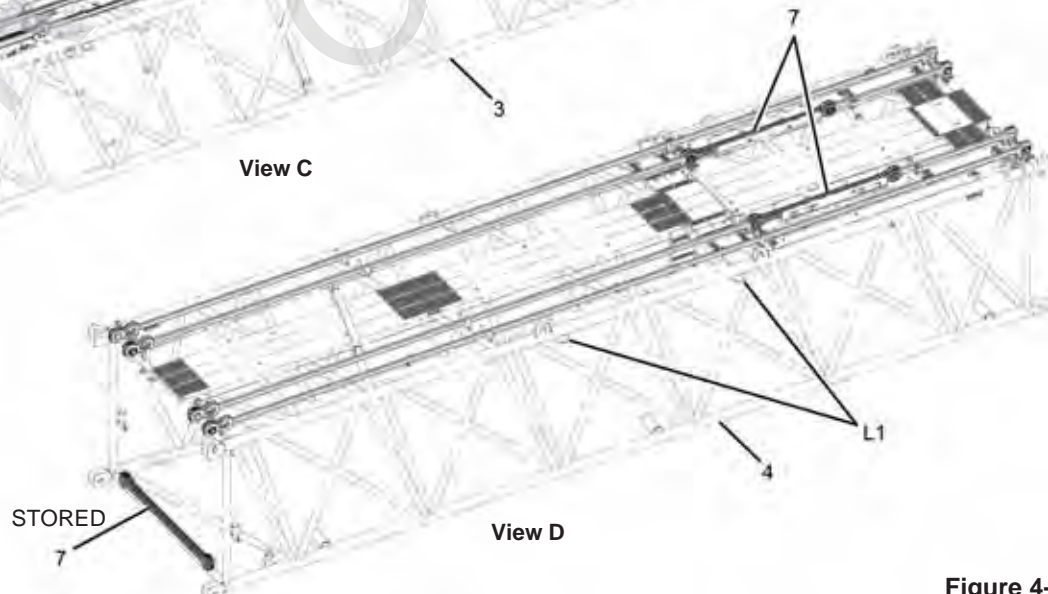

Figure 4-45

**WARNING****Tipping Hazard!**

Prevent the crane from tipping:

- Do not attempt to use the fixed mast as a boom until the crane counterweight is installed.
- The crane could tip forward if this precaution is ignored.

Install Counterweight Boxes

- See the Install Counterweight Boxes topic in Section 4 of the Crane Operator Manual for detailed instructions.
- Make sure the counterweight tray is at the minimum position as instructed on [page 4-49](#) of this section.

Assemble Partial Boom

The partial boom can be assembled with the fixed mast or with an assist crane.

See [Figure 4-45](#) for the following procedure.

NOTE The following procedure assumes the assemblers are already thoroughly familiar with the MLC300 and the boom assembly procedures in the MLC300 Crane Operator Manual.

1. Refer to View A for identification of the lifting lugs on the 12 m insert (3).
2. Prepare the boom butt (2), as follows:
 - Raise the boom stops (5, View B).
3. Prepare the 12 m boom insert (3, View C) as follows:
 - If Drums 2, 3, or 6 will be used, move the wire rope guide (6) from inside the 12 m insert (3) to the top of the 12 m insert.
 - If only Drum 1 will be used, the wire rope guide can remain inside the boom insert.
 - The boom and luffing jib straps can be left in the stored position on top of the insert as shown in View C. **Make sure the storage pins and links are installed and secured.**
4. Prepare the 12 m boom insert (4, View D) as follows:
 - Remove the straps (7) from the shipping/working position and store them on the end of the insert.
 - The boom and luffing jib straps can be left in the stored position on top of the insert as shown in View D. **Make sure the storage pins and links are installed and secured.**
5. Assemble the boom butt (2, View B), the 12 m insert (3), and the 12 m insert (4).
 - The inserts must be assembled in the sequence shown. Refer to the Boom Rigging drawing at the end of this section.

Item	Description
1	Live Mast
2	Fixed Mast
3a	Shackle: 25 t (28 USt)
3b	Shackle: 20.5 t (23 USt)
4a	Lifting Sling: 2,8 m (9 ft) Long
4b	Lifting Sling: 4 m (13 ft) Long
5	Boom Hoist Equalizer
6	12 m Boom Insert with Wire Rope Guides
7	Boom Butt
8	12 m Boom Insert with Equalizer Rails
9	Blocking: 330 mm (13 in) high
SLP	Sling Lifting Post

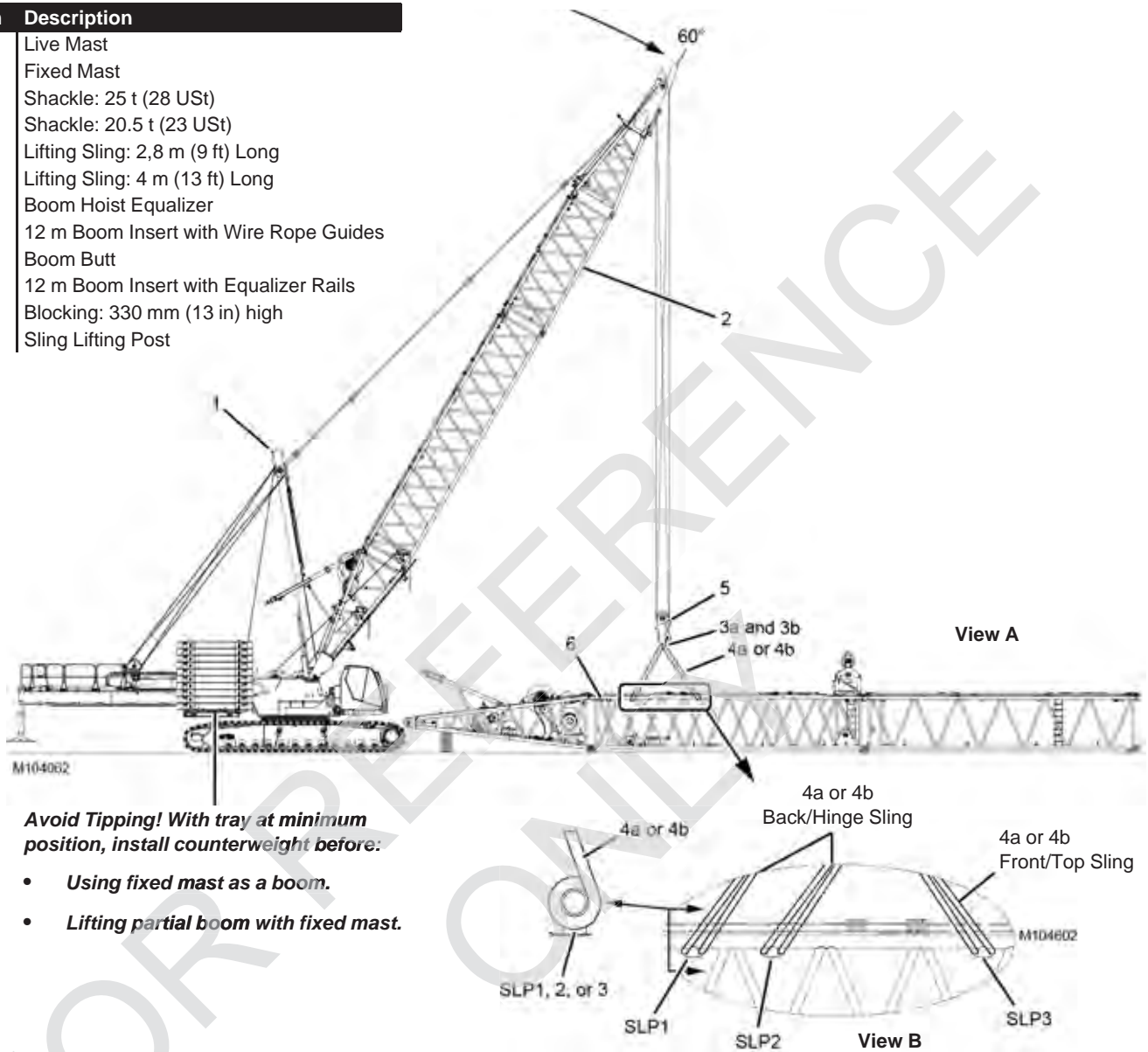

Partial Boom Lifting Table

Insert Configuration	Qty 4 Sling Item No.	Item 3a	Back/Hinge Sling						Front/Top Sling			
			SLP Item No.	Left		Right		SLP Item No.	Left		Right	
				Item 3b	Wrap on Chord	Item 3b	Wrap on Chord		Item 3b	Wrap on Chord	Item 3b	Wrap on Chord
with Luffing Jib Backstay Straps and with Drum 6	4a	2	1	0	0	0	0	3	1	0	0	0
	4b	2	1	0	0	0	0	3	1	0	0	0
without Luffing Jib Backstay Straps and with Drum 6	4a	2	1	1	1	1	1	3	1	0	0	0
	4b	2	1	0	0	0	0	3	2	0	1	0
without Luffing Jib Backstay Straps and without Drum 6	4a	2	2	0	0	0	0	3	0	0	0	0
	4b	2	2	0	0	0	0	3	0	0	0	0

Figure 4-46

Install Partial Boom

See [Figure 4-46](#) for the following procedure.

! WARNING
Tipping Hazard!

Prevent the crane from tipping:

- Do not attempt to lift the partial boom with the fixed mast until the crane counterweight is installed.
- The crane could tip forward if this precaution is ignored.

1. Position the crane in line with the boom as shown in View A:
 - Lower the live mast (1, View A) so the fixed mast (2) is at approximately 60°.
 - To ensure the partial boom lifts level, attach the shackles (3a and 3b) and four lifting slings (4a or 4b)

to the equalizer (5) and the appropriate posts (SLP1, 2, or 3, View B) on the 12 m boom insert (6).
See the Partial Boom Lifting Table.

See View A, [Figure 4-44 on page 4-72](#) for the shackle attachment locations on the equalizer.

2. Haul in the boom hoist wire rope to lift the partial boom clear of the ground.
3. Slowly raise the live mast and payout or haul in the boom hoist wire rope to position the boom butt (7, View C) near the connecting lugs in the boom butt.
4. Connect the boom butt to the crane as instructed in Section 4 of the MLC300 Crane Operator Manual.
5. Lower the partial boom onto blocking (9, View C) 330 mm (13 in) high under the 12 m insert (8) connectors.
6. Disconnect the lifting slings from the 12 m insert (6).
7. Disconnect and store the hydraulic hoses for the boom hinge pins, as instructed in Section 4 of the MLC300 Crane Operator Manual.

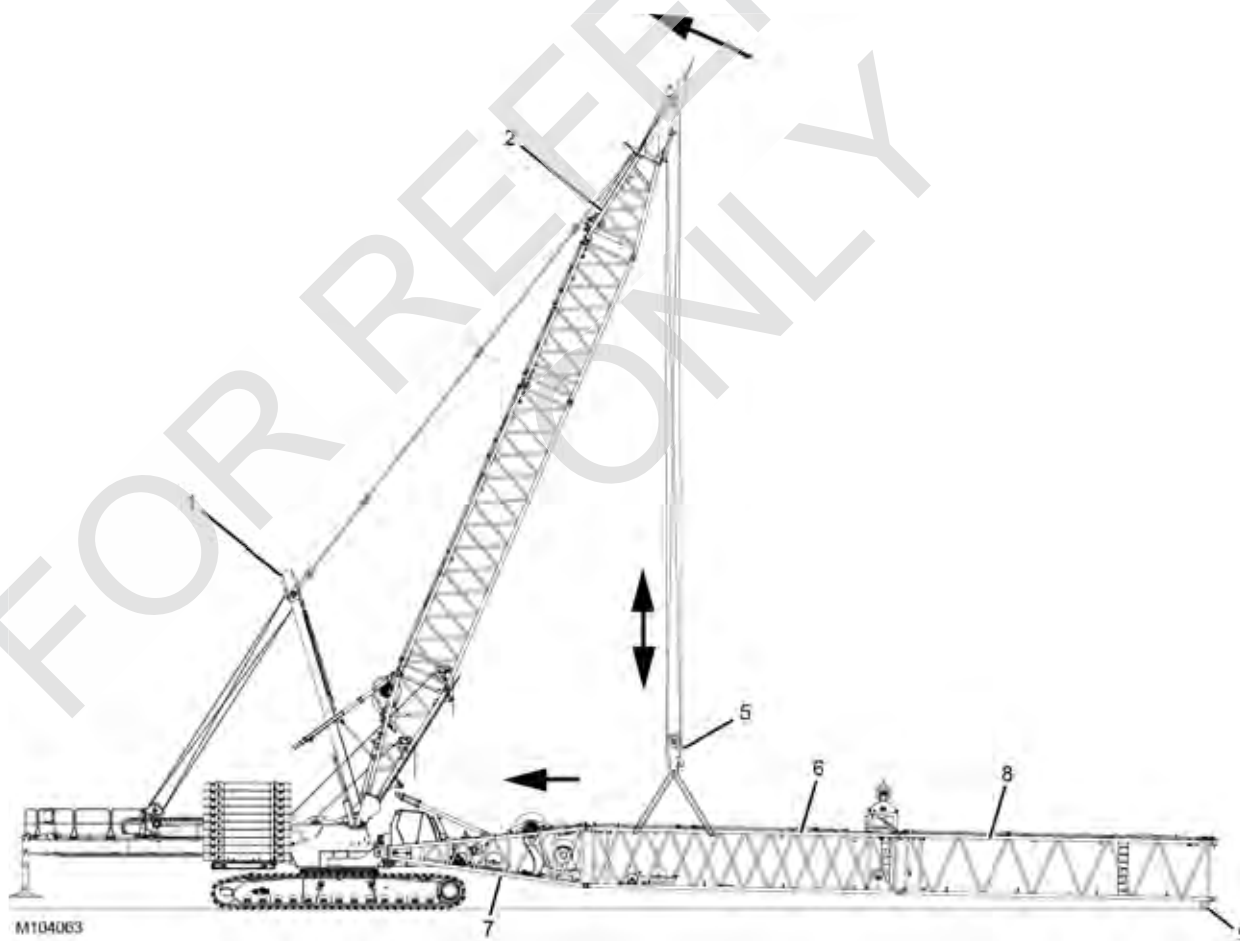

View C

Figure 4-46 continued

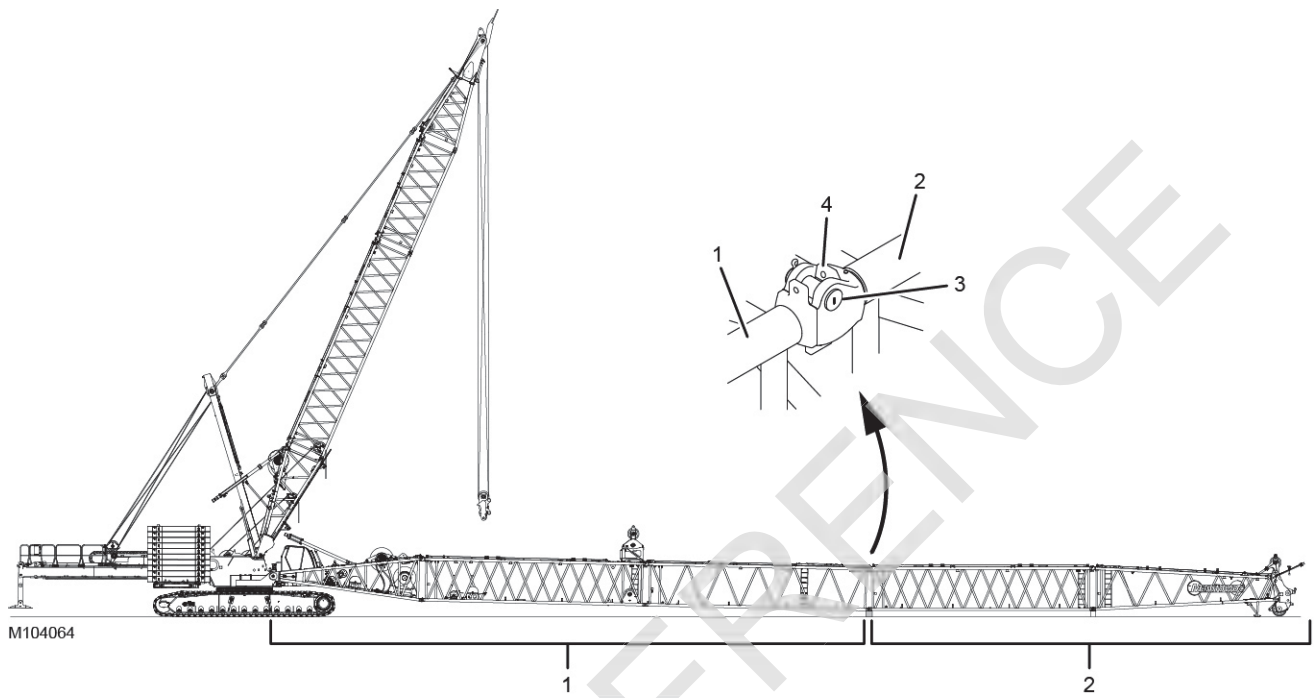

M104064

Assembled in Proper Sequence According to the Boom Rigging Drawing

Item	Description
1	Partial Boom
2	Remaining Boom Sections (inserts and top)
3	Fixed Horizontal Pin (2)
4	Hooked Connector (2)

Figure 4-47

Assemble Remaining Boom Sections

See [Figure 4-47](#) for the following procedure.

Using an assist crane, assemble the remaining boom sections (2) to the end of the partial boom (1).

- See the Assemble Boom Inserts and Top topic in Section 4 of the Crane Operator Manual for detailed instructions.

- The inserts must be assembled in the sequence shown in the Boom Rigging Drawing at the end of this section.

Connect Boom Straps

Starting at the boom top connect the boom straps between all of the boom sections, to include the 1,69 m (5.5 ft) straps on the 12 m (39.4 ft) insert with boom hoist equalizer rails.

- See the Connect Boom Straps topic in Section 4 of the Crane Operator Manual for detailed instructions.

FOR REFERENCE ONLY

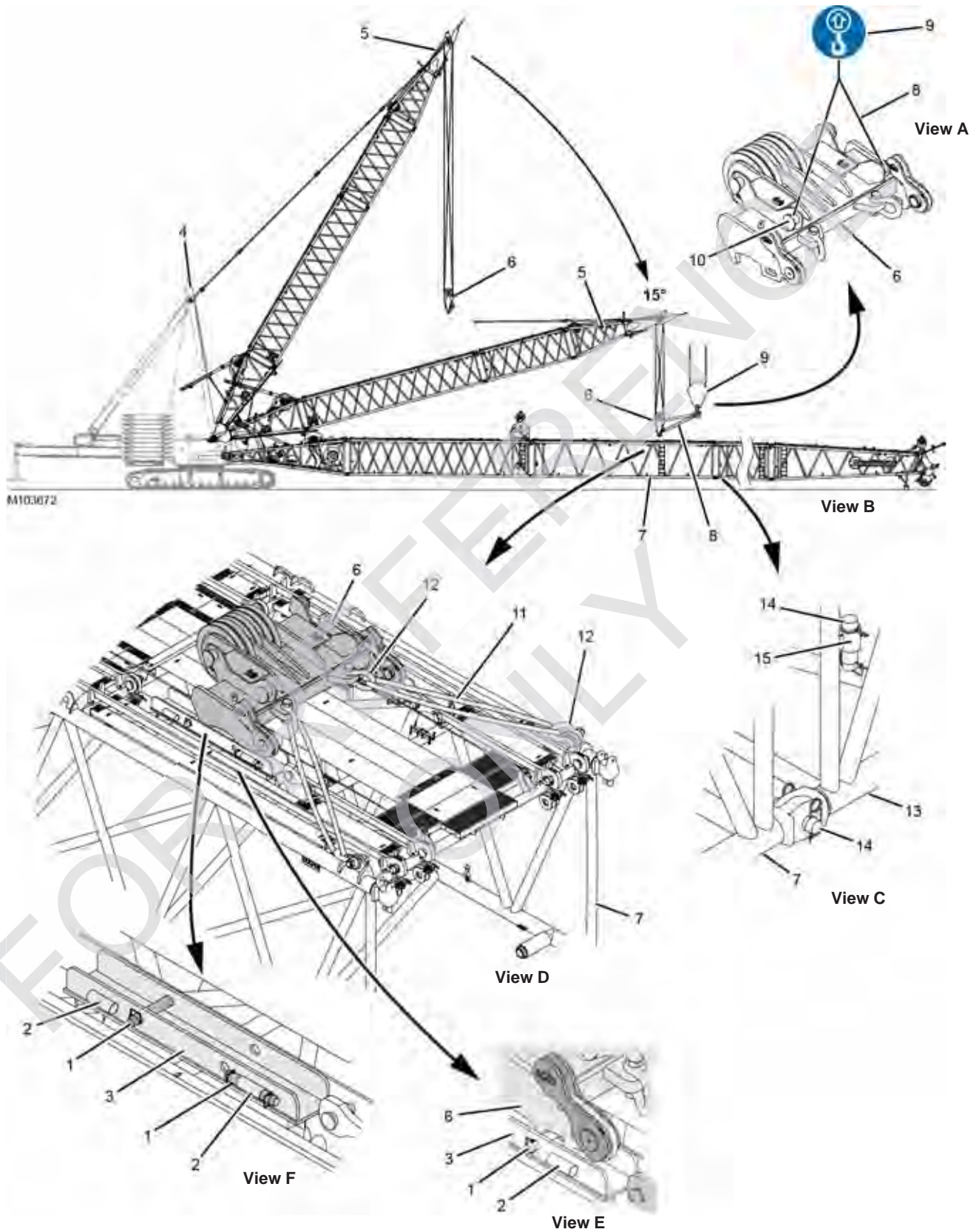

Figure 4-48

Legend for [Figure 4-48](#)

Item	Description
1	Stop Pin with Safety Pins (4)
2	Storage Tube (4)
3	Rails (2 sets)
4	Live Mast
5	Fixed Mast
6	Boom Hoist Equalizer
7	12 m Insert (with equalizer rails)
8	Synthetic Lifting Sling (2): 2,8 m (9 ft)
9	Assist Crane Hook
10	Lifting Lug (front 2)
11	Synthetic Lifting Sling (2): 1,87 m (6.1 ft)
12	Shackle (4)
13	Adjacent Insert
14	Pin with Safety Pin (2)
15	Storage Tube (2)

Connect Boom Sections

See [Figure 4-48](#) for the following procedure.

1. Remove the rear stop pins (1, View F) from the rear storage tubes (2) and install the pins in the rear holes of the boom hoist equalizer rails (3).
2. Leave the front stop pins (1, View F) stored in the front storage lugs (2).

CAUTION Mast Damage!

Do not allow the fixed mast to contact Drum 1 in the boom butt during the following steps. Damage to the fixed mast and/or drum could result.

3. Pay out the mast hoist wire rope to lower the masts (4 and 5, View B).
4. At the same time, haul in the boom hoist wire rope to raise the boom hoist equalizer (6).
5. Stop lowering the masts when:
 - The fixed mast (5, View B) is at approximately 15°.
 - The boom hoist equalizer (6, View B) is hanging just to the rear the rails 12 m insert (7) as shown.
6. Connect two synthetic lifting slings (8, View A) to the hook of the assist crane (9) and to lifting lugs (10) on the boom hoist equalizer (6).
7. Slowly lift the boom hoist equalizer with the assist crane until the boom hoist equalizer is horizontal as shown in View A.
8. Slowly pay out the boom hoist wire rope from the MLC300 and lower the boom hoist equalizer (6) with the

assist crane until the boom hoist equalizer is resting on the rails (3, View D).

9. Make sure the boom hoist equalizer is on the forward side of the rear stop pins (1, View F).
10. Slacken the boom hoist wire rope and the synthetic lifting slings so the equalizer cannot slide rearward.
11. Disconnect the synthetic lifting slings (8, View A) from the boom hoist equalizer (6).
12. Connect two synthetic lifting slings (11, View D) between the shackles (12) on the boom hoist equalizer (6) and the 12 m insert (7).
13. Slowly haul in the boom hoist wire rope on the MLC300 until the boom hoist equalizer (6, View D) is out of the rails (3) and the synthetic lifting slings (11) are tight.

CAUTION

Boom or Mast Damage!

Do not attempt to lift the entire boom during the following step. Damage to the fixed mast and/or boom could result. Do not exceed a mast strap tension of 155 t (342,000 lb) — 77,6 t (171,000 lb) per strap. Mast strap tension can be monitored in the Crane Status Bar of the Main Display (View E, [Figure 4-44 on page 4-72](#)).

14. Slowly continue to haul in the boom hoist wire rope to raise the boom sections until the bottom connecting holes are aligned between the 12 m insert (7, View C) and the adjacent insert (13).
15. Remove the pins (14, View C) from the storage tubes (15) and install the pins in the bottom connecting holes.
16. Slowly pay out the boom hoist wire rope until the boom hoist equalizer is resting on the rails (3, View D) and the synthetic lifting slings (11) are slack.
17. Remove the front stop pins (1, View F) from the front storage tubes (2) and install the front stop pins (1, View E) in the front holes of the boom hoist equalizer rails (3) and the boom hoist equalizer (6).
18. Disconnect the synthetic lifting slings (11, View D) from between the shackles (12) on the boom hoist equalizer (6) and the 12 m insert (7).
19. Store the lifting slings. The shackles (12) can remain attached to the boom hoist equalizer (6) and the 12 m insert (7).

Finish Assembling Boom

Make sure all of the steps are performed under the topic Boom #500 Assembly in Section 4 of the Crane Operator Manual.

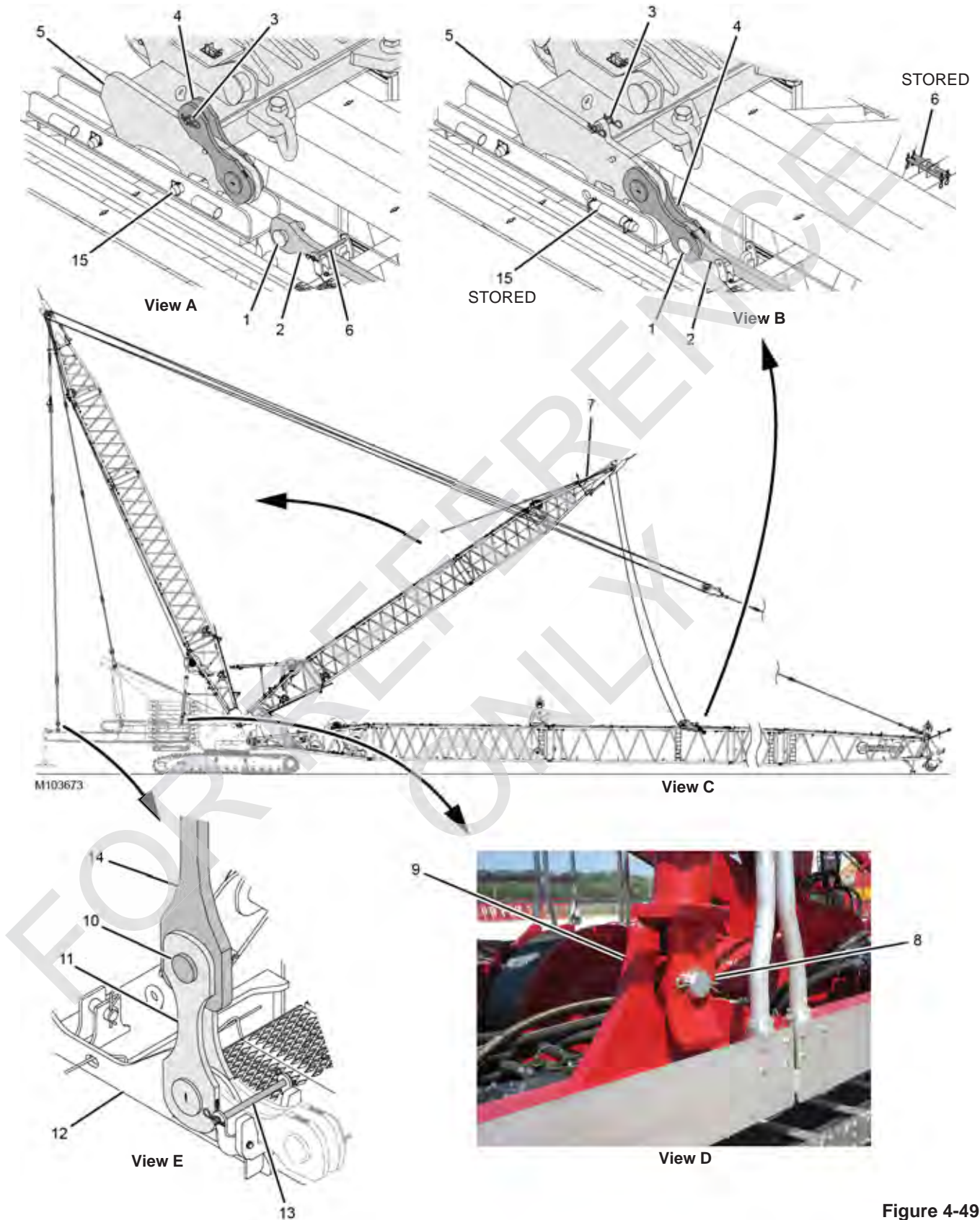

Figure 4-49

Legend for [Figure 4-49](#)

Item	Description
1	Pin with Collar, Retaining Pin, and Cotter Pins (2)
2	Boom Strap (2)
3	Pin with Hair-Pin Cotters (2)
4	Equalizer Links (4)
5	Boom Hoist Equalizer
6	Pins with Hair-Pin Cotters (2)
7	Fixed Mast
8	Mast Stop (2)
9	Mast Stop Lug (2)
10	Pin with Collar, Retaining Pin, and Cotter Pins (2)
11	Counterweight Links (4)
12	VPC-MAX Beam
13	Pin with Hair-Pins Cotters
14	Counterweight Strap (2)
15	Front Stop Pin with Safety Pins (2)

Connect Equalizer Links to Boom Straps

See [Figure 4-49](#) for the following procedure.

1. Remove the pins (1, View A) from the boom straps (2).
2. Remove the pins (3, View A) and rotate the equalizer links (4) forward.
3. Pin the equalizer links (4, View B) to the boom straps (2) with pins (1).
4. Reinstall the pins (3, View B) in the boom hoist equalizer (4) holes.
5. Remove the pins (6, View A) and store them (View B).

Raise Fixed Mast to Operating Position

See [Figure 4-49](#) for the following procedure.

1. Perform the following checks before starting:
 - All boom straps unpinned from strap brackets.
 - Equalizer links pinned to straps on 12 m insert.
 - Boom straps unpinned from 12 m insert (with rails).
 - Boom hoist equalizer unpinned from rails.
 - Wind within allowable limits for operation.

CAUTION

Structural Damage!

Do not raise fixed mast until boom hoist equalizer is unpinned from rails and boom straps are unpinned from strap brackets.

2. Remove the front stop pins (15, View A) and store them (View B).
3. Slowly raise the fixed mast (7) while paying out the boom hoist wire rope.

- The operator must match the rate of speed at which the mast hoist wire rope is hauled in with the rate of speed at which the boom hoist wire rope is payed out.
- **The boom hoist wire rope must remain slack until the fixed mast nears vertical.**
- Use care not to allow the boom hoist equalizer and straps to bounce up and down against the boom sections.

4. As the fixed mast nears vertical, tighten the boom hoist wire rope as required so the fixed mast moves smoothly past vertical to the rear.

NOTE: As the fixed mast lowers, use the hand-held taglines to guide the counterweight straps clear of the live mast. **Damage can occur if this step is not performed.**

5. Continue to slowly haul in the mast hoist wire rope and pay out the boom hoist wire rope to lower the fixed mast to the rear.

NOTE As the fixed mast lowers, the crane control system monitors mast tension and automatically slows down either Drum 4 or Drum 5 to maintain the constant target tension specified on [page 4-71](#).

The mast tension can be monitored in the Crane Status Bar of the Main Display (see View E, [Figure 4-44 on page 4-72](#)).

6. Just prior to engagement between the mast stops (8, View D) and the mast stop lugs (9), stop lowering the fixed mast and confirm alignment.
7. Continue to lower the fixed mast. Stop lowering when the fixed mast stops (8, View D) come to rest in the mast stop lugs (9) on rotating bed.
8. Continue to slowly haul in mast hoist wire rope and pay out boom hoist wire rope so the counterweight straps can be connected to the counterweight links.
9. Connect the counterweight straps to the counterweight links, as follows (see View E):
 - a. Remove the pins (10) from the counterweight links (11) on the VPC-MAX beam (12).
 - b. Remove the pins (13) and rotate the counterweight links (11) to vertical.
 - c. Install pins (10) to connect the counterweight links (11) the counterweight straps (14). Repeat [step 8](#) as necessary to align the holes.
 - d. Reinstall the pins (13) in the strap brackets on the VPC-MAX beam (12).
10. Remove all hand-held taglines.

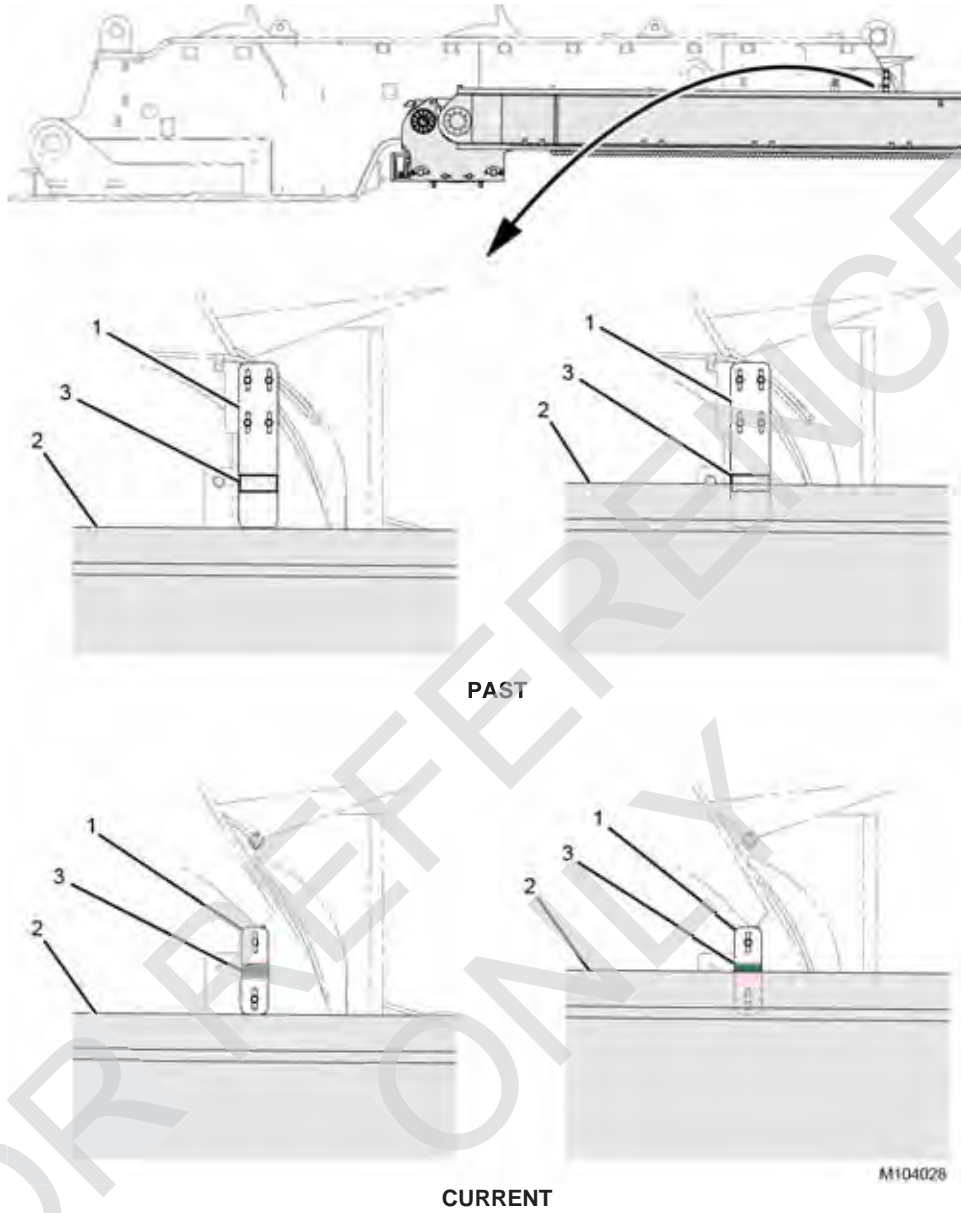

Item	Description
1	Height Gauge
2	Beam (left side)
3	Height Decal

Figure 4-50

**WARNING****Structural Damage Hazard!**

Do not operate the crane unless the VPC-MAX beam position is properly adjusted.

Operating the crane with a VPC-MAX beam that is not properly adjusted could cause structural damage to the rotating bed and/or the VPC-MAX beam due to interference of the beam hooks and the rotating bed pins.

Adjust Fixed Mast and Beam Position

See [Figure 4-50](#) for the following procedure:

1. If not already done, turn on the fixed mast configuration in the RCL/RCI display so that Drum 4 and Drum 5 can both be operated.

2. Move the counterweight tray to the minimum working position.

NOTE The beam should still be supported by the beam hooks at this point. The counterweight tray should be at the minimum working position. However, for some boom lengths, partial counterweight may be required to accomplish this procedure.

3. With the beam resting on the hooks, loosen the mounting screws and adjust the position of the height gauge (1) — up or down — so the bottom edge of the gauge is flush with the top edge of the beam (2).

4. Securely tighten the mounting screws.

5. Once the boom is fully assembled and ready to be raised, slowly pay out on Drum 4 and haul in on Drum 5 to raise the beam into position.

NOTE Paying out wire rope from Drum 4 decreases the boom suspension tension. Hauling in wire rope on Drum 5 increases the boom suspension tension.

The crane control system may slow down either Drum 4 or Drum 5 to maintain the constant target tension specified on [page 4-71](#).

The mast tension can be monitored in the Crane Status Bar of the Main Display (see View E, [Figure 4-44 on page 4-72](#)).

6. Make sure the counterweight straps are in tension and the beam hooks have started to rise off the rotating bed pins.

NOTE As the counterweight strap tension increases, the backhitch load changes rapidly.

7. Stop raising the beam when the top edge of the beam is centered in the height decal (3).

Raise Boom

1. Enter the desired boom or jib configuration in the RCL/RCI display.

2. The boom can now be raised:

- Perform "[Pre-Raising Checks](#)" on [page 4-92](#)
- See "[Boom Raising Procedure](#)" on [page 4-93](#)

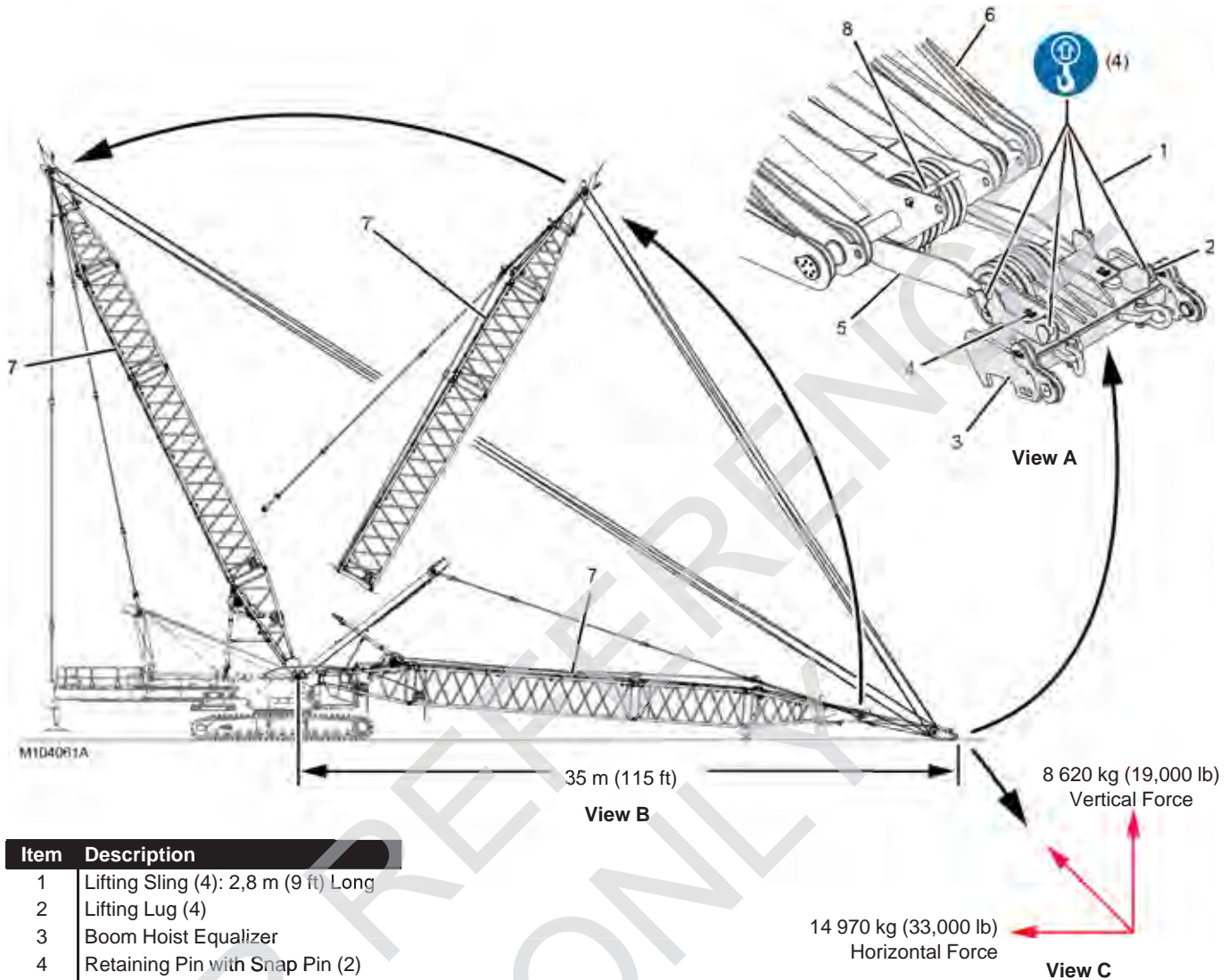

Item	Description
1	Lifting Sling (4): 2,8 m (9 ft) Long
2	Lifting Lug (4)
3	Boom Hoist Equalizer
4	Retaining Pin with Snap Pin (2)
5	Shipping Rail (2)
6	Fixed Mast Top
7	Fixed Mast
8	Rope Guard

Figure 4-51

RAISING FIXED MAST — ALTERNATE METHOD WITH ANCHORED HOLDBACK

Disconnect Boom Hoist Equalizer from Mast Top

See [Figure 4-51](#), View A for the following procedure.

1. Attach the lifting slings (1, View A) to the lifting lugs (2) on the boom hoist equalizer (3) and to the hook of the assist crane.
2. Hoist with the assist crane so the lifting slings start to tighten.

3. Remove the retaining pins (4, View A) connecting the boom hoist equalizer (3) to the shipping rails (5) on the fixed mast top (6).
4. Lift the boom hoist equalizer off the shipping rails (5, View A) while paying out the boom hoist wire rope from Drum 5.
5. Place the boom hoist equalizer (3, View B) on the ground at the specified dimension.
6. Disconnect the lifting slings from the boom hoist equalizer.
7. Install the retaining pins (4, View A) in the holes in the boom hoist equalizer (3).

Anchor Boom Hoist Equalizer to Holdback

Anchor the boom hoist equalizer (3) to the desired holdback per the anchor holdback diagram in [Figure 4-51](#), View C.

Raise Fixed Mast

See [Figure 4-51](#) for the following procedure.

1. Verify that the mast assist arms are fully lowered. See [Lower Live Mast Assist Arms on page 4-69](#).



DANGER

Falling Mast Hazard!

Prevent the mast from falling:

- Fully lower the live mast assist arms before raising the live mast. The live mast can buckle and collapse if it contacts the mast assist arms with a fully rigged fixed mast.

2. Verify that all mast strap and counterweight strap shipping pins are removed and stored.

CAUTION

Mast Damage!

Avoid fixed mast or boom hoist equalizer damage. Do not raise fixed mast until all straps are unpinned from mast strap brackets.

3. Perform the following pre-raising steps and correct any defects before raising the fixed mast.

- Crane on firm, level surface.
- Counterweight NOT installed.
- Fixed mast inserts installed in proper sequence.
- Fixed mast and counterweight straps pinned in working position.
- All straps unpinned from fixed mast strap brackets.
- All insert connector pins installed and properly retained.
- Fixed mast configuration selected in RCL/RCI display.
- Live mast arms fully lowered.
- All blocking, tools, and other items removed from fixed mast.
- Mast hoist and boom hoist wire rope spooled tightly onto drums and engaged with proper sheaves.

- Wind within allowable limits for operation.



WARNING

Tipping Hazard!

Prevent the crane from tipping:

- Do not raise the fixed mast with counterweight installed. The crane could tip.
 - Install the counterweight after the boom is attached to the crane and the boom hoist equalizer is attached to the boom straps.
4. Slowly raise the fixed mast (7) while paying out the boom hoist wire rope.
 - Keep the boom hoist wire rope slack until the mast is well above horizontal so the wire rope does not rub against the rope guard (8) in the mast top.
 - The operator must match the rate of speed at which the mast hoist wire rope is hauled in with the rate of speed at which the boom hoist wire rope is payed out.
 - **The boom hoist wire rope must remain slack until the fixed mast nears vertical.**
 - Use care not to allow the boom hoist equalizer and straps to bounce up and down against the boom sections.
 5. As the fixed mast nears vertical, tighten the boom hoist wire rope as required so the fixed mast moves smoothly past vertical to the rear.

NOTE: As the fixed mast lowers, use the hand-held taglines to guide the counterweight straps clear of the live mast. **Damage can occur if this step is not performed.**

6. Continue to slowly haul in the mast hoist wire rope and pay out the boom hoist wire rope to lower the fixed mast to the rear.

NOTE As the fixed mast lowers, the crane control system monitors mast tension and automatically slows down either Drum 4 or Drum 5 to maintain the constant target tension specified on [page 4-71](#).

The mast tension can be monitored in the Crane Status Bar of the Main Display (see View E, [Figure 4-44 on page 4-72](#)).

Continued on next page.

Item	Description
1-6	See Figure 4-51 on page 4-86
7	Fixed Mast
8	Mast Stop (2)
9	Mast Stop Lug (2)
10	Pin with Collar, Retaining Pin, and Cotter Pins (2)
11	Counterweight Links (4)
12	VPC-MAX Beam
13	Pin with Hair-Pins Cotters
14	Counterweight Strap (2)

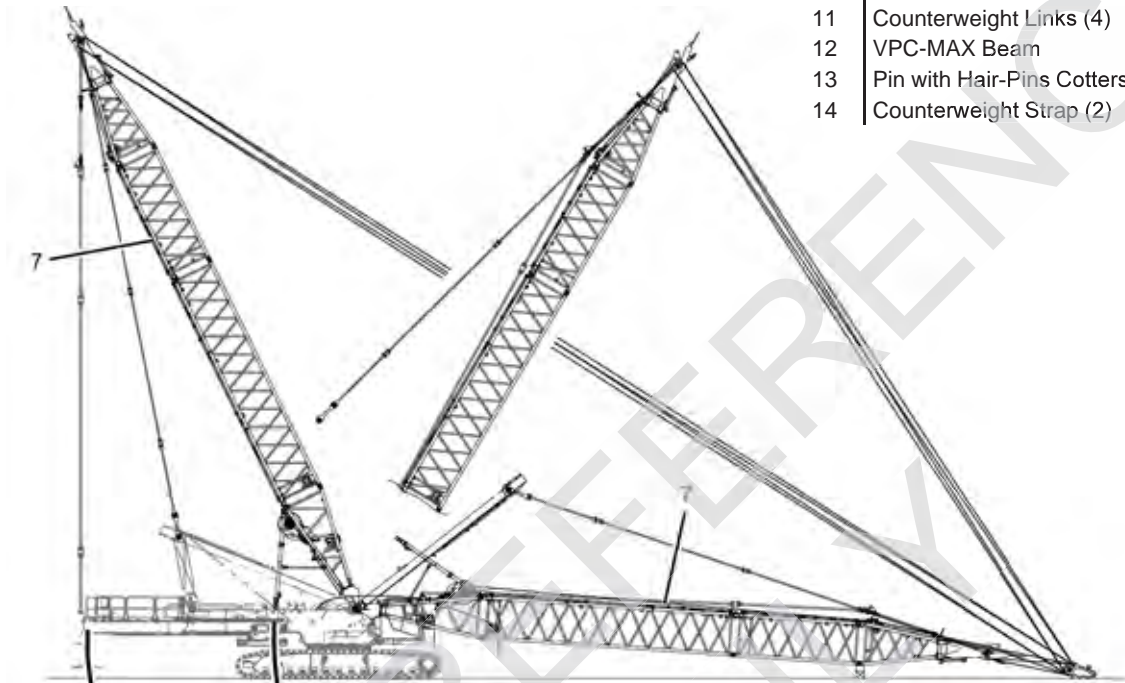

View A

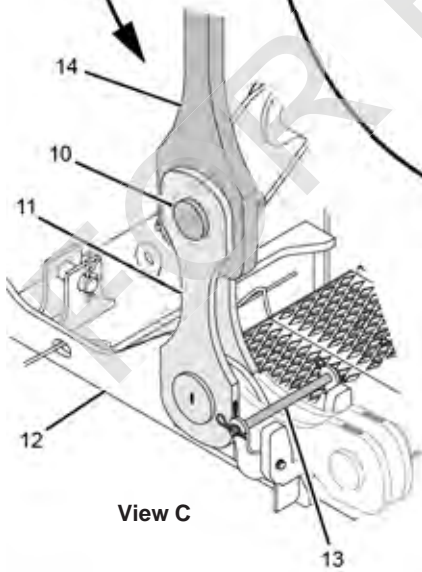

View C



View B

M104061B

Figure 4-52

See [Figure 4-52](#) for the following procedure.

7. Just prior to engagement between the mast stops (8, View B) and the mast stop lugs (9), stop lowering the fixed mast and confirm alignment.
8. Continue to lower the fixed mast. Stop lowering when the fixed mast stops (8, View B) come to rest in the mast stop lugs (9) on the rotating bed.
9. Continue to slowly haul in mast hoist wire rope and pay out boom hoist wire rope so the counterweight straps can be connected to the counterweight links.
10. Connect the counterweight straps to the counterweight links, as follows (see View C):
 - a. Remove the pins (10) from the counterweight links (11) on the VPC-MAX beam (12).
 - b. Remove the pins (13) and rotate the counterweight links (11) to vertical.
 - c. Install pins (10) to connect the counterweight links (11) to the counterweight straps (14). Repeat [step 8](#) as necessary to align the holes.
 - d. Reinstall the pins (13) in the strap brackets on the VPC-MAX beam (12).
11. Remove all hand-held taglines.

FOR REFERENCE ONLY

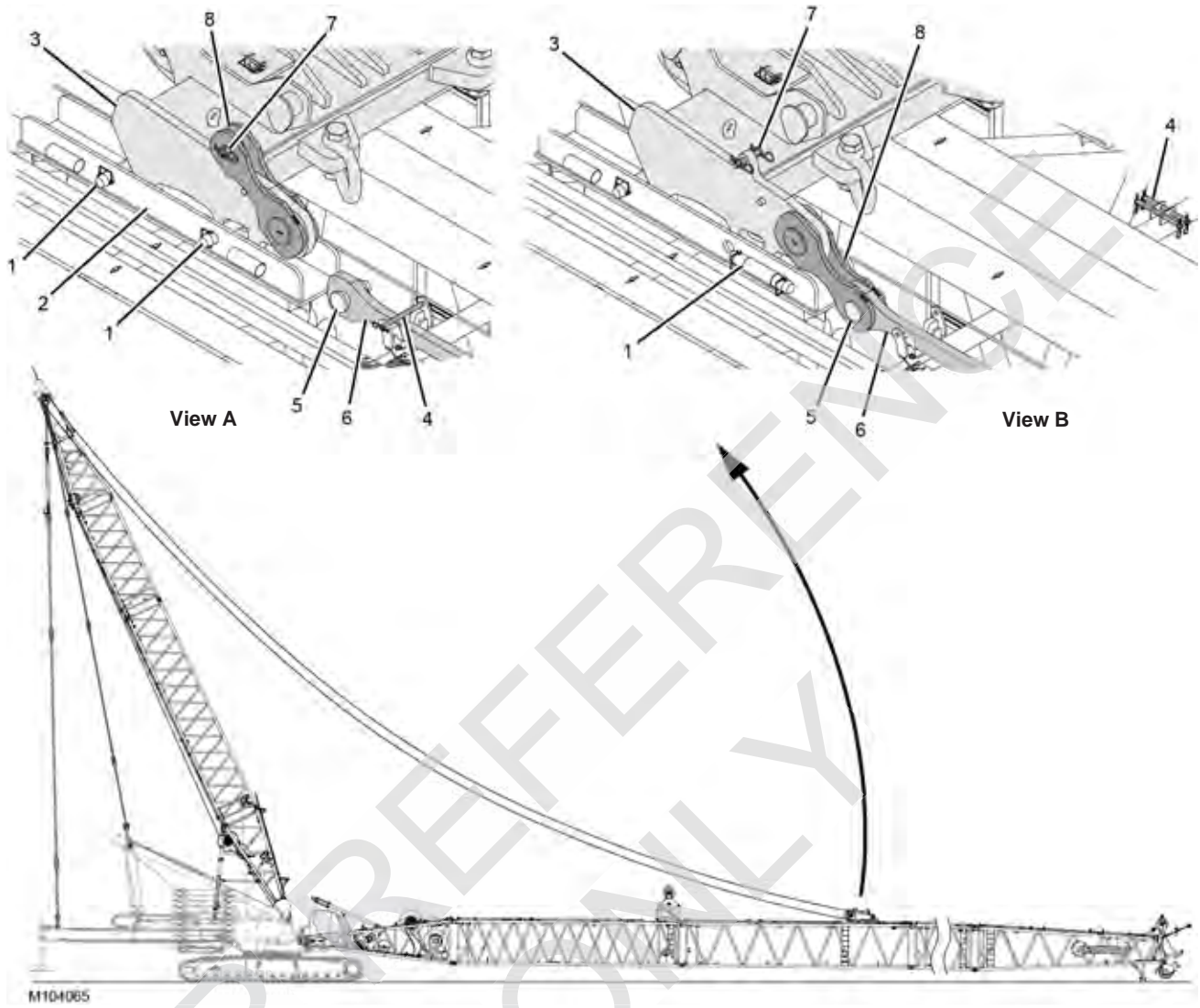

Boom Assembled in Proper Sequence According to the Boom Rigging Drawing

Item	Description
1	Stop Pin with Safety Pins (4)
2	Equalizer Rails (both sides of mast)
3	Boom Hoist Equalizer
4	Pins with Hair-Pin Cotters (2)
5	Pin with Collar, Retaining Pin, and Cotter Pins (2)
6	Boom Strap (2)
7	Pin with Hair-Pin Cotters (2)
8	Equalizer Links (4)

Figure 4-53

Install Boom

1. Move the boom hoist equalizer to side so it is clear of boom assembly area. Lift the boom hoist equalizer with the assist crane as shown in View A, [Figure 4-51 on page 4-86](#).

Take every precaution to protect wire rope from damage.

Do not allow wire rope to jump off sheaves (in fixed mast and in boom hoist equalizer) or otherwise become fouled.

2. Install boom. Make sure all of the steps are performed under the topic Boom #500 Assembly in Section 4 of the Crane Operator Manual.

Install Boom Hoist Equalizer on Equalizer Rails

1. Attach slings from the assist crane to the boom hoist equalizer as shown in View A, [Figure 4-51 on page 4-86](#).

See [Figure 4-53](#) for the remaining steps.

2. Make sure the stop pins (1, View A) are installed in the rear holes in the equalizer rails (2).
3. Remove the stop pins (1, View A) from the front holes in the equalizer rails (2).
4. Lift the boom hoist equalizer (3, View A) into position on the equalizer rails (2).

Haul in or pay out wire rope from Drum 5 as needed.

5. Pin the boom hoist equalizer to the front holes in the equalizer rails with stop pins (1, View A). **Stop pins must be installed to prevent boom hoist equalizer from accidentally sliding back on rails while connecting equalizer links.**

6. Disconnect the lifting slings.
7. Slacken the boom hoist wire rope.

Connect Equalizer Links to Boom Straps

See [Figure 4-49](#) for the following procedure.

1. Remove the pins (4, View A) and store them (View B).
2. Remove the pins (5, View B) from the boom straps (6).
3. Remove the pins (7, View A) and rotate the equalizer links (8) forward.
4. Pin the equalizer links (8, View B) to the boom straps (6) with pins (5).
5. Reinstall the pins (7, View B) in the boom hoist equalizer holes.

Install Counterweight Boxes

- See the Install Counterweight Boxes topic in Section 4 of the Crane Operator Manual for detailed instructions.
- Make sure the counterweight tray is at the minimum position as instructed on [page 4-49](#) of this section.

Adjust Fixed Mast and Beam Position

Adjust the fixed mast and beam position as instructed on [page 4-85](#).

Raise Boom

1. Enter the desired boom or jib configuration in the RCL/RCI display.
2. The boom can now be raised:
 - Perform "[Pre-Raising Checks](#)" on [page 4-92](#)
 - See "[Boom Raising Procedure](#)" on [page 4-93](#)

Item	Description
1	Position Indicator Light
2	Wind Speed Indicator
3	Limit Switch (lower and upper boom point)
4	Chain
5	Weight with 2-Chain Attachments
6	Lift Plate
7	Hook-and-Weight Ball
8	Weight with 1-Chain Attachment
9	Lift Block
10	Load Block
11	Shackle

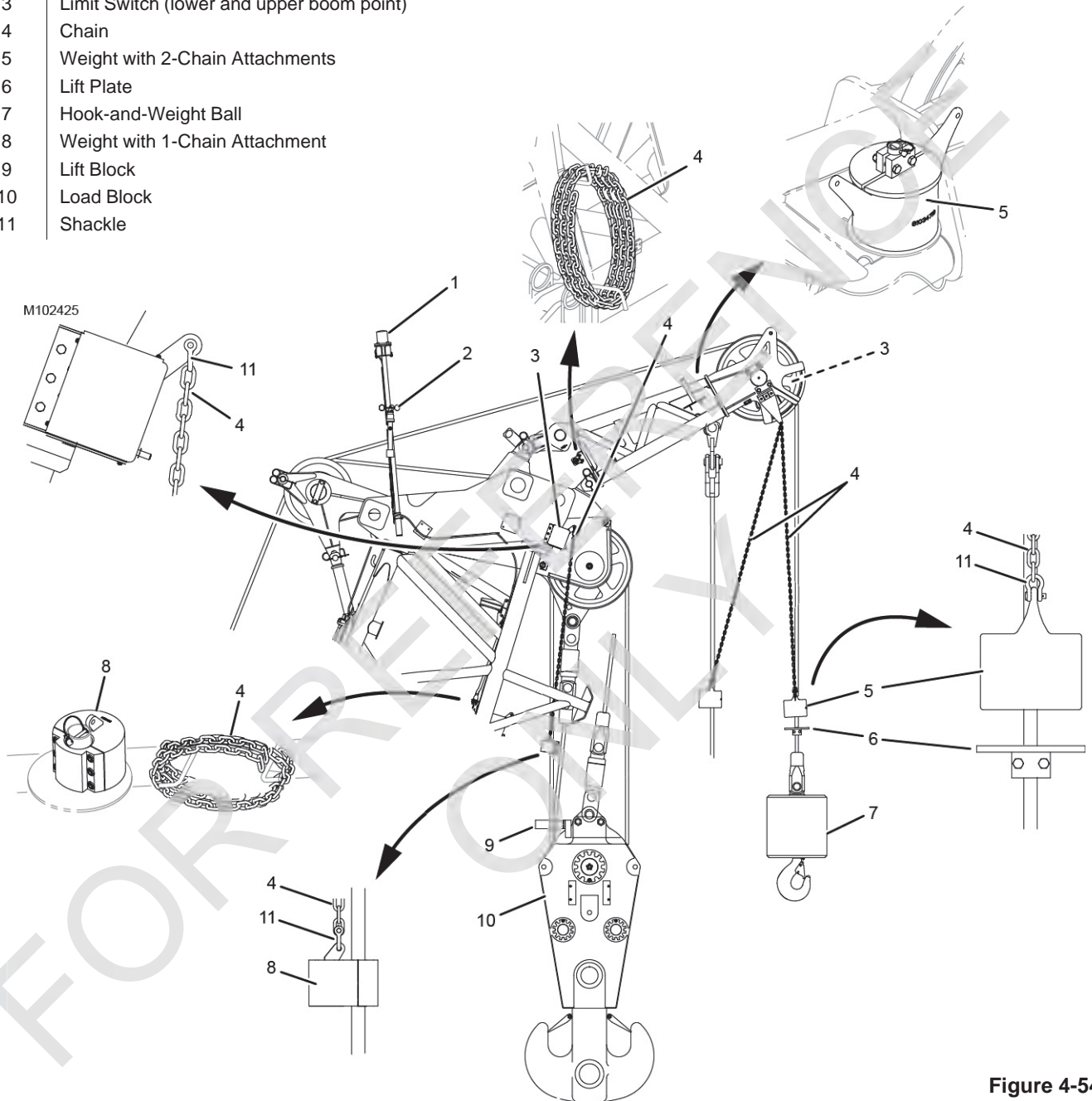

Figure 4-54

RAISING BOOM

Pre-Raising Checks

NOTE: Refer to the MLC300 Luffing Jib Operator Manual for the pre-raising checks and raising procedure when equipped with a luffing jib.

Perform the following checks before raising the boom and fixed jib:

- Maintenance and lubrication checks have been performed according to Maintenance Checklist and Lubrication Guide.
- Crane is on a firm, level, uniformly supporting surface.

- ❑ Desired counterweight (Series 1, 2, or 3) is installed.
- ❑ Crawlers are blocked if required per capacity chart in use.
- ❑ Boom and jib inserts are installed in proper sequence per boom and jib assembly drawings.
- ❑ Intermediate suspension insert is installed in proper position, if required.
- ❑ Intermediate suspension pendants are secured in proper operating position.
- ❑ All straps are unpinned from strap brackets unless they are allowed to remain in the shipping position during operation.
- ❑ All straps are properly pinned together. Cotter pins are installed and spread.
- ❑ Boom hoist equalizer straps are properly connected to boom straps.
- ❑ Boom hoist equalizer is unpinned from rails on insert.
- ❑ Boom hoist wire rope is spooled tightly onto boom hoist and engaged with the proper sheaves.
- ❑ Load lines are spooled tightly onto drums and engaged with proper sheaves.
- ❑ Load lines are securely anchored at boom and jib points or at load block and weight ball.
- ❑ All tools and other items are removed from boom and jib.
- ❑ Electrical cables from crane control system are connected to cable reel in boom butt.
- ❑ Electrical cables in boom and jib are connected to proper receptacles.
- ❑ Block-up limit control ([Figure 4-54](#)) is properly installed, operational, and adjusted.
- ❑ Position indicator light ([Figure 4-54](#)) is properly installed and operational.
- ❑ Wind speed indicator ([Figure 4-54](#)) is properly installed and operational.
- ❑ RCL/RCI is properly configured and operational.
- ❑ Proper capacity chart is selected in configuration screen of RCL/RCI display.
- ❑ Operator has read and is thoroughly familiar with selected capacity chart. Be sure to comply with boom raising limitations given in capacity chart.
- ❑ Wind is within allowable limits for operation given in Wind Conditions Chart at the end of Section 3.

Boom Raising Procedure

1. Verify that the pre-raising checks have been performed.

2. Refer to the capacity chart in use for boom raising limitations.



WARNING

Falling Boom/Tipping Hazard!

Before raising the boom:

- Determine the proper counterweight position from the capacity chart that will allow raising the boom length in use.
- Select the required counterweight position in the RCL/RCI Display when the boom is within the operating range of the capacity chart.
- Block under the crawlers if required.

3. SLOWLY start to boom up:
 - a. Have an assistant watch the boom straps as the boom rises.

Signal the operator to STOP raising the boom if the straps get caught on the inserts. **Correct the problem before continuing.**

- b. If equipped with intermediate suspension, have an assistant watch the intermediate suspension pendants as the boom rises:

Signal the operator to STOP raising the boom if the pendants get caught on the insert. **Correct the problem before continuing.**

4. SLOWLY continue to boom up.

5. If equipped with an upper boom point, stop when the bottom holes in the upper boom point are aligned with the holes in the boom top. Install the connecting pins. See Section 4 of Crane Operator Manual.

6. Continue to raise the boom until the lower and upper boom points are at a convenient height for installing the load block(s) and hook-or-weight ball.

7. Install the load block(s) and hook-or-weight ball at the lower and upper boom points. See [Wire Rope Installation on page 4-163](#).

8. Install the block-up limit components at the boom points.

9. If equipped with a jib, continue to raise the boom until the jib point is at a convenient height to install the load block or the hook-or-weight ball.

- a. Signal the operator to STOP raising the boom if the jib pendants get caught on the inserts. **Correct the problem before continuing.**

- b. Make sure the jib stop pins are properly installed. See the #148 Fixed Jib Assembly and Disassembly Guide at the end of this section.

- 10. Install the load block or hook-or-weight ball at the jib point.
- 11. Install the block-up limit components at the jib point. See [Wire Rope Installation on page 4-163](#)
- 12. Continue to boom up until the boom is at an angle that safely allows the load block(s) and/or hook-and-weight balls to be lifted.
- 13. Once the boom is raised:
 - a. Check all crane functions for proper operation.
 - b. Check all safety devices for proper operation (see Section 3 of the MLC300 Operator Manual).
 - c. Check that the boom stop is adjusted for the proper maximum boom angle.
 - d. Check that the RCL/RCI is properly calibrated.

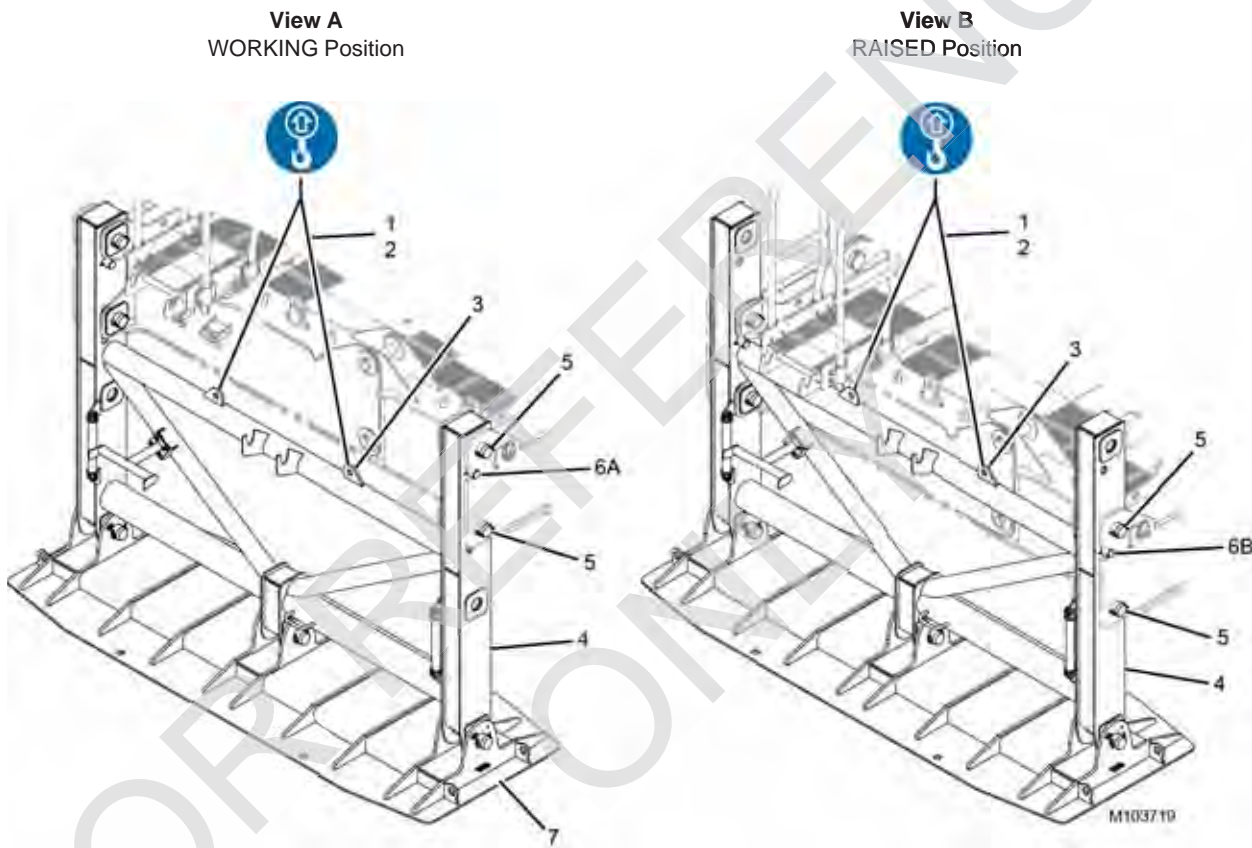

Item	Description
1	Shackle (2): 20,5 t (23 USt)
2	Lifting Sling (2): 2,8m (9 ft) Long
3	Lifting Lug (2)
4	Auxiliary Frame Assembly
5	Pin with Retaining Pins and Cotter Pins (4)
6	Alignment Pin (2)
7	Pad Area = 4,43 m ² (47.68 ft)

Figure 4-55

AUXILIARY FRAME OPERATING POSITIONS



WARNING

Structural Damage Hazard!

A sudden release of load and/or dynamic loading (due to swinging, hoisting, or lowering and adverse weather conditions to include wind) may cause structural damage due to shock loading and unintended motion of the crane.

The auxiliary frame assembly is provided to limit unintended motion of the VPC-MAX beam and counterweights during a sudden release of load and/or dynamic loading (due to swinging, hoisting, or lowering and adverse weather conditions to include wind).

The auxiliary frame assembly in no way substitutes for, or lessens, the requirement that the crane must be operated properly and safely, and that it must be inspected, serviced, and maintained regularly to minimize the potential for a sudden release of load and/or dynamic loading (due to swinging, hoisting, or lowering and adverse weather conditions to include wind).

The auxiliary frame assembly has two operating positions:

WORKING Position (View A):

This is the recommended operating position.

RAISED Position (View B):

This position can be used if additional clearance is required for swinging over job site obstacles.

Lower the auxiliary frame assembly after the obstacle is cleared. Continued operation with the auxiliary frame assembly raised is not recommended.

To change the operating position, proceed as follows:

NOTE The auxiliary frame assembly weighs approximately 1 600 kg (3,527 lb).

1. If installed, remove the ladder from the rear of the VPC-MAX beam. Reverse the installation steps under the topic [Install VPC-MAX Beam Ladder on page 4-47](#).
2. Proceed as follows to move the auxiliary frame assembly to the **RAISED position**:

- a. Attach the shackles (1, View A) and the lifting slings (2) to the lifting lugs (3) on the auxiliary frame assembly (4) and to the hook of an assist crane.
- b. Hoist just enough to loosen the pins (5, View A) and remove the pins.
- c. Lift the auxiliary frame assembly away from the VPC-MAX beam.
- d. Move the alignment pins (6, View A) from the top holes (A, View A) in the auxiliary frame assembly to the bottom holes (B, View B) in the auxiliary frame assembly.
- e. Lift the auxiliary frame assembly (1) into position at the end of the VPC-MAX beam so the alignment pins (6, View B) engage the notches in the beam.
- f. Install the pins (5, View B) to connect the auxiliary frame assembly (4) to the VPC-MAX beam.
- g. Disconnect the shackles and lifting slings from the auxiliary frame assembly.

3. Proceed as follows to move the auxiliary frame assembly to the **WORKING position**:

- a. Attach the shackles (1, View B) and the lifting slings (2) to the lifting lugs (3) on the auxiliary frame assembly (4) and to the hook of an assist crane.
- b. Hoist just enough to loosen the pins (5, View B) and remove the pins.
- c. Lift the auxiliary frame assembly away from the VPC-MAX beam.
- d. Move the alignment pins (6, View B) from the bottom holes (B, View B) in the auxiliary frame assembly to the top holes (A, View A) in the auxiliary frame assembly.
- e. Lift the auxiliary frame assembly (1) into position at the end of the VPC-MAX beam so the alignment pins (6, View A) engage the notches in the beam.
- f. Install the pins (5, View A) to connect the auxiliary frame assembly (4) to the VPC-MAX beam.
- g. Disconnect the shackles and lifting slings from the auxiliary frame assembly.

4. Install the ladder on the rear of the VPC-MAX beam. See [Install VPC-MAX Beam Ladder on page 4-47](#).

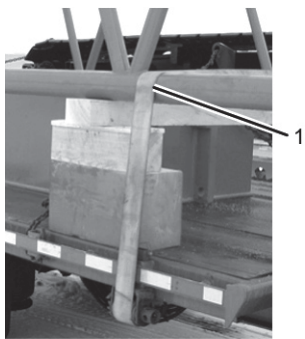

M103130

View A

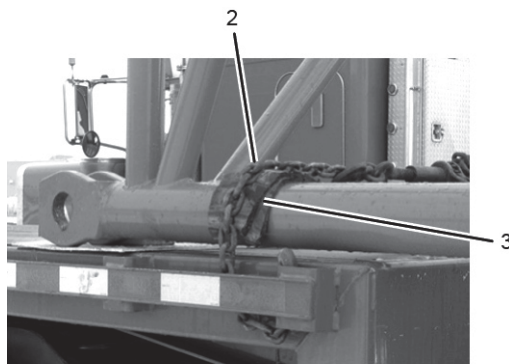

M103131

View B

Item	Description
1	Synthetic Tie-Down Wrapped Over Boom Chord
2	Chain Tie-Down Wrapped Over Boom Chord
3	Protective Covering (section of rubber tire)

Figure 4-56

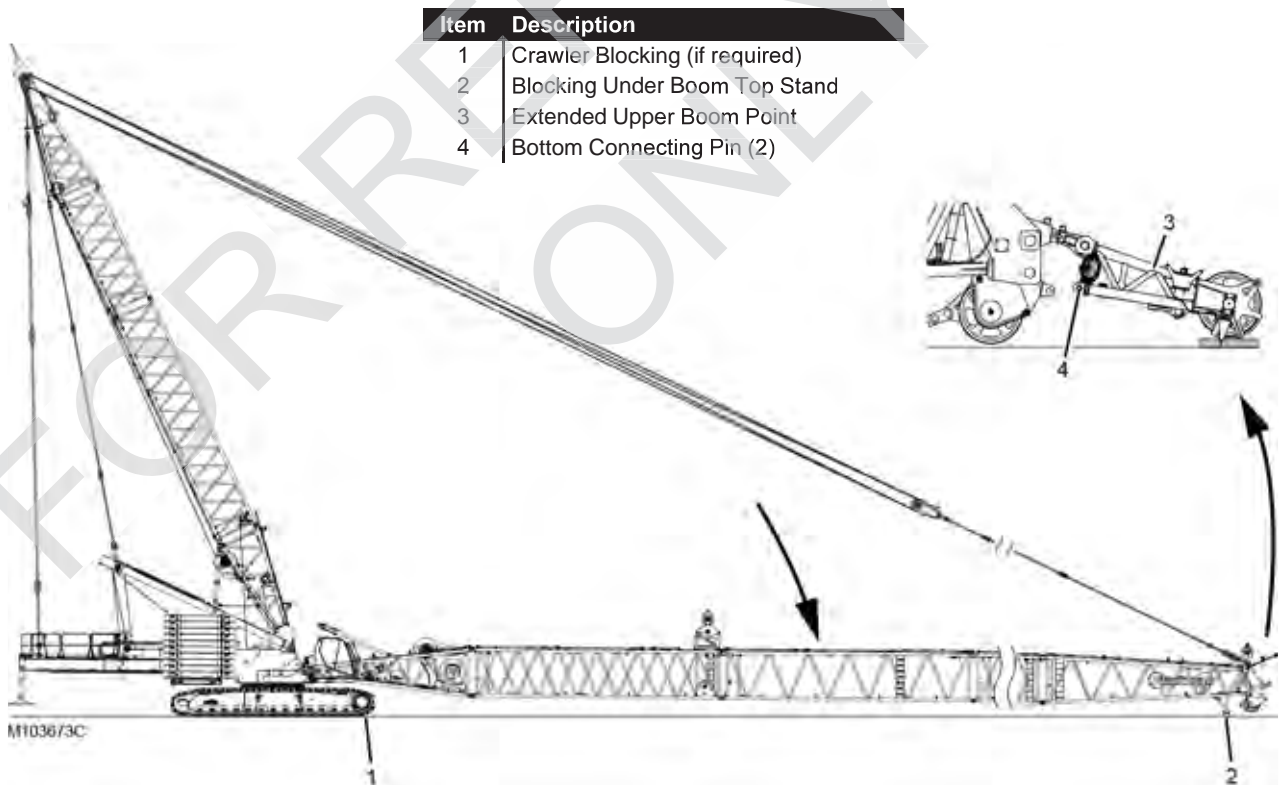

M103673C

Figure 4-57

SHIPPING CRANE COMPONENTS

It is the owner/user's responsibility to ensure the following:

- All trailer loads comply with local, state, and federal transportation requirements.
- All crane components are properly blocked and secured so they cannot shift or fall off trailers.
- To avoid damage to components:

Use synthetic tie-downs to secure components as shown in [Figure 4-56](#), View A.

If chain tie-downs are used, install protective covering (such as sections of rubber tire) between the chain and the component being secured as shown in [Figure 4-56](#), View B.

When securing boom sections, wrap the tie-downs over the chords — never over the lacings. Keep the tie-downs as close to the blocking as possible (View A) to prevent bending the chords.

LOWERING BOOM

See [Figure 4-57](#) for the following procedure.

1. Refer to the capacity chart in use for boom lowering limitations.



WARNING

Falling Boom/Tipping Hazard!

Before lowering the boom:

- Determine the proper counterweight position from the capacity chart that will allow lowering the boom length in use.
- Select the required counterweight position in the RCL/RCI Display when the boom is within the operating range of the capacity chart.
- Block under the crawlers if required.

2. Travel the ends of the crawlers onto blocking (1) if required per the capacity chart. See Crawler Blocking in the Capacity Chart Information Manual.

3. If necessary per the capacity chart, swing the boom to either side of center and lower the load blocks and/or the hook-and-weight balls to the ground. Take every precaution to prevent damage to the load lines.
4. Swing the boom to the required lowering position:
 - Over the end of the blocked crawlers
 - Over the end or side of the crawlers
5. Slowly lower the boom while performing the following steps:
 - a. If equipped with a luffing jib, refer to the Luffing Jib Operator Manual for lowering instructions.
 - b. If equipped with a fixed jib, disengage the jib stops before the jib point contacts the ground. Refer to the #148 Fixed Jib Assembly and Disassembly Guide at the end of this section for instructions.
 - c. If equipped with an upper boom point (3, [Figure 4-57](#)), remove the bottom connecting pins (4) when the upper boom point just contacts the ground.
6. Pay out the load lines as the boom lowers.
7. Install blocking (2), as desired, under the boom top stand.
8. Stop lowering the boom when the boom straps just start to lower.
9. Once the boom is on blocking, enter the Fixed Mast Configuration in the RCL/RCI display. See [Configure Fixed Mast in RCL/RCI Display on page 4-69](#).
10. Check the following:
 - The counterweight tray is fully retracted to the minimum working position of 0.96 m as indicated in the VPC-MAX calibration screen in the main display. Drive the tray in with the remote control if necessary.
 - The VPC-MAX beam is resting on the hooks (View C, [Figure 4-18 on page 4-28](#)). Slacken the boom rigging if necessary.

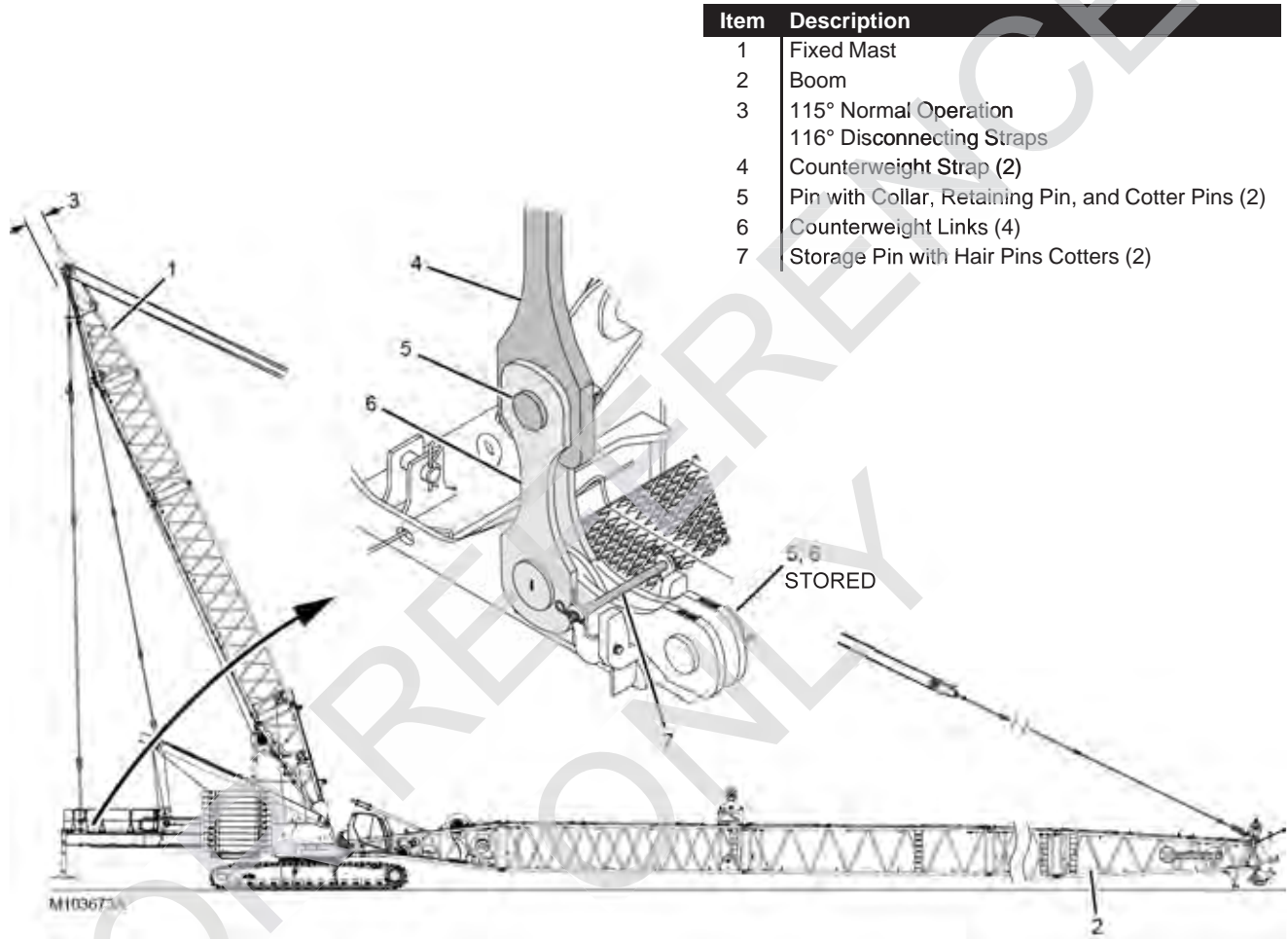

Figure 4-58

FIXED MAST LOWERING METHODS

There are two fixed mast lowering methods:

Preferred Method using Boom Holdback

For this method, all of the procedures and steps given on [page 4-99](#) through [page 4-109](#) must be performed. In general for this method:

- The fixed mast is lowered to the VPC-MAX disassembly position (boom is used as holdback).
- The boom hoist equalizer is disconnected from the boom straps.
- An assist crane is used to disassemble and remove the boom sections.
- The fixed mast is used as a boom to remove and disassemble the partial boom.
- The crane counterweight is removed, AFTER the fixed mast is used as a boom and the fixed mast is lowered to the disassembly position.

Alternate Method using Anchor Holdback

For this method, all of the procedures and steps given on [page 4-111](#) through [page 4-113](#) must be performed. In general for this method:

- The crane counterweight is removed BEFORE the boom is removed and the fixed mast is lowered to the disassembly position.
- The boom hoist equalizer is disconnected from the boom straps.
- The boom hoist equalizer is placed on the ground alongside the boom.
- An assist crane is used to disassemble and remove the boom.
- The fixed mast is anchored to a holdback weight.
- The fixed mast is lowered to the disassembly position.

LOWERING FIXED MAST — PREFERRED METHOD WITH BOOM HOLDBACK

Disconnect Counterweight Straps

See [Figure 4-58](#) for the following procedure.

1. Using the Drum 4 and 5 control handles, slowly haul in the mast hoist wire rope and pay out the boom hoist wire rope so the counterweight straps are slack.

This step will pull the fixed mast back to approximately 116° as indicated in the fixed mast working screen in the RCL/RCI display.

2. Disconnect the counterweight straps from the counterweight links on one side of the mast at a time:

- a. Attach a hand-held tagline approximately 9 m (30 ft) long to the counterweight strap (4).

The tagline will be used to guide the strap rearward by assembly personnel when the pin is removed in [step b](#).

- b. Remove the pin (5) connecting the counterweight links (6) to the counterweight strap (4).

Repeat [step 1](#) as necessary to loosen the pins.

- c. Pay out the hand-held tagline until the counterweight strap is hanging vertical.

- d. Remove storage pin (7) from the storage bracket.

- e. Rotate the counterweight links (6) forward onto the storage bracket.

- f. Install storage pin (7).

- g. Reinstall the pin (5) in the counterweight links (6).

- h. Repeat the steps on the other side of the fixed mast.

- i. Leave the hand-held taglines attached to the counterweight straps.

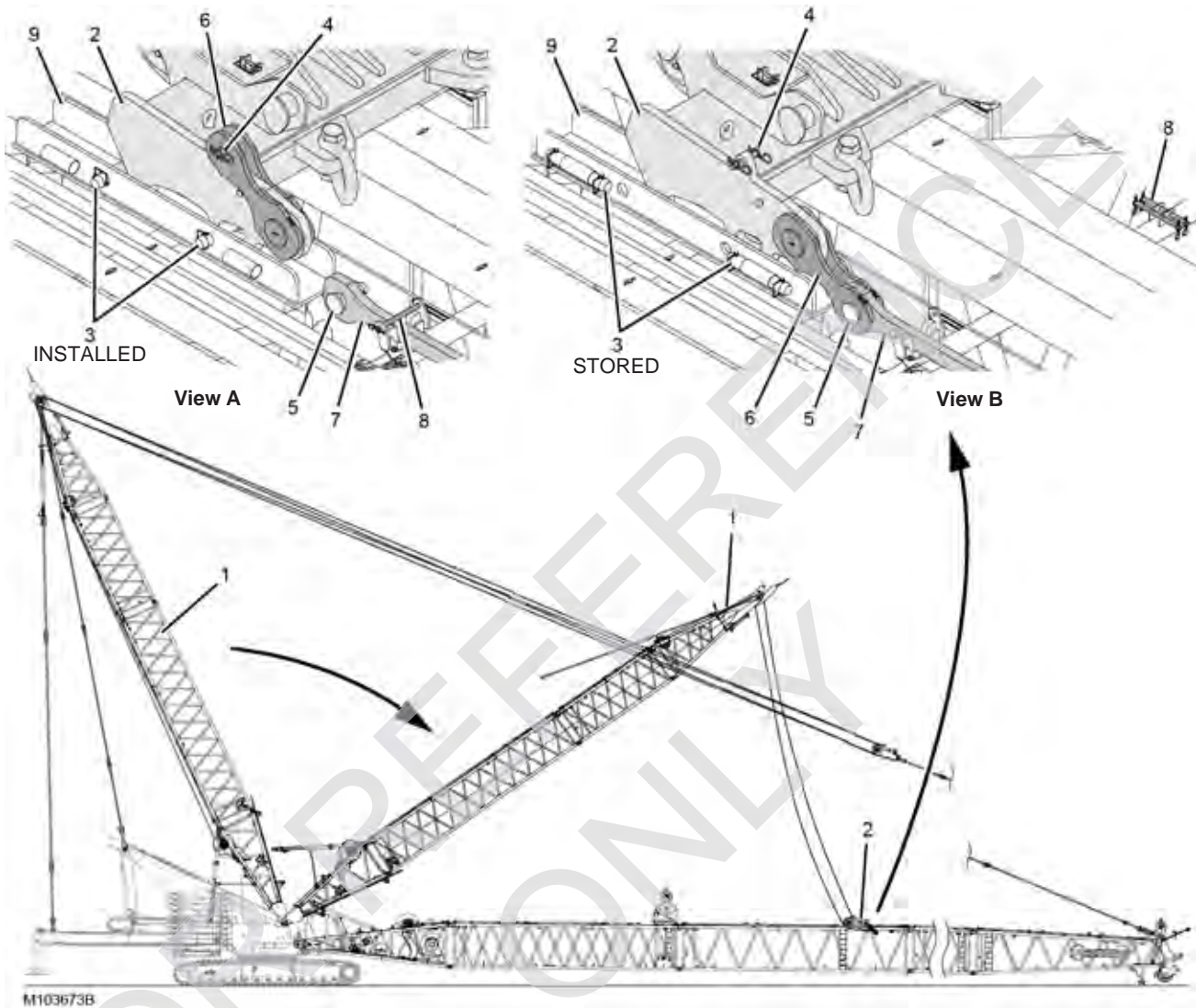

Item	Description
1	Fixed Mast
2	Boom Hoist Equalizer
3	Stop Pin with Safety Pin (4)
4	Pin with Hair-Pin Cotters (2)
5	Pin with Collar, Retaining Pin, and Cotter Pins (2)
6	Equalizer Link (4)
7	Boom Strap (2)
8	Pin with Hair-Pin Cotters (2)
9	Equalizer Rails (both sides of insert)

Figure 4-59

Lower Fixed Mast to Disassembly Position

See [Figure 4-59](#) for the following procedure.

- Slowly boom up (haul in boom hoist wire rope) while paying out the mast hoist wire rope to raise the fixed mast (1) toward vertical.
 - The mast hoist wire rope must remain slack until the fixed mast nears vertical.**
 - Use care not to allow the straps to bounce up and down against the boom sections.**

NOTE As the fixed mast rises, the crane control system monitors mast tension (right side only) and automatically slows down either Drum 4 or Drum 5 to maintain the constant target tension specified on [page 4-71](#).

The mast tension can be monitored in the Crane Status Bar of the Main Display (see View E, [Figure 4-44 on page 4-72](#)).

- Guide the counterweight straps around the live mast with the hand-held taglines and into storage brackets on fixed mast.
- As the fixed Mast nears vertical, tighten the mast hoist wire rope as required so the fixed mast moves smoothly forward past vertical.
- Continue to slowly pay out the mast hoist wire rope and haul in the boom hoist wire rope to lower the fixed mast toward the boom.
- If equipped with intermediate suspension, have an assistant watch the intermediate suspension pendants as the mast lowers. The pendants must fold into the insert.
Signal the operator to STOP lowering the mast if the intermediate suspension pendants get caught on the insert. Correct the problem before continuing.
- Continue to slowly pay out the mast hoist wire rope and haul in the boom hoist wire rope so the equalizer (2) comes to rest on the equalizer rails (9) and the boom straps come to rest in the brackets on the top of the boom sections. Make sure the equalizer is on the forward side of the rear stop pins (3, View A).

CAUTION

Mast Damage!

Do not allow the fixed mast to contact Drum 1 in the boom butt. Damage to the fixed mast and/or drum could result.

- Stop lowering the fixed mast before it is at approximately 15° or damage can occur.
- Make sure the equalizer is on the forward side of the rear stop pins (3, View A).

- Remove the front stop pins (3, View B) from storage and install them to pin the equalizer (2) to the equalizer rails (9).

Disconnect Equalizer Links from Boom Straps

See [Figure 4-59](#) for the following procedure.

- Remove the pins (4, View B).
- Remove the pins (5, View B) and rotate the equalizer links (6) rearward.
- Pin the equalizer links (6, View A) to the boom hoist equalizer (2) with the pins (4).
- Reinstall the pins (5, View A) in the boom straps (7).
- Remove the pins (8, View B) from storage and install them over the boom straps (7, View A).



WARNING

Falling Mast/Tipping Hazard!

Prevent the mast from falling:

- Do not raise the fixed mast higher than 69° after the equalizer is disconnected from the boom.
- The mast could fall over backwards or the crane could tip if this precaution is ignored.

Prepare Boom for Removal

- Refer to the Crane Disassembly topic in the Crane Operator Manual and perform the following steps:
 - Remove and store the block-up limit components.
 - Store the load lines on the drums.
 - Remove and store the boom top camera, the position light, and wind speed indicator.
 - Disconnect and store the electric cables between the crane and the boom butt.
Be sure to connect the CAN D terminator ([Figure 4-9 on page 4-12](#)) to the CAN electric cable at the front of the rotating bed. The engine may not start and faults may be activated if this step is not performed.
 - Disconnect and store the hydraulic lines between the crane and the boom butt.
 - Disconnect and store the electric cables in the boom top.
 - Store the electric cables on the cable reels in the boom butt.

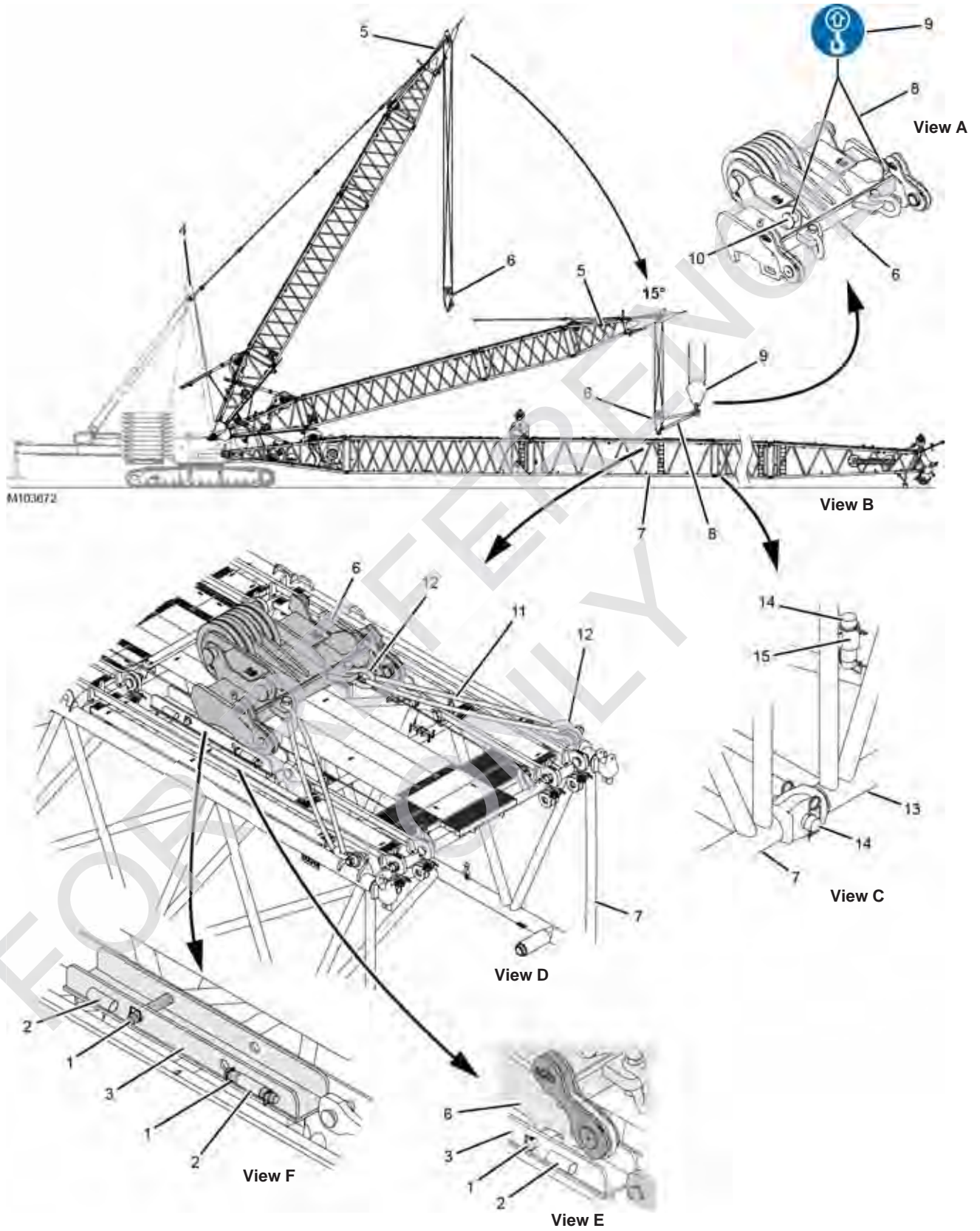

Figure 4-60

Legend for [Figure 4-48](#)

Item	Description
1	Stop Pin with Safety Pins (4)
2	Storage Tube (4)
3	Rails (2 sets)
4	Live Mast
5	Fixed Mast
6	Boom Hoist Equalizer
7	12 m Insert (with equalizer rails)
8	Synthetic Lifting Sling (2): 2,8 m (9 ft)
9	Assist Crane Hook
10	Lifting Lug (front 2)
11	Synthetic Lifting Sling (2): 1,87 m (6.1 ft)
12	Shackle (4)
13	Adjacent Insert
14	Pin with Safety Pin (2)
15	Storage Tube (2)

Disconnect Boom Sections

See [Figure 4-60](#) for the following procedure.

1. Disconnect and store the boom straps between the 12 m insert (7) and the adjacent boom insert.
2. Connect two synthetic lifting slings (11, View D) between the shackles (12) on the boom hoist equalizer (6) and the 12 m insert (7).
3. Remove the front stop pins (1, View E) from the front holes in the boom hoist equalizer rails (3) and install the pins in the front storage tubes (2, View F).
4. Position the fixed mast at 28°.
5. Slowly haul in the boom hoist wire rope until the boom hoist equalizer (6, View D) is out of the rails (3) and the synthetic lifting slings (11) are tight.

CAUTION

Boom or Mast Damage!

Do not attempt to lift the entire boom during the following step. Damage to the fixed mast and/or boom could result.

Do not exceed a mast strap tension of 155 t (342,000 lb) — 77,6 t (171,000 lb) per strap. Mast strap tension can be monitored in the Crane Status Bar of the Main Display (View E, [Figure 4-44 on page 4-72](#)).



WARNING

Crushing Injury Hazard!

Prevent serious crushing injury:

- Do not stand inside the boom sections while installing the tapered connecting pins — **STAND OUTSIDE BOOM.**
6. Remove the pins (14, View C) from between the 12 m insert (7) and the adjacent insert (13).
 7. Store the pins (14, View C) in the storage tubes (15).
 8. Slowly pay out the boom hoist wire rope to lower the boom sections on blocking.

CAUTION

Mast Damage!

Do not allow the fixed mast to contact Drum 1 in the boom butt during the following steps. Damage to the fixed mast and/or drum could result.

9. Continue to pay out the boom hoist wire rope until the fixed mast (5, View B) is at approximately 15°, the boom hoist equalizer is resting on the rails (3, View D), and the synthetic lifting slings (11) are slack.
10. Disconnect the synthetic lifting slings (11, View D) from between the shackles (12) on the boom hoist equalizer (6) and the 12 m insert (7).
11. The shackles (12) can remain attached to the boom hoist equalizer (6) and the 12 m insert (7).
12. Connect two synthetic lifting slings (8, View A) to the hook of the assist crane (9) and to lifting lugs (10) on the boom hoist equalizer (6).
13. Slowly haul in the boom hoist wire rope and lift the boom hoist equalizer with the assist crane until the boom hoist equalizer is clear of the boom.
14. Raise the fixed mast, pay the boom hoist wire rope, and lower the equalizer with the assist crane until the equalizer is hanging vertical.
15. Disconnect the synthetic lifting slings (8, View A) from the boom hoist equalizer (6).
16. Remove the rear stop pins (1, View F) from the rear holes in the boom hoist equalizer rails (3) and install the pins in the rear storage tubes (2).

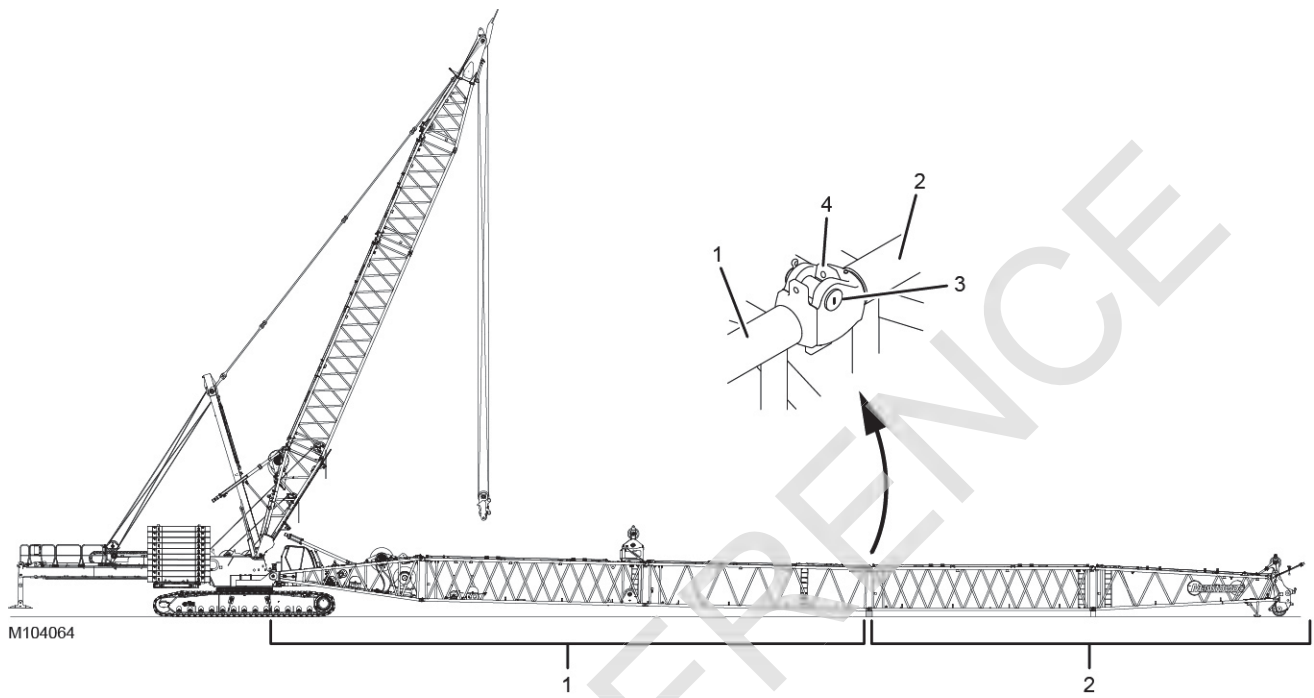

M104064

Assembled in Proper Sequence According to the Boom Rigging Drawing

Item	Description
1	Partial Boom
2	Remaining Boom Sections (inserts and top)
3	Fixed Horizontal Pin (2)
4	Hooked Connector (2)

Figure 4-61

Disconnect Boom Straps

Starting at the boom top disconnect and store the boom straps between all of the boom sections, to include the 1,69 m (5.5 ft) straps on the 12 m (39.4 ft) insert with boom hoist equalizer rails.

- Reverse the Connect Boom Straps topic in Section 4 of the Crane Operator Manual.

Disassemble Boom Sections

See [Figure 4-61](#) for the following procedure.

Using an assist crane, disassemble the boom sections (2) from the end of the partial boom (1).

- Reverse the Assemble Boom Inserts and Top topic in Section 4 of the Crane Operator Manual.
- The fixed mast can be used to disassemble the boom sections (2) once the partial boom (1) is removed.

FOR REFERENCE ONLY

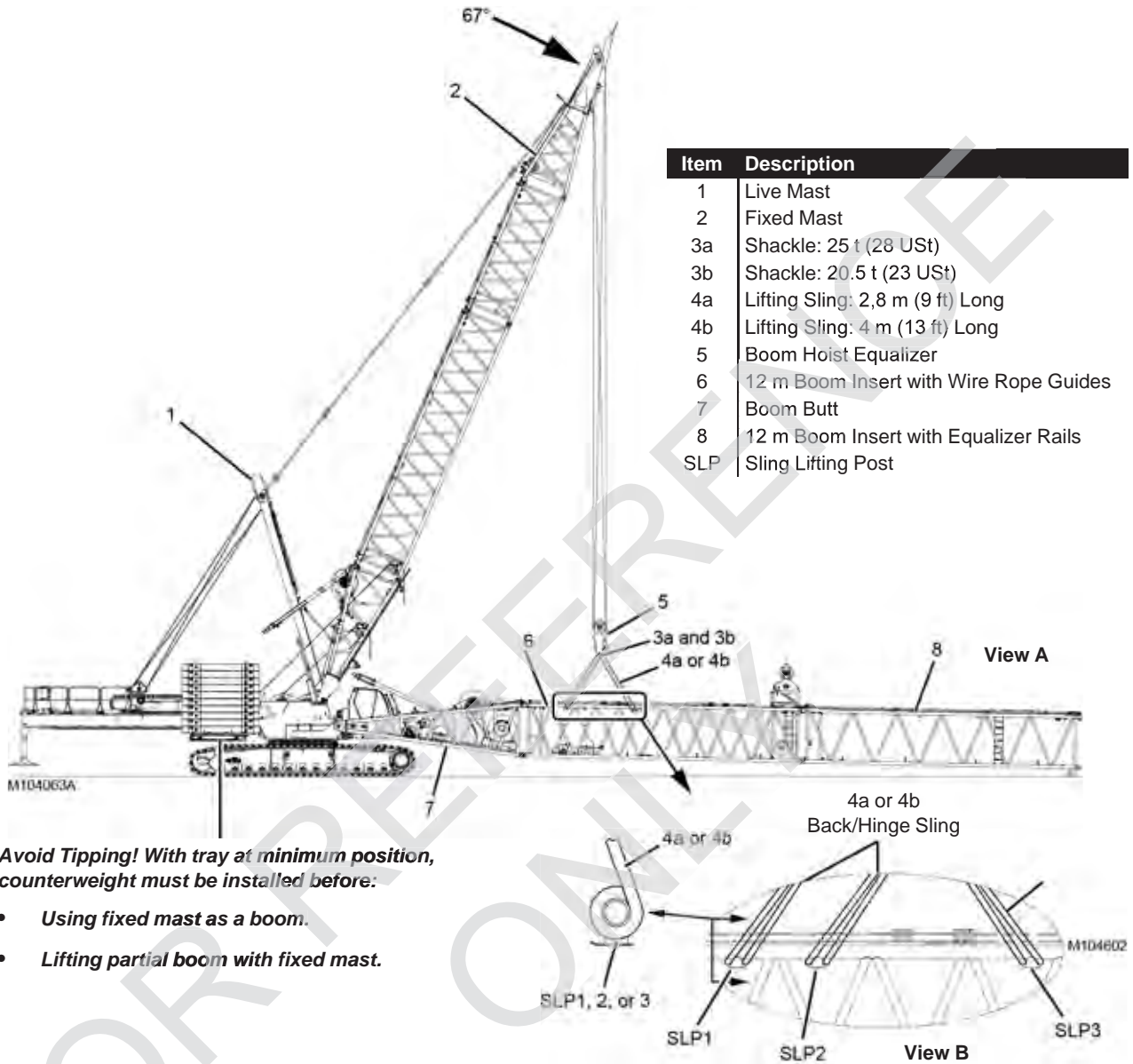

Partial Boom Lifting Table

Insert Configuration	Qty 4 Sling Item No.	Item 3a	Back/Hinge Sling					Front/Top Sling				
			SLP Item No.	Left		Right		SLP Item No.	Left		Right	
				Item 3b	Wrap on Chord	Item 3b	Wrap on Chord		Item 3b	Wrap on Chord	Item 3b	Wrap on Chord
with Luffing Jib Backstay Straps and with Drum 6	4a	2	1	0	0	0	0	3	1	0	0	0
	4b	2	1	0	0	0	0	3	1	0	0	0
without Luffing Jib Backstay Straps and with Drum 6	4a	2	1	1	1	1	1	3	1	0	0	0
	4b	2	1	0	0	0	0	3	2	0	1	0
without Luffing Jib Backstay Straps and without Drum 6	4a	2	2	0	0	0	0	3	0	0	0	0
	4b	2	2	0	0	0	0	3	0	0	0	0

Figure 4-62

Remove Partial Boom

See [Figure 4-62](#) for the following procedure.

WARNING Tipping Hazard!

Prevent the crane from tipping:

- The crane counterweight must be installed to handle the partial boom with the fixed mast.
- The crane could tip forward if this precaution is ignored.

1. Prepare the fixed mast for partial boom handling as shown in View A:
 - Lower the live mast (1, View A) so the fixed mast (2) is at approximately 67°.
 - To ensure the partial boom lifts level, attach the shackles (3a and 3b) and four lifting slings (4a or 4b) to the equalizer (5) and the appropriate posts

(SLP1, 2, or 3, View B) on the 12 m boom insert (6).
See the Partial Boom Lifting Table.

See View A, [Figure 4-44 on page 4-72](#) for the shackle attachment locations on the equalizer.

2. Attach hand-held taglines to the partial boom so the partial boom can be stabilized from swinging when the boom hinge pins are disconnected.
3. Haul in the boom hoist wire rope to lift the partial boom until it is horizontal.
4. Disconnect the boom butt from the crane as instructed in Section 4 of the MLC300 Crane Operator Manual.
5. Slowly lower the live mast and payout the boom hoist wire rope to lower the partial boom onto blocking (View C) 330 mm (13 in) high under the boom sections.
6. Disconnect the lifting slings from the 12 m insert (6).
7. Disconnect and store the hydraulic hoses for the boom hinge pins as instructed in Section 4 of the MLC300 Crane Operator Manual.

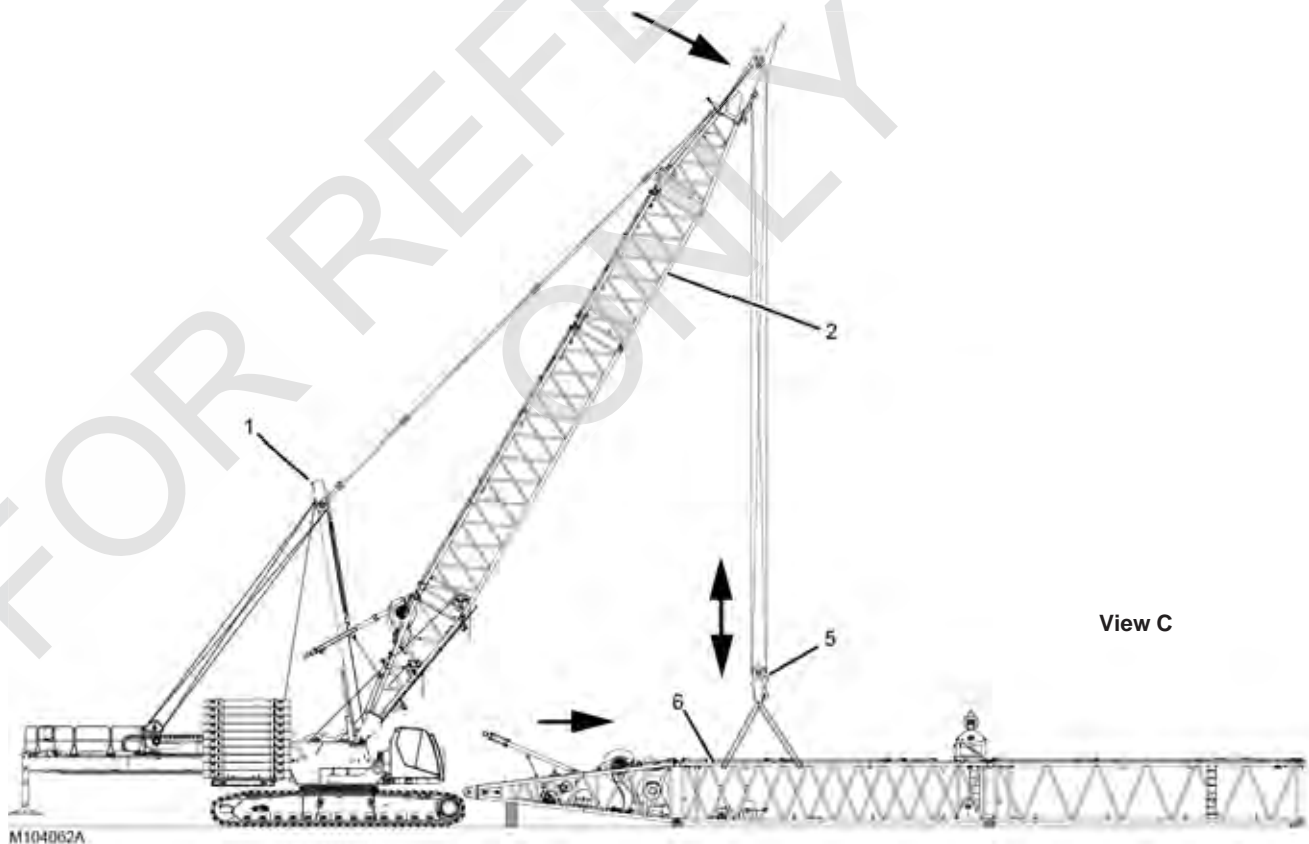

Figure 4-62 continued

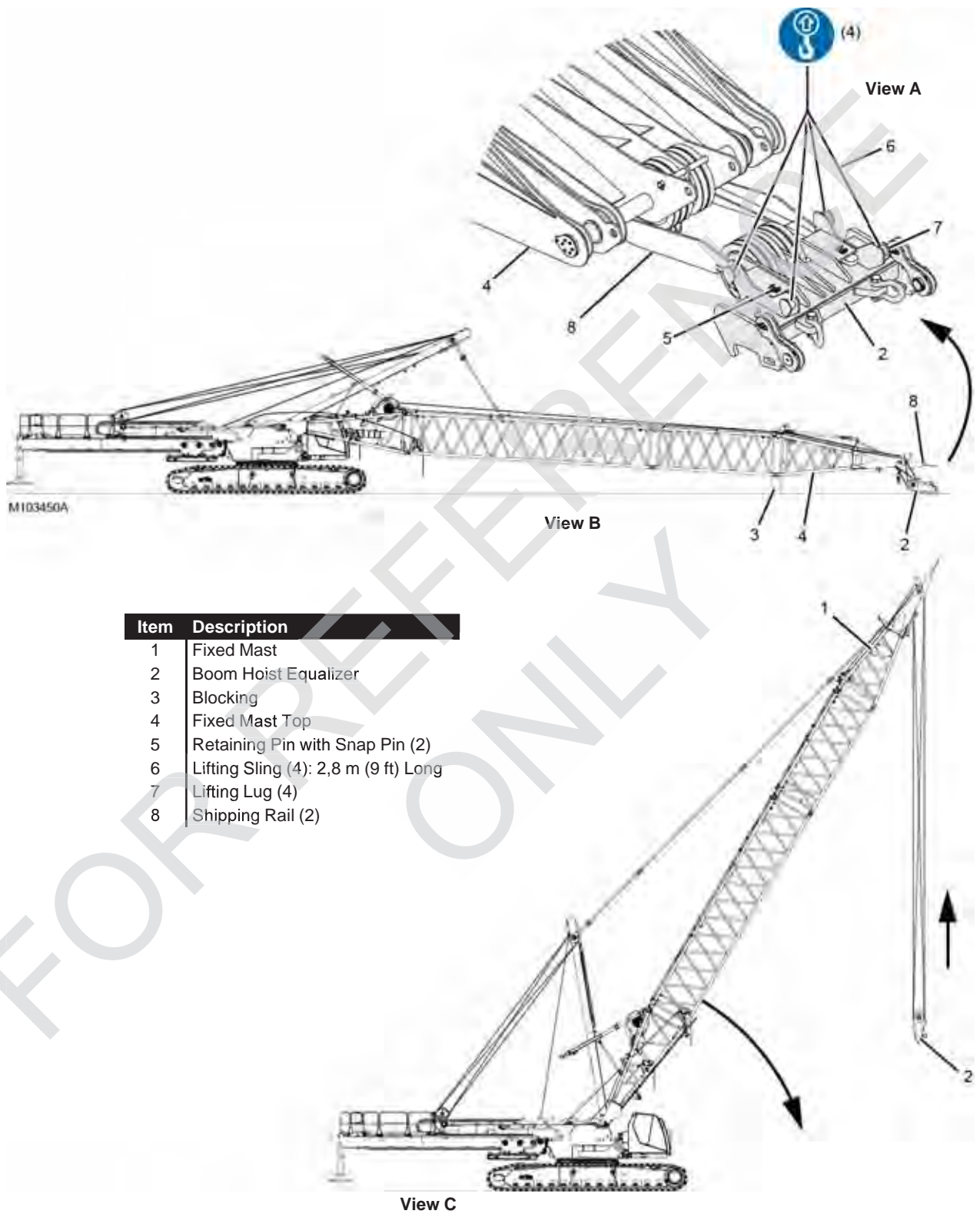

Figure 4-63

Disassemble Partial Boom

The partial boom can be disassembled with the fixed mast or with an assist crane.

To disassemble the partial boom, reverse the steps under "[Assemble Partial Boom](#)" on page 4-75.

Once the boom is disassembled, remove the shackles ([Figure 4-62](#)) and lifting slings from the boom hoist equalizer.

Remove Counterweight Boxes

- See the Remove Counterweight Boxes topic in Section 4 of the Crane Operator Manual for detailed instructions.
- Make sure the counterweight tray is at the minimum position as instructed on [page 4-49](#) of this section.

Lower Fixed Mast to Disassembly Position

See [Figure 4-63](#) for the following procedure.

1. Slowly mast down using the Drum 4 control handle to lower the fixed mast (1, View C).
2. Continue to mast down (View C) while raising the boom hoist equalizer (2) with the Drum 5 control handle.

3. Continue the lowering process to lower the fixed mast onto blocking (3, View B) that is a minimum of 610 mm (24 in) high. Do not lower the fixed mast to more than 4° below horizontal.
4. Allow the boom hoist equalizer (2, View A) to land on the ground below the mast top (4).

Connect Boom Hoist Equalizer to Mast Top

See [Figure 4-63](#), View A for the following procedure.

1. Remove the retaining pins (5) from the boom hoist equalizer (2).
2. Attach the lifting slings (6) to the lifting lugs (7) on the boom hoist equalizer (2) and to the hook of the assist crane.
3. Lift the boom hoist equalizer onto the shipping rails (8) on the end of the mast top (4) while hauling in the boom hoist wire rope onto Drum 5.
4. Install the retaining pins (5) to attach the boom hoist equalizer to the shipping rails (8).
5. Disconnect the lifting slings from the boom hoist equalizer.

CAUTION

Avoid Mast Damage

Do not lower the fixed mast to more than 4° below horizontal. Damage to the mast hinge or rotating bed can occur.

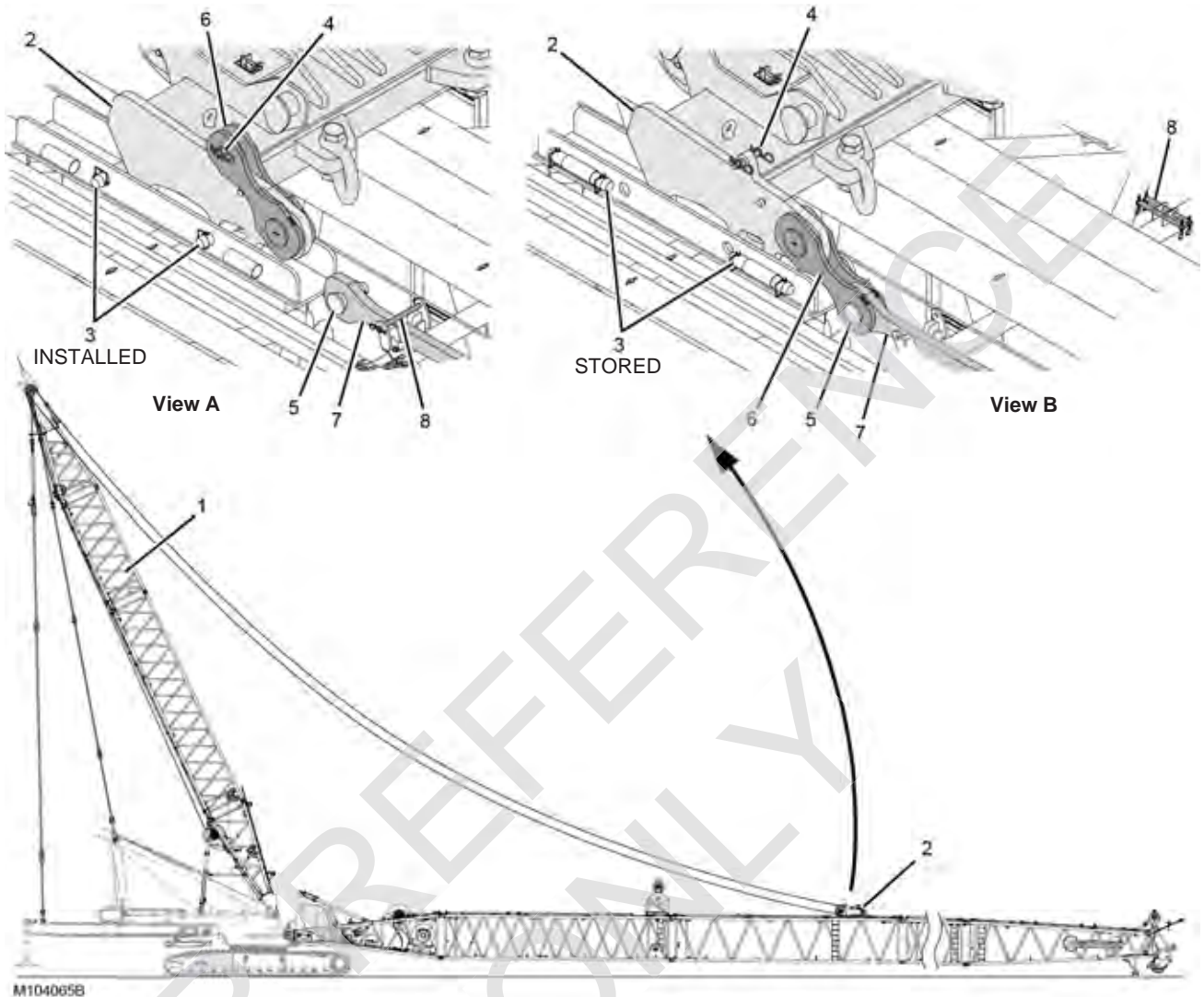

Boom Assembled in Proper Sequence According to the Boom Rigging Drawing

Item	Description
1	Fixed Mast
2	Boom Hoist Equalizer
3	Stop Pin with Safety Pin (4)
4	Pin with Hair-Pin Cotter (2)
5	Pin with Collar, Retaining Pin, and Cotter Pins (2)
6	Equalizer Link (4)
7	Boom Strap (2)
8	Pin with Hair-Pin Cotter (2)

Figure 4-64

LOWERING FIXED MAST — ALTERNATE METHOD WITH ANCHORED HOLDBACK

Remove Counterweight Boxes

The counterweight boxes must be removed before lowering the fixed mast with a anchored holdback.

- See the Remove Counterweight Boxes topic in Section 4 of the Crane Operator Manual for detailed instructions.
- Make sure the counterweight tray is at the minimum position as instructed on [page 4-49](#) of this section.



WARNING

Tipping Hazard!

Prevent the crane from tipping:

If the counterweight is installed, do not raise the fixed mast above 69° until boom is attached to the crane and the equalizer is attached to the boom straps.

- Disconnect Equalizer Links from Boom Straps

See [Figure 4-64](#) for the following procedure.

1. With the boom supported on blocking, slowly boom down until the boom hoist equalizer (2, View B) lands in the rails on the corresponding boom section.
2. Remove the stop pins (3, View B) from storage and install them as shown in (View A) to secure the equalizer to the rails.
3. Remove the pins (4, View B).
4. Remove the pins (5, View B) and rotate the equalizer links (6) rearward.
5. Pin the equalizer links (6, View A) to the boom hoist equalizer (2) with the pins (4).
6. Reinstall the pins (5, View A) in the boom straps (7).
7. Remove the pins (8, View B) from storage and install them over the boom straps (7, View A).

Remove Boom Hoist Equalizer from Equalizer Rails

1. Attach slings from the assist crane to the boom hoist equalizer as shown in View A, [Figure 4-65 on page 4-112](#).

See [Figure 4-64](#) for the remaining steps.

2. Make sure the stop pins (3, View A) are installed in the rear holes in the equalizer rails.
3. Remove the stop pins (3, View A) from the front holes in the equalizer rails and store the pins (View B).
4. Lift the boom hoist equalizer (2, View A) off the equalizer rails and place the equalizer on the ground along the desired side of the boom so the boom hoist equalizer is clear of the boom disassembly area.

Take every precaution to protect wire rope from damage.

Do not allow wire rope to jump off sheaves (in fixed mast and in boom hoist equalizer) or otherwise become fouled.

Remove Boom

Refer to the Crane Disassembly topic in the Crane Operator Manual and perform the following steps:

1. Remove and store the block-up limit components.
2. Store the load lines on the drums.
3. Remove and store the boom top camera, the position light, and wind speed indicator.
4. Disconnect and store the electric cables between the crane and the boom butt.

Be sure to connect the CAN D terminator ([Figure 4-9 on page 4-12](#)) to the CAN electric cable at the front of the rotating bed. The engine may not start and faults may be activated if this step is not performed.
5. Disconnect and store the hydraulic lines between the crane and the boom butt.
6. Disconnect and store the electric cables in the boom top.
7. Store the electric cables on the cable reels in the boom butt.
8. Starting at the boom top disconnect and store the boom straps between all of the boom sections, to include the 1,69 m (5.5 ft) straps on the 12 m (39.4 ft) insert with boom hoist equalizer rails.

Reverse the Connect Boom Straps topic in Section 4 of the Crane Operator Manual.

9. Using an assist crane, disassemble the boom sections.

Reverse the Assemble Boom Inserts and Top topic in Section 4 of the Crane Operator Manual.
10. Using an assist crane, disconnect the boom butt from the crane as instructed in Section 4 of the Crane Operator Manual.

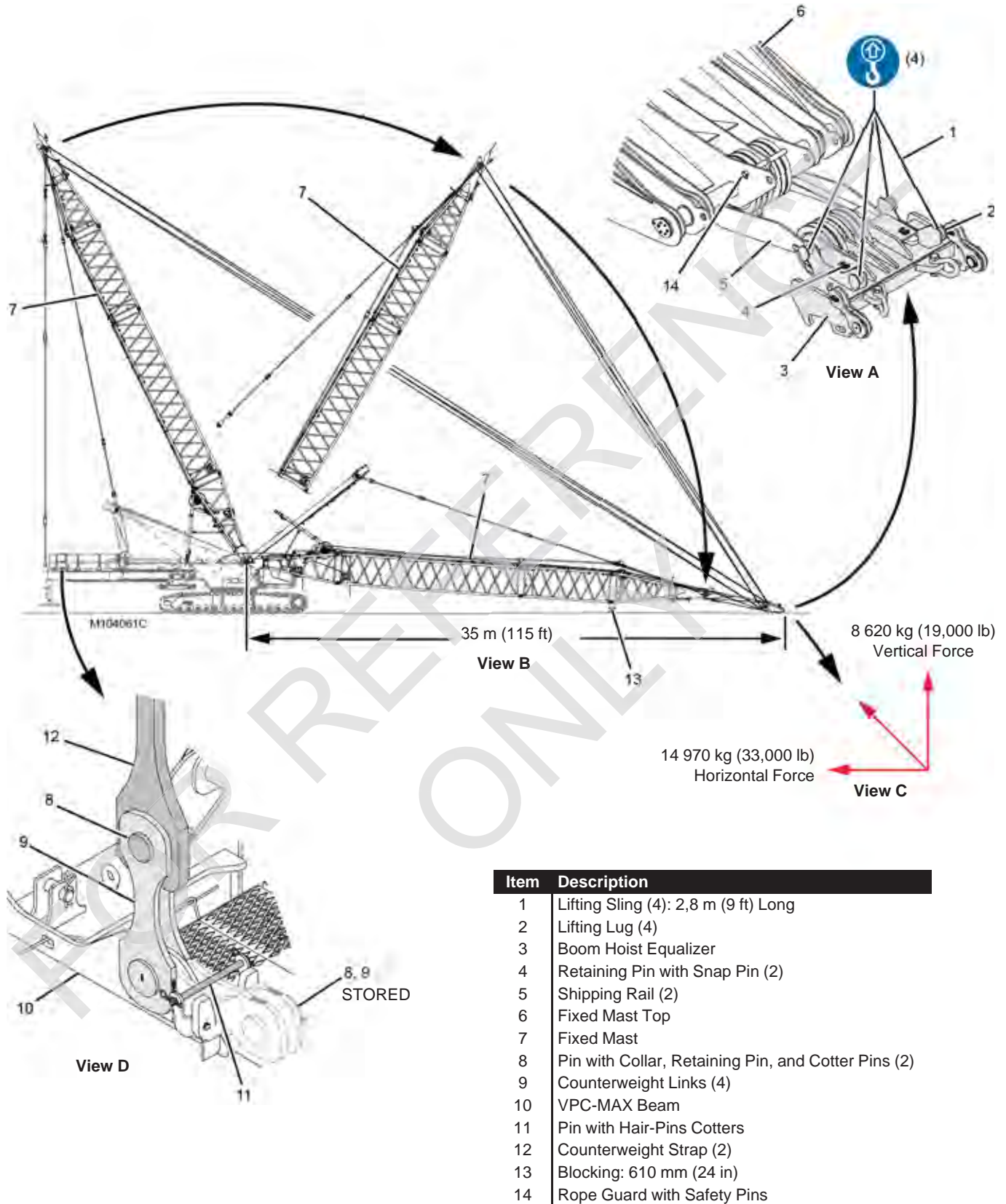

Figure 4-65

Anchor Boom Hoist Equalizer to Holdback

Anchor the boom hoist equalizer (3) to the desired holdback per the anchor holdback diagram in [Figure 4-65](#), View C.

Disconnect Counterweight Straps

See [Figure 4-65](#), View D for the following procedure.

- Using the Drum 4 and 5 control handles, slowly haul in the mast hoist wire rope and pay out boom hoist wire rope so the counterweight straps are slack.

This step will pull the fixed mast back to approximately 116° as indicated in the fixed mast working screen in the RCL/RCI display.

- Disconnect the counterweight straps from the counterweight links on one side of the mast at a time:
 - Attach a hand-held tagline approximately 9 m (30 ft) long to the counterweight strap (4).
The tagline will be used to guide the strap rearward by assembly personnel when the pin is removed in [step b](#).
 - Remove the pin (8) connecting the counterweight links (9) to the counterweight strap (12).
Repeat [step 1](#) as necessary to loosen the pins.
 - Pay out the hand-held tagline until the counterweight strap is hanging vertical.
 - Remove storage pin (11) from the storage bracket.
 - Rotate the counterweight links (9) forward onto the storage bracket.
 - Install storage pin (11).
 - Reinstall the pin (8) in the counterweight links (9).
 - Repeat the steps on the other side of the fixed mast.
 - Leave the taglines attached to the counterweight straps.

Lower Fixed Mast

See [Figure 4-65](#) for the following procedure.

- Slowly boom up (haul in boom hoist wire rope) while paying out the mast hoist wire rope to raise the fixed mast (7) toward vertical.

The mast hoist wire rope must remain slack until the fixed mast nears vertical.

NOTE As the fixed mast rises, the crane control system monitors mast tension (right side only) and automatically slows down either Drum 4 or Drum 5 to maintain the constant target tension specified on [page 4-71](#).

The mast tension can be monitored in the Crane Status Bar of the Main Display (see View E, [Figure 4-44 on page 4-72](#)).

- Guide the counterweight straps around the live mast with the hand-held taglines and into the storage brackets on fixed mast.
- As the fixed mast nears vertical, tighten the mast hoist wire rope as required so the fixed mast moves smoothly forward past vertical.
- Continue to slowly pay out the mast hoist wire rope and haul in the boom hoist wire rope to lower the fixed mast toward the ground.
- Maintain slack in the boom hoist wire rope so the wire rope does not rub against the rope guard (14).

CAUTION

Avoid Mast Damage

Do not lower the fixed mast to more than 4° below horizontal. Damage to the mast hinge or rotating bed can occur.

- Continue the lowering process to lower the fixed mast onto blocking (13, View B) that is a minimum of 610 mm (24 in) high. Do not lower fixed mast to more than 4° below horizontal.

Connect Boom Hoist Equalizer to Mast Top

See [Figure 4-65](#), View A for the following procedure.

- Remove the retaining pins (4) from the boom hoist equalizer (3).
- Attach the lifting slings (1) to the lifting lugs (2) on the boom hoist equalizer (3) and to the hook of the assist crane.
- Lift the boom hoist equalizer onto the shipping rails (5) on the end of the mast top while hauling in the boom hoist wire rope.
- Install the retaining pins (4) to attach the boom hoist equalizer to the shipping rails (5).
- Disconnect the lifting slings from the boom hoist equalizer.

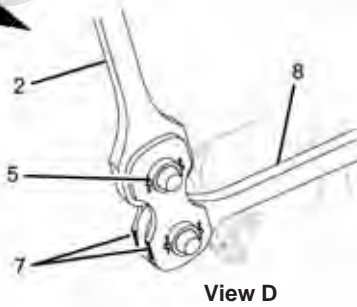
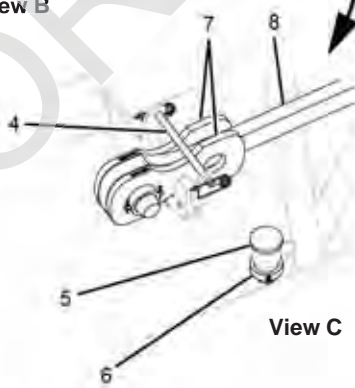
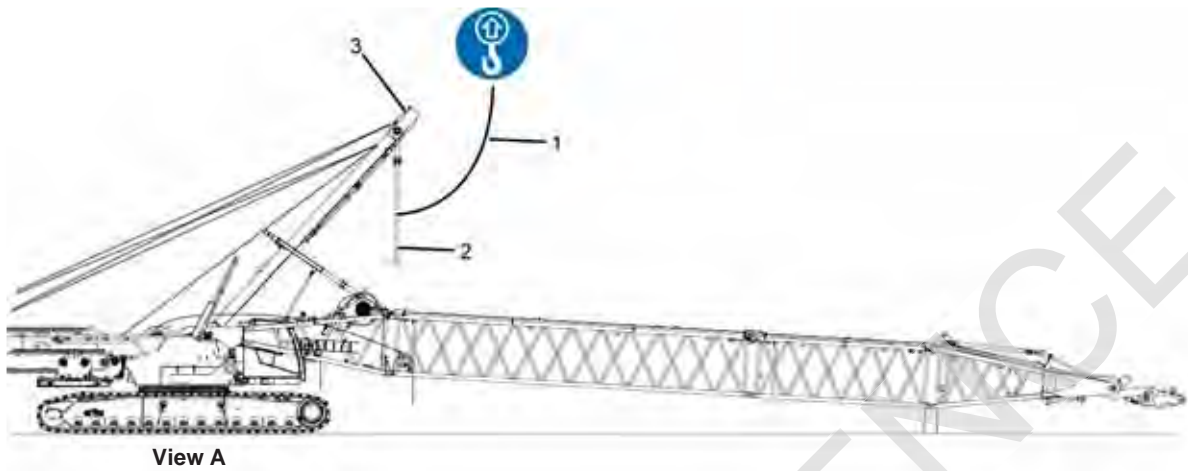

Figure 4-66

REMOVING VPC-MAX #503 FIXED MAST

Legend for [Figure 4-66](#)

Item	Description
1	Lifting Sling (2): 2,8 m (9 ft) Long
2	Live Mast Straps
3	Live Mast
4	Retaining Pin (2)
5	Pin with Collar, Retaining Pin, and Cotter Pins (2)
6	Tube (2)
7	Link (4)
8	Fixed Mast Strap (2)
9	Mast Assist Arm (2)
10	Fixed Mast Stop (2)

Raise Live Mast Assist Arms



DANGER

Falling Mast Hazard!

Prevent the live mast from falling:

- Fully raise the mast assist arms before attempting to raise the live mast toward vertical once the live mast straps are disconnected. The live mast will fall over backwards if the arms are not raised.

Using the switch on the remote control or on the right control console, fully RAISE the mast assist arms (9, View B).

NOTE When the Live Mast Configuration is ON, the following will occur if you attempt to raise the mast when the mast assist arms are down:



- The mast will stop rising.
- The hazard warning will come on and the MAST ASSIST ARMS DOWN icon will appear in the fault bar of the Main Display Working Screen.
- Make sure the mast assist arms are up before raising the mast.

Configure Live Mast in RCL/RCI

Enter the Live Mast Configuration in the RCL/RCI Display. Refer to the RCL/RCI Operation Manual for instructions.

Disconnect Live Mast Straps from Fixed Mast

See [Figure 4-66](#) for the following procedure.

- Remove the retaining pins (4, View C) from the brackets on the 12 m insert.
- Lower the live mast until the mast straps (8, View D) are resting in the brackets on the mast sections and the live mast is at approximately 154° as shown in View B.
- Using a choker hitch, connect the lifting slings (1, View B) to the mast straps (2).
- Remove the pins (5, View D) and rotate the links (7) to the shipping position (View C).
- Install the retaining pins (4, View C).
- Store the pins (5, View C).
- Attach a 9 m (30 ft) long hand-held tagline to the end of both fixed mast stops (10, View B).

CAUTION

Mast Damage!

The fixed mast stops can contact the live mast when the live mast is raised and lowered.

To avoid damage, use the hand-held taglines to pull the fixed mast stops away from the live mast as it is raised and lowered.

- While following with the assist crane, raise the live mast (3) until the live mast straps are vertical as shown in View A.
- Disconnect the lifting slings from the live mast straps.

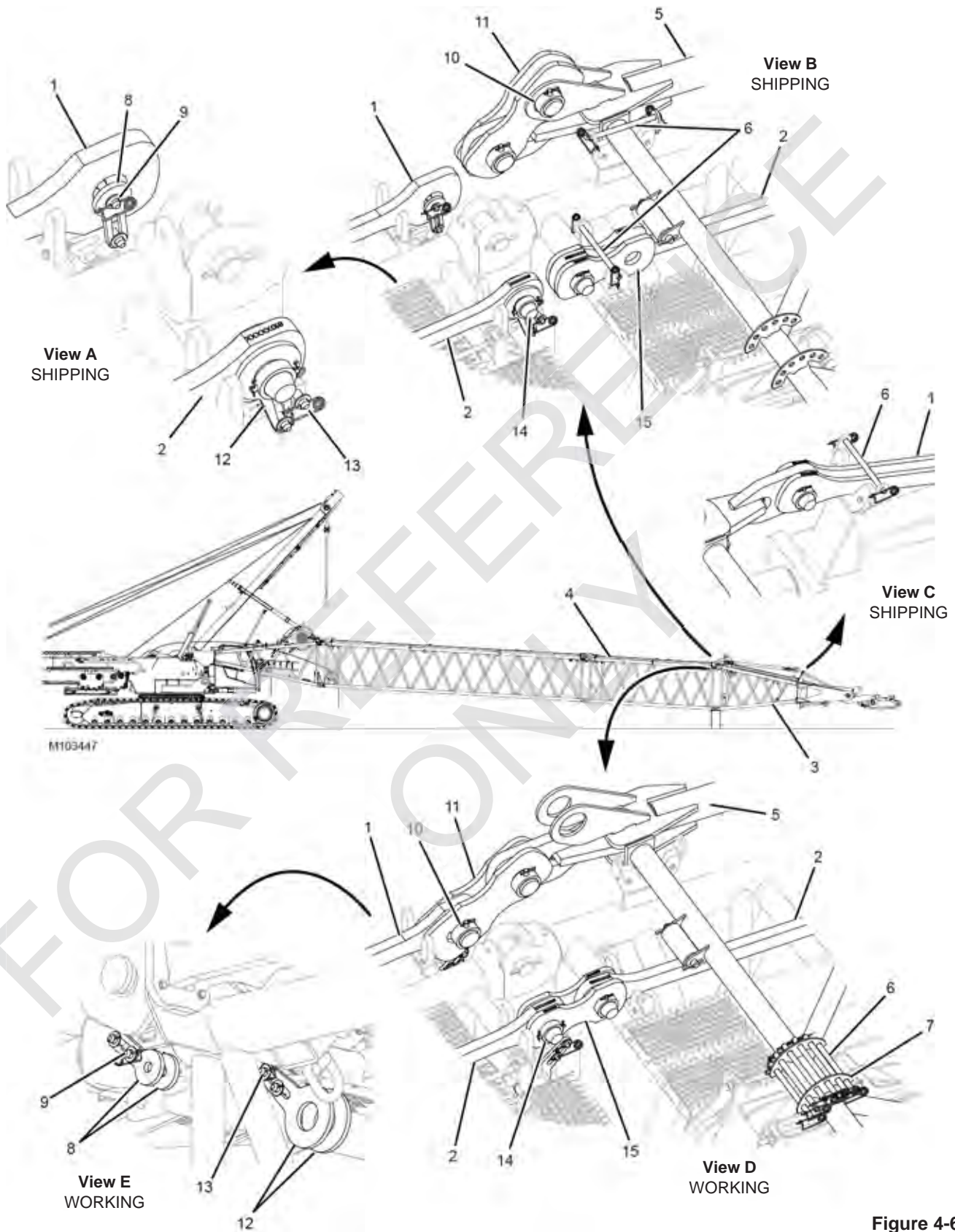

Figure 4-67

Legend for [Figure 4-67](#)

Item	Description
1	Counterweight Strap (2)
2	Mast Strap (4)
3	Mast Top
4	Mast Insert (6 m)
5	Spreader Beam
6	Retaining Pin with Hair-Pin Cotters (6)
7	Bracket
8	Strap Bracket (4)
9	Pin with Hair-Pin Cotters and Flat Washers (4)
10	Pin with Collar, Retaining Pin, and Cotter Pins (2)
11	Link (4)
12	Strap Bracket (4)
13	Pin with Hair-Pin Cotters and Flat Washers (2)
14	Pin with Collar, Retaining Pin, and Cotter Pins (2)
15	Link (4)

Disconnect and Store Straps at Mast Top

See [Figure 4-67](#) for the following procedure.

- Remove the retaining pins (6, View D) from storage in the bracket (7) on the spreader beam (5).
- Install pins (6, Views B and C) to secure the spreader beam (5) and the counterweight straps (1) in the shipping position.
- Remove the pin (10, View D) from the working position.
- Rotate the links (11, View D) forward from the working position to the shipping position (View B).
- Install the pin (10, View B). The PIN HEAD MUST FACE OUT (collar facing center of mast section).
- Unpin the strap brackets (8, View E) from the working position and pin them in the shipping position (View A).
- Remove the pin (14, View D) from the working position.
- Rotate the links (15, View D) forward from the working position to the shipping position (View B) and install pin (6).
- Unpin the strap brackets (12, View E) from the working position and pin them in the shipping position (View A).
- Install the pin (14, View B). The PIN HEAD MUST FACE OUT (collar facing center of mast section).
- Repeat the steps for the straps on the other side of mast top.

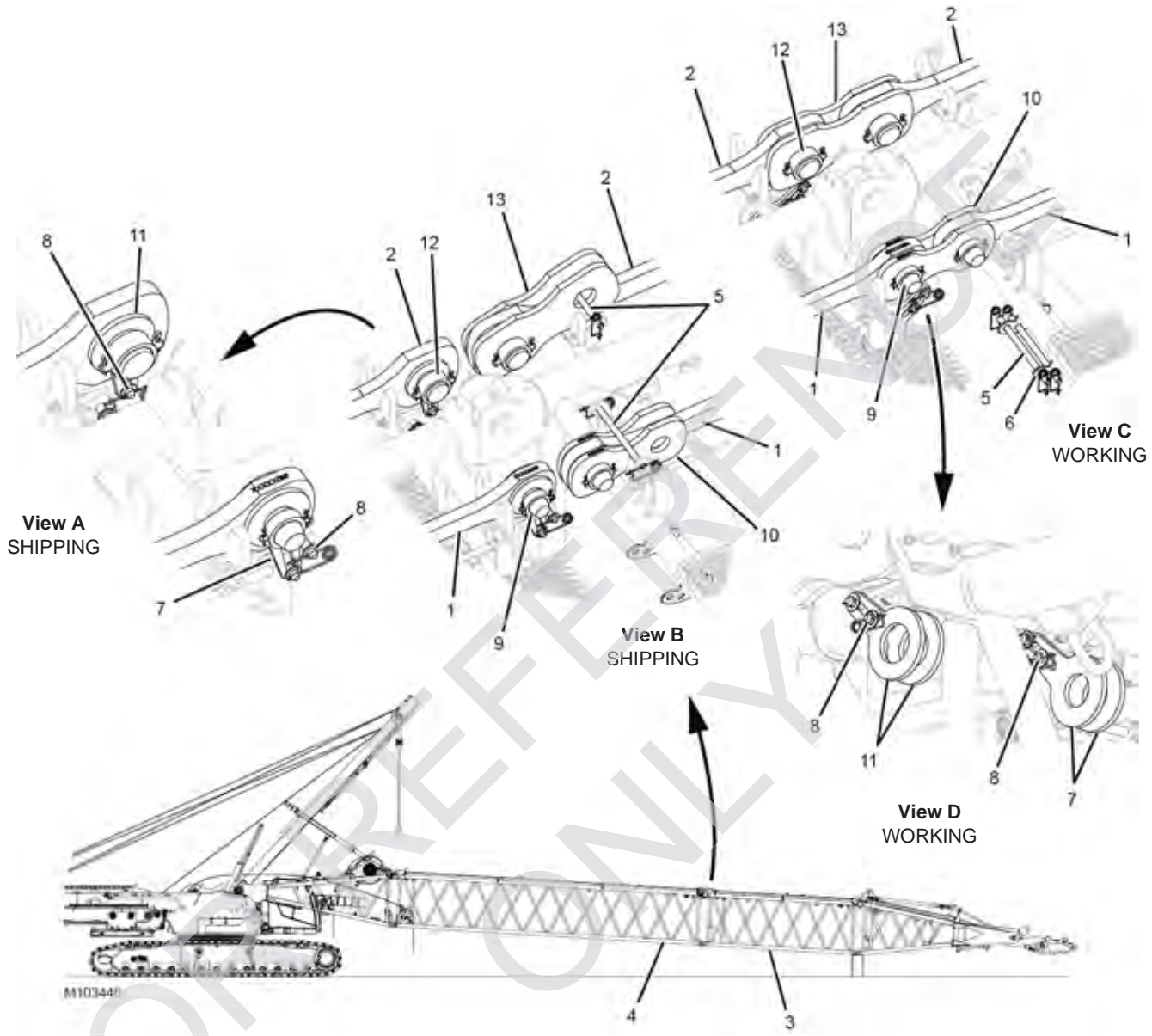

Figure 4-68

Legend for [Figure 4-68](#)

Item	Description
1	Mast Strap (4)
2	Counterweight Strap (4)
3	Mast Insert (6 m)
4	Mast Insert (12 m)
5	Retaining Pin with Hair-Pin Cotters (6)
6	Bracket
7	Strap Bracket (4)
8	Pin with Hair-Pin Cotters and Flat Washers (8)
9	Pin with Collar, Retaining Pin, and Cotter Pins (2)
10	Link (4)
11	Strap Bracket (4)
12	Pin with Collar, Retaining Pin, and Cotter Pins (2)
13	Link (4)

Disconnect and Store Straps at Mast Inserts

See [Figure 4-68](#) for the following procedure.

- Remove the retaining pins (5, View C) from storage in the brackets (6) on the 6 m insert (3).
- Remove the pin (9, View C) from the working position.
- Rotate the links (10, View C) forward from the working position to the shipping position (View B) and install pin the (5).
- Unpin the strap brackets (7, View D) from the working position and pin them in the shipping position (View A).
- Install the pin (9, View B). The PIN HEAD MUST FACE OUT (collar facing center of mast section).
- Remove the pin (12, View C) from the working position.
- Rotate the links (13, View C) forward from the working position to the shipping position (View B) and install pin the (5).
- Unpin the strap brackets (11, View D) from the working position and pin them in the shipping position (View A).
- Install the pin (12, View B). The PIN HEAD MUST FACE OUT (collar facing center of mast section).
- Repeat the steps for the straps on the other side of the mast inserts.

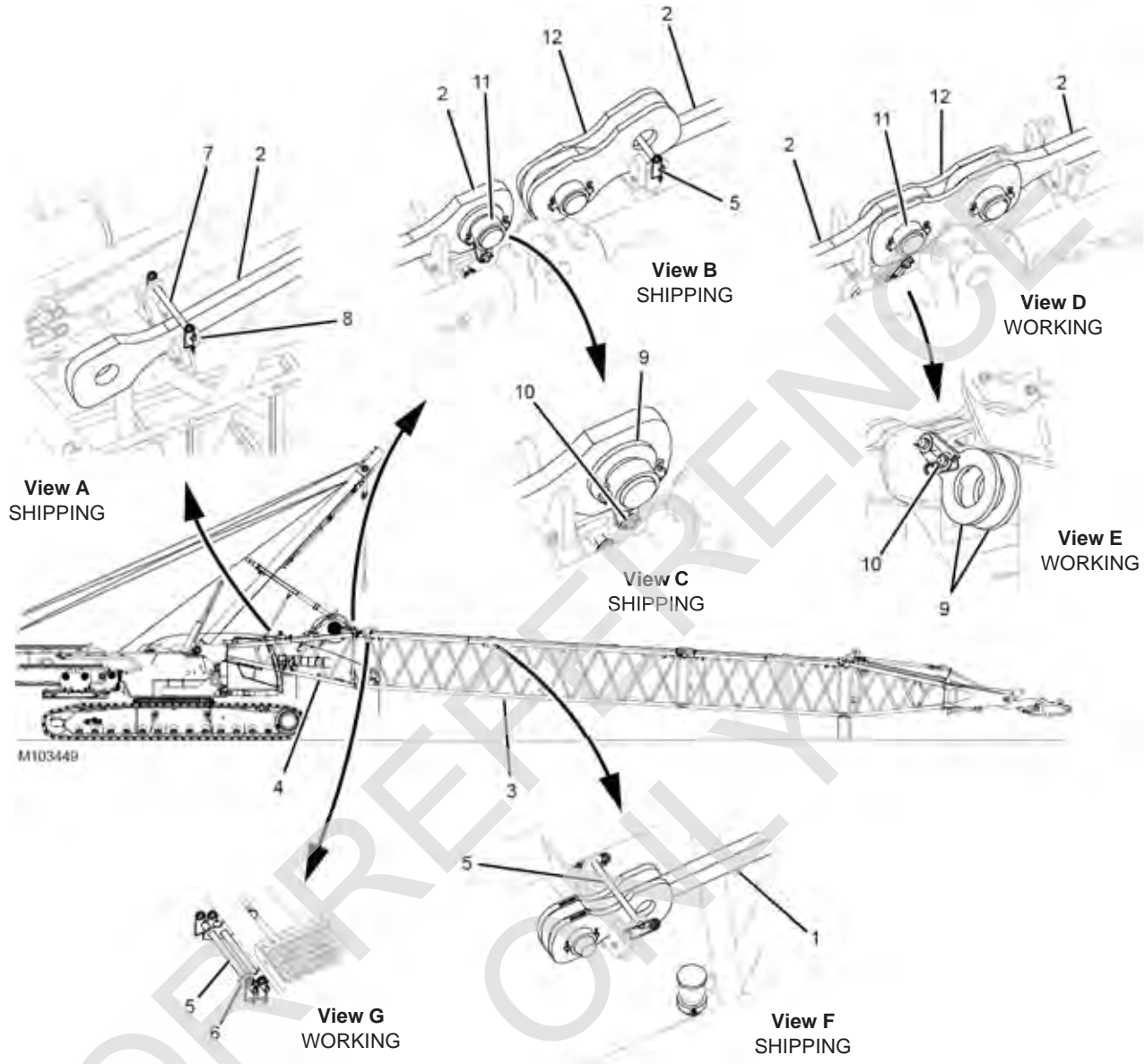

Figure 4-69

Legend for [Figure 4-69](#)

Item	Description
1	Mast Strap (2)
2	Counterweight Strap (2)
3	Mast Insert (12 m)
4	Mast Butt
5	Retaining Pin with Hair-Pin Cotter (4)
6	Bracket
7	Retaining Pin with Hair-Pin Cotter (2)
8	Bracket
9	Strap Bracket (4)
10	Pin with Hair-Pin Cotter and Flat Washers (8)
11	Pin with Collar, Retaining Pin, and Cotter Pins (2)
12	Link (4)

Disconnect and Store Straps at Mast Butt

See [Figure 4-69](#) for the following procedure.

1. Remove the retaining pin (7, View A) from storage and install it in the shipping position over the counterweight strap (2) in the bracket (8).
2. Remove the retaining pins (5, View G) from storage in the brackets (6) on the end of the 12 m insert (3).
3. If not already done, install pins (5, View F) to secure the mast straps (1) in the shipping position.
4. Remove the pin (11, View D) from the working position.
5. Rotate the links (12, View D) forward from the working position to the shipping position (View B) and install pin the (5).
6. Unpin the strap brackets (9, View E) from the working position and pin them in the shipping position (View C).
7. Install the pin (11, View B). The PIN HEAD MUST FACE OUT (collar facing center of mast section).
8. Repeat the steps for the straps on the other side of the mast butt.

Item	Description
1	Live Mast
2	Self-Erect Cylinder
3	Handling Pendants (2)
4	Mast Assist Arms (2)
5	Lifting Link
6	Storage Lugs
7	Live Mast Straps (2)
8	Fixed Mast Insert

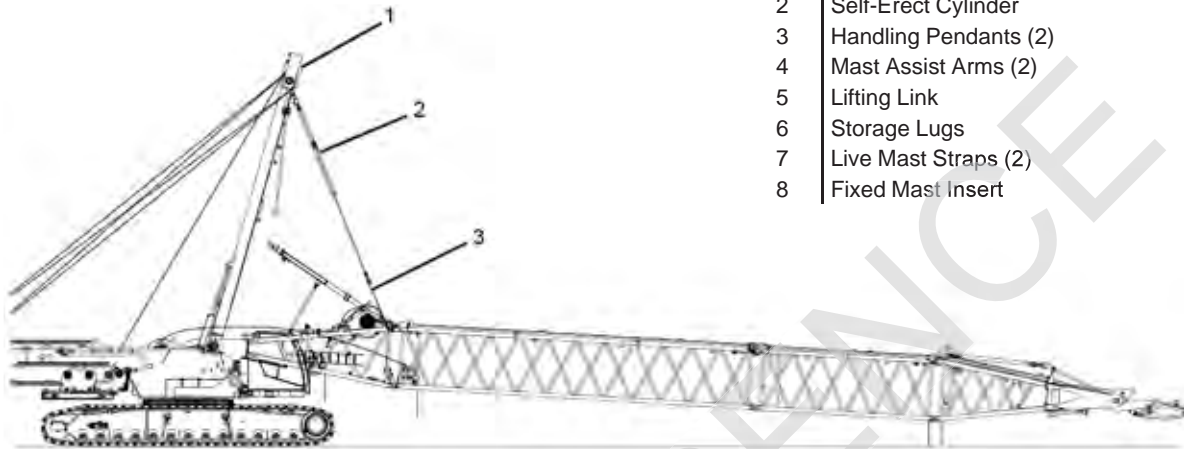

View A

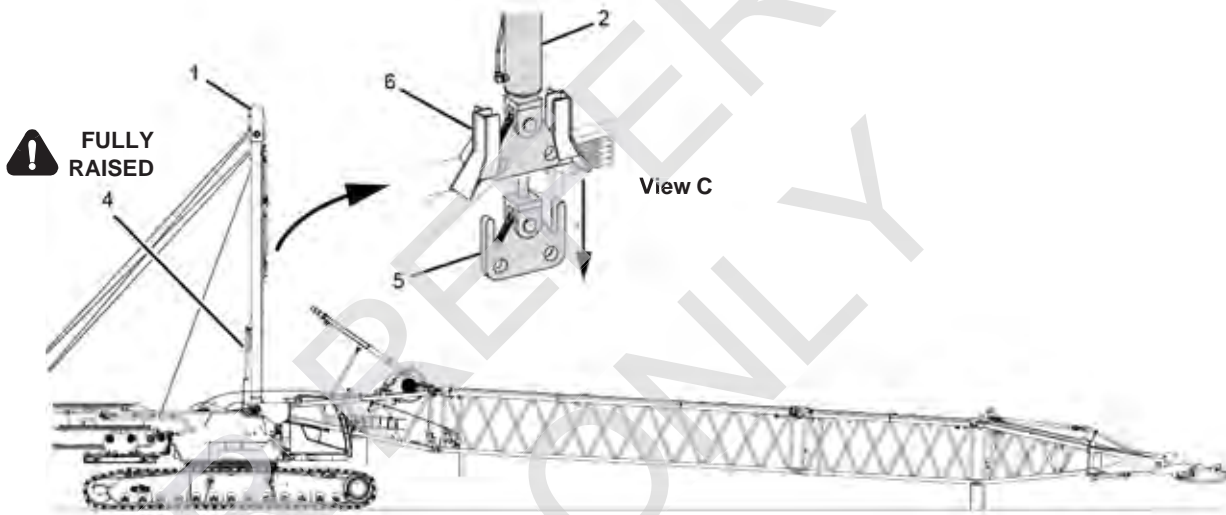

View B

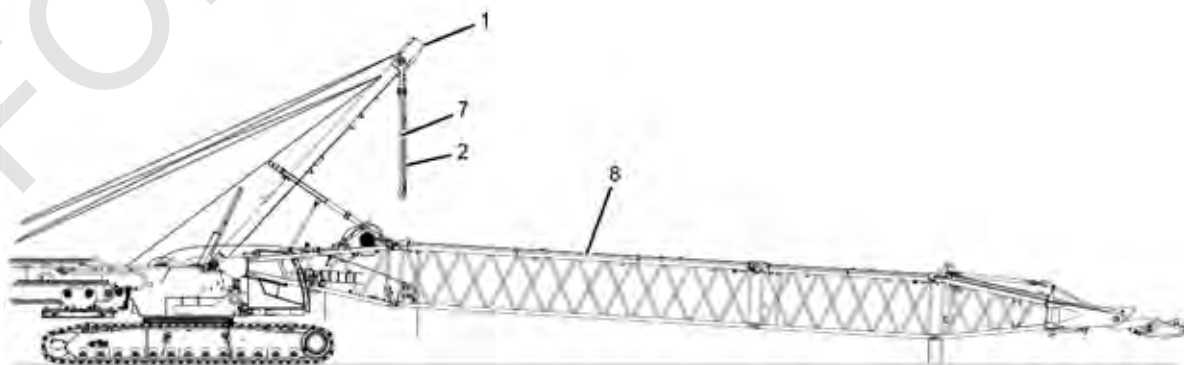

View D

M103427A

Figure 4-70

Deploy Self-Erect Cylinder

See [Figure 4-70](#) for the following procedure.

1. Confirm that the mast assist arms (4, View B) are fully raised before proceeding.

NOTE When the Live Mast Configuration is ON, the following will occur if you attempt to raise the live mast when the mast assist arms are down:

- The live mast will stop rising.
- The hazard warning will come on and the MAST ASSIST ARMS DOWN icon will appear in the fault bar of the Main Display Working Screen.
- Make sure the mast assist arms are up before raising the live mast to vertical.



2. **To avoid damage**, use the hand-held taglines to guide the fixed mast stops clear of the live mast as it is raised and lowered during the following steps.
3. Raise the live mast (1, View B) to vertical.
4. Turn on the self-erect cylinder in the Self-Erect Cylinder Selection Screen in the Main Display.
5. Slowly extend the self-erect cylinder (2, View C) until the lifting link (5) disengages the storage lugs (6).

6. Lower the live mast (1, View D) until the self-erect cylinder (2) is hanging vertical over the handling pendants (3, View A).

Connect Handling Pendants

1. Disconnect the handling pendants from storage and connect them to the self-erect cylinder as shown in View A, [Figure 4-33 on page 4-52](#).

Lower the live mast and extend the self-erect cylinder as needed to make the connection.

2. **To avoid damage**, use the hand-held taglines to guide the fixed mast stops clear of the live mast as it is raised.
3. Raise the live mast (1, View A) and fully extend the self-erect cylinder (2) until the handling pendants (3) are tight.

CAUTION

Mast Damage!

Do not attempt to raise the fixed mast with the live mast self-erect cylinder until the fixed mast top is removed. Damage to the cylinder or live mast may occur.

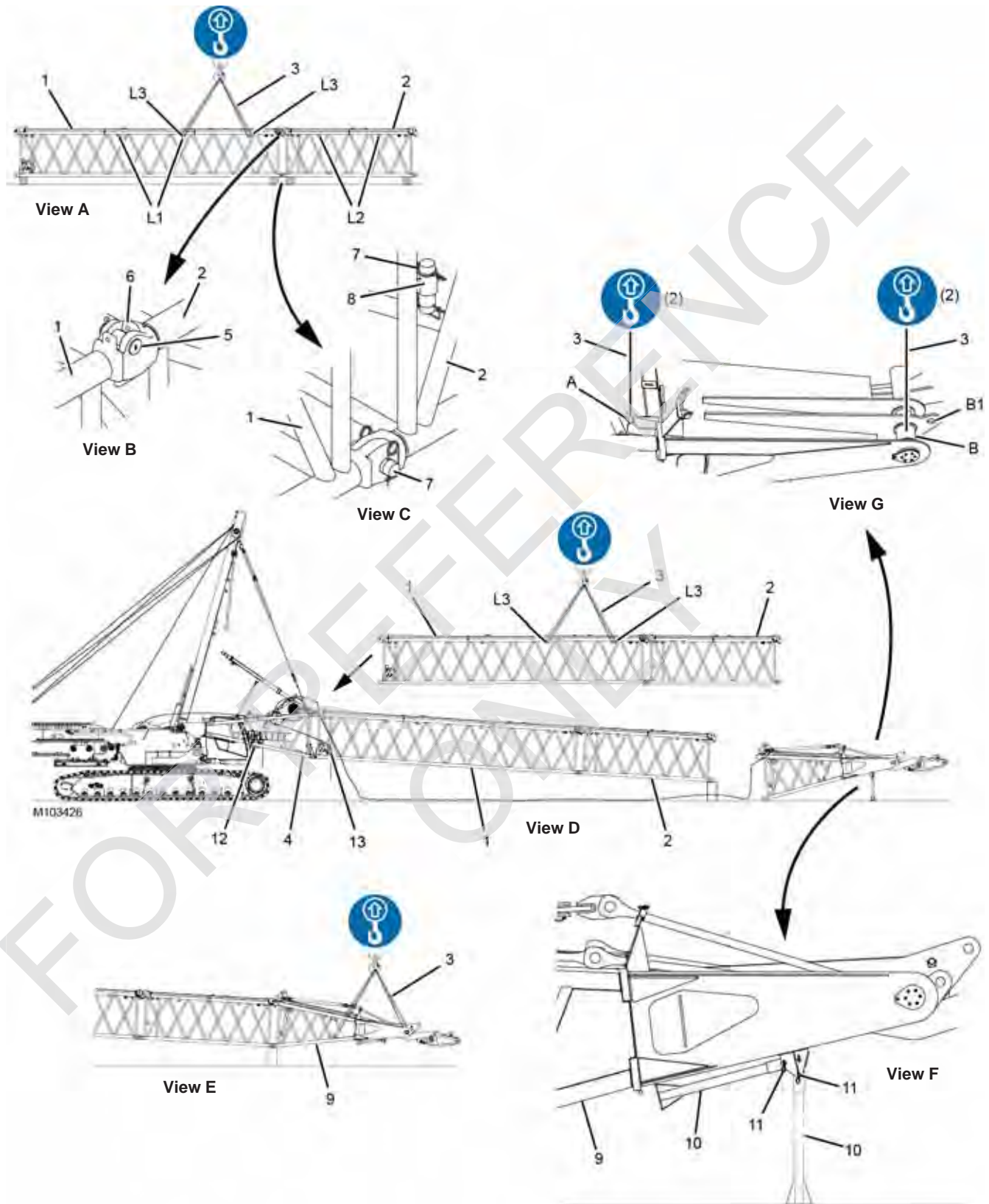

Figure 4-71

Legend for [Figure 4-36](#)

Item	Description
1	Insert: 12 m (39.4 ft)
2	Insert: 6 m (19.7 ft)
3	Lifting Sling (4): 2,8 m (9 ft) Long OR Lifting Sling (4): 4 m (13 ft) Long
4	Fixed Mast Butt
5	Fixed Horizontal Pin (2)
6	Hooked Connector (2)
7	Pin with Safety Pins (2)
8	Tube (2)
9	Fixed Mast Top
10	Support (2)
11	Pin with Hair-Pin Cotter (2)
L1	Lifting Lug (4, for lifting 12 m insert)
L2	Lifting Lug (4, for lifting 6 m insert)
L3	Lifting Lug (4, for lifting 12m and 6 m inserts)

Store Load Lines

If not already done, haul in the load lines for Drums 2 and 3 from the sheaves in the mast butt (4). Secure the load lines to the drums.

Remove Fixed Mast Top

See [Figure 4-71](#) for the following procedure.

- Using chocker hitches, attach the lifting slings (3, View G) to the lifting points (A and B) in the fixed mast top and to the hook of the assist crane.

NOTE As an alternative to the chocker hitches, the lifting slings (4) can be attached to owner furnished shackles. Attach the shackles to the lifting points (A and B1, View G).

- Deploy the fixed mast top supports (10, View F):
 - Remove pins (11).
 - Rotate the supports (10) down to the shipping position.
 - Install pins (11).

- Tighten the lifting slings, and remove the pins (7, View C) from between the fixed mast top and insert.
- Store the pins (7, View C) in the tubes (8) on the fixed mast top.
- Lift the fixed mast top off the end of the insert.
- Pay out the boom hoist wire rope and place the mast top on the ground in front of the inserts as shown in View D.
- Disconnect the lifting slings from the mast top.
- Lift the boom hoist wire rope off the top of the inserts and lay the wire rope on the ground along either side of the inserts.

Remove and Disassemble Fixed Mast Inserts

See [Figure 4-71](#) for the following procedure.

- Connect the lifting slings (3, View A) to the hook of the assist crane and to the lifting lugs (L3) on the insert (1).
- The assembled inserts (1 and 2, View D) can be cantilevered from the fixed mast butt (4).
- Tighten the lifting slings, and remove the pins (7, View C) from between the insert (1) and the fixed mast butt (4).
- Store the pins (7, View C) in the tubes (8) on the insert.
- Lift the inserts off the end of the fixed mast butt.
- Place the inserts on blocking as shown in View A.
- Disconnect the lifting slings from the insert (1).
- Connect the lifting slings (3, View A) to the lifting lugs (L2) on the insert (2).
- Tighten the lifting slings, and remove the pins (7, View C) from between the inserts.
- Store the pins (7, View C) in the tubes (8) on the insert.
- Lift the insert (2) away from the insert (1).
- Lift the inserts onto trailers and secure them for shipping or store the inserts on the job site.

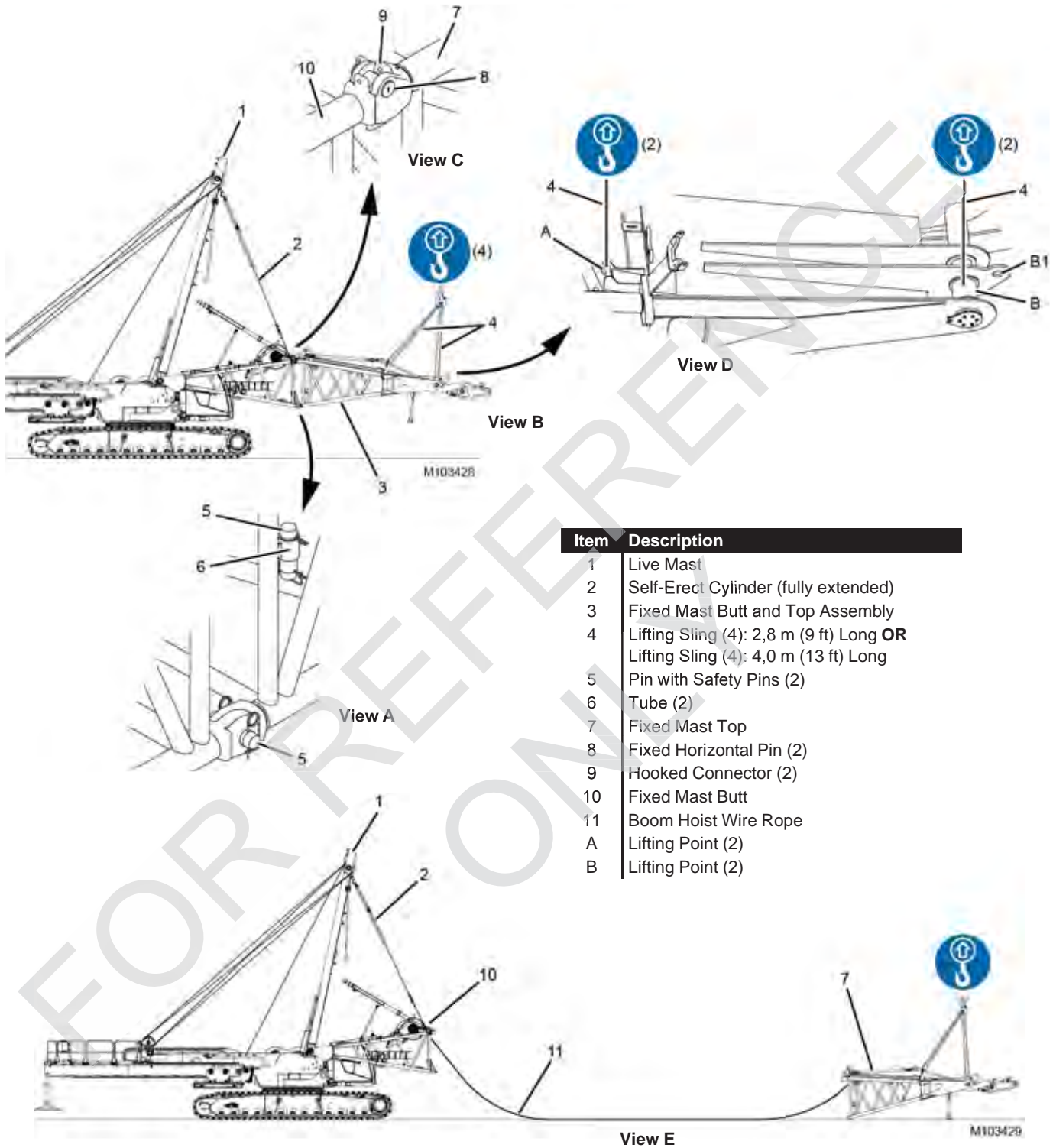

Figure 4-72

Connect Fixed Mast Top to Fixed Mast Butt

See [Figure 4-35](#) for the following procedure.



WARNING

Falling Load Hazard!

Do not allow assembly personnel to walk on the fixed mast butt and top assembly until after [step 1](#) and [step 2](#) are performed.

The assembly personnel can fall or be thrown off the fixed mast butt and top assembly if this precaution is not taken.

1. Raise the live mast (1, View E) and extend the self-erect cylinder (2) until the cylinder is fully extended and the centerline of the mast butt (10) is at horizontal.
 2. Place the Drum 4 park switch on the front control console in the PARK position. This step will apply the Drum 4 brake and engage the drum pawl.
 3. Using chocker hitches, attach the lifting slings (4, View D) to the lifting points (A and B) in the fixed mast top and to the hook of the assist crane.
- NOTE** As an alternative to the chocker hitches, the lifting slings (4) can be attached to owner furnished shackles. Attach the shackles to the lifting points (A and B1, View D).
4. Assembly personnel **must not be on the fixed mast butt and top assembly** until after [step 8](#) is performed.
 5. Haul in the wire rope on Drum 5 in the fixed mast butt while performing [step 6](#).
 6. Using the assist crane, lift the fixed mast top (7, View E) into position so the fixed horizontal pins (8, View C) in the fixed mast top engage the hooked connectors (9) on the fixed mast butt (10).
 7. Lower the fixed mast top until the bottom connecting holes are aligned.
 8. Remove the pins (5, View A) from the tubes (6) and install the pins in the bottom connecting holes.
 9. Disconnect the lifting slings (4, View D) from the assist crane and from the lifting lugs on the fixed mast top.

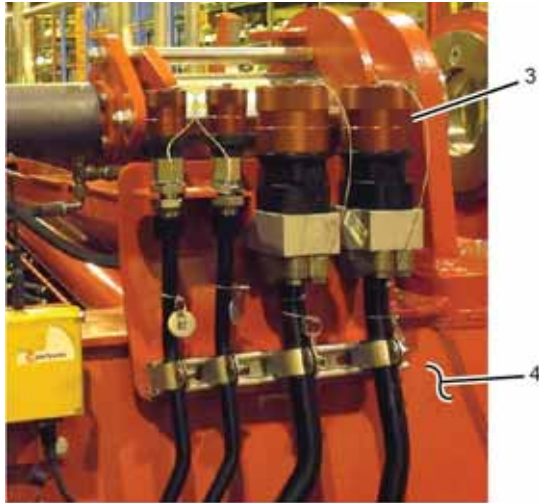

M103727

View A
PAST

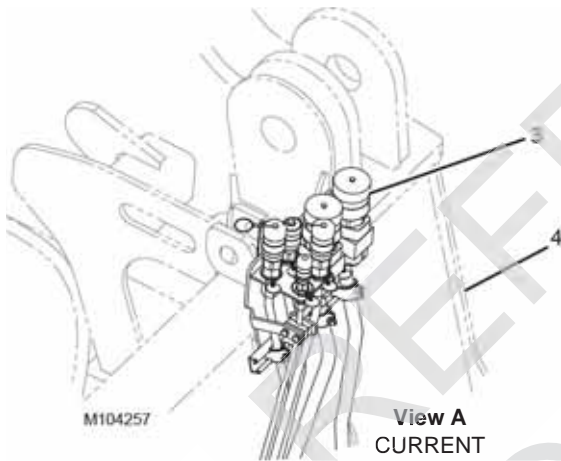

M104257

View A
CURRENT

Item	Description
1	Hydraulic Hoses (4 or 6)
2	Storage Couplers (4 or 6)
3	Hydraulic Couplers (4 or 6 with dust caps)
4	Left Side of Rotating Bed
5	Electric Cable with Dust Cap
6	Electric Receptacle with Dust Cap
7	Junction Box (right side of rotating bed)
8	Drum 5 Camera Cable with Dist Cap
9	VPC-MAX Camera Cable with Dist Cap
10	Camera Switcher with Dist Caps



M103728

View B



M104266

View D

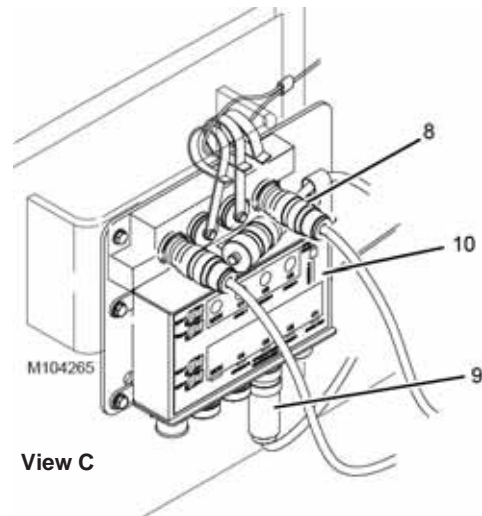

M104265

View C

Figure 4-73

Disconnect Fixed Mast Hydraulic Hoses

See [Figure 4-73](#) for the following procedure.

1. Disconnect the hydraulic hoses (1) from the hydraulic couplers (3, View A) on the left side of the rotating bed (4).
2. Thoroughly clean and lubricate the hydraulic nipples, the couplers, and the dust caps.
3. Connect the dust caps to the hydraulic couplers (3, View A).
4. Connect the hydraulic hoses (1, View D) to the storage couplers (2) on the fixed mast butt.

Disconnect Fixed Mast Electric Cable

See [Figure 4-73](#) for the following procedure.

1. Disconnect the electric cable (5) from the receptacle (6, View B) on the junction box (7) on the right side of the rotating bed.

2. Thoroughly clean the end of the electric cable, the receptacle, and the dust caps.

3. Connect a dust cap to the electric cable (5) and to the receptacle (6).

4. Coil and attach the electric cable (5, View D) to the fixed mast butt with a wire tie.

Disconnect Fixed Mast Camera Cables

See [Figure 4-73](#) for the following procedure.

1. Disconnect the camera cables (8 and 9, View C) from the receptacles on the camera switcher (10).

2. Thoroughly clean the ends of the camera cables, the receptacles on the camera switcher, and the dust caps.

3. Connect a dust cap to each camera cable and receptacle.

4. Coil and attach the camera cables (8 and 9, View D) to the fixed mast butt with a wire tie.

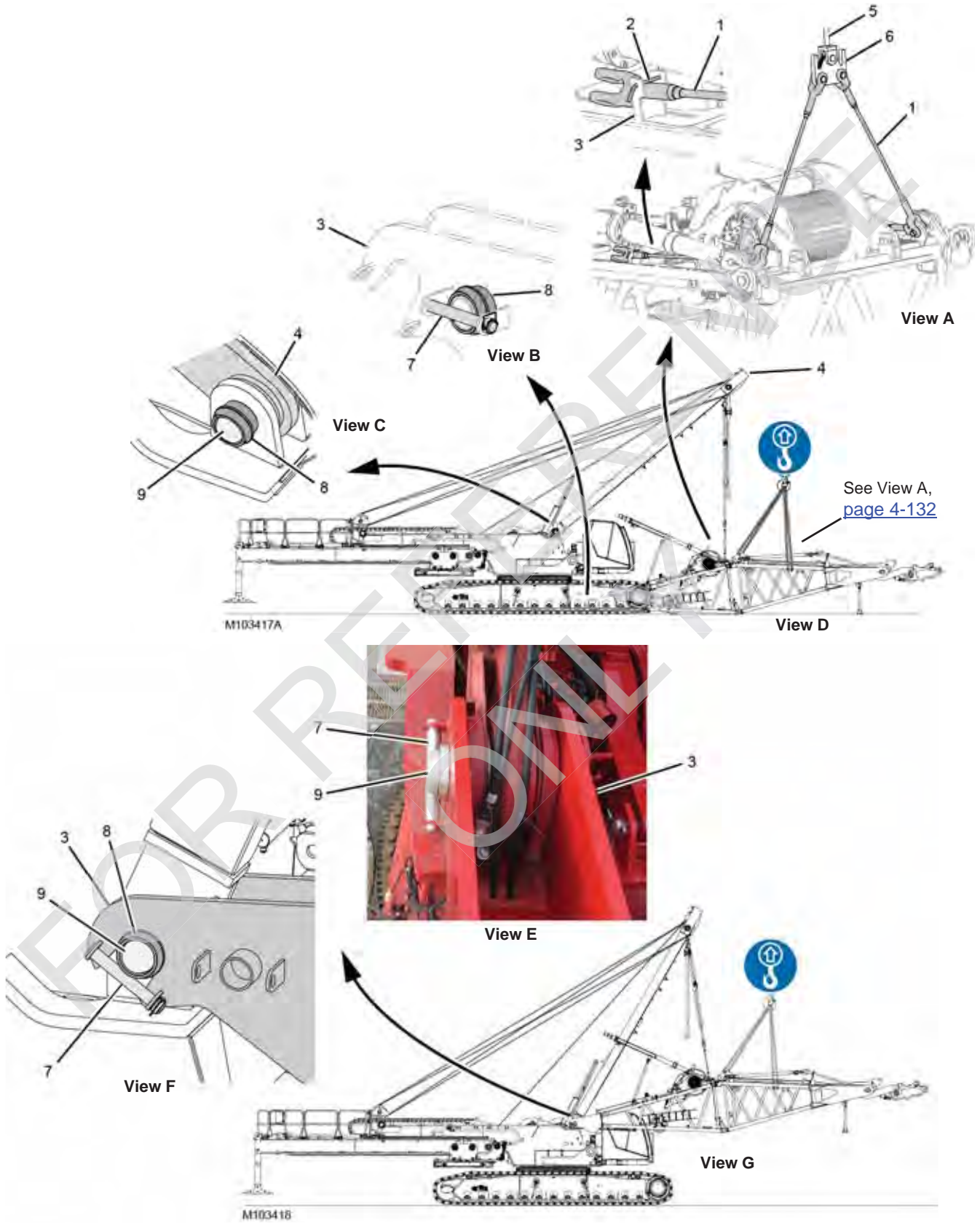

Figure 4-74

Legend for [Figure 4-74](#)

Item	Description
1	Handling Pendant (2)
2	Hitch Pin with Hair-Pin Cotter (2)
3	Fixed Mast Butt
4	Live Mast
5	Self-Erect Cylinder
6	Lifting Link
7	Pin with Collar and Safety Pin (2)
8	Sleeve Assembly (2)
9	Mast Hinge Pin (2)

Disconnect Fixed Mast Butt and Top Assembly from Crane

1. Attach lifting slings from the assist crane to the mast top as shown in View A, [Figure 4-75 on page 4-132](#).

See [Figure 4-74](#) for the remaining steps.

2. Attach a tagline to the end of the fixed mast top so an assembler can assist in guiding the fixed mast butt and top assembly as it is lifted.
3. **To avoid damage**, use hand-held taglines to guide the fixed mast stops clear of the live mast as it is raised and lowered during the following steps.

4. Tighten the lifting slings from the assist crane and from the live mast so that the mast butt is loose on the bushing assemblies (8, View F).
5. Remove the pins (7, View F).
6. SLOWLY lift the fixed mast butt and top assembly away from the rotating bed with the assist crane while following with the live mast.
7. Guide the fixed mast butt clear of the platform on the front of the carbody.
8. Lower the fixed mast butt and top assembly onto the ground in front of the crane (View D)
9. Remove the sleeve assemblies (8, View C) from the mast hinge pins (9).
10. Store the sleeve assemblies (8, View B) and the pins (7).
11. Remove the pins (2, View A) from the lugs on the fixed mast butt (3).
12. Unpin the handling pendants (1, View A) from lifting link (6) and store the pendants in the brackets on the fixed mast butt (3) with pins (2).
13. Raise the live mast to approximately 140° and retract the self-erect cylinder as needed.
14. Disconnect the hand-held taglines from the fixed mast.

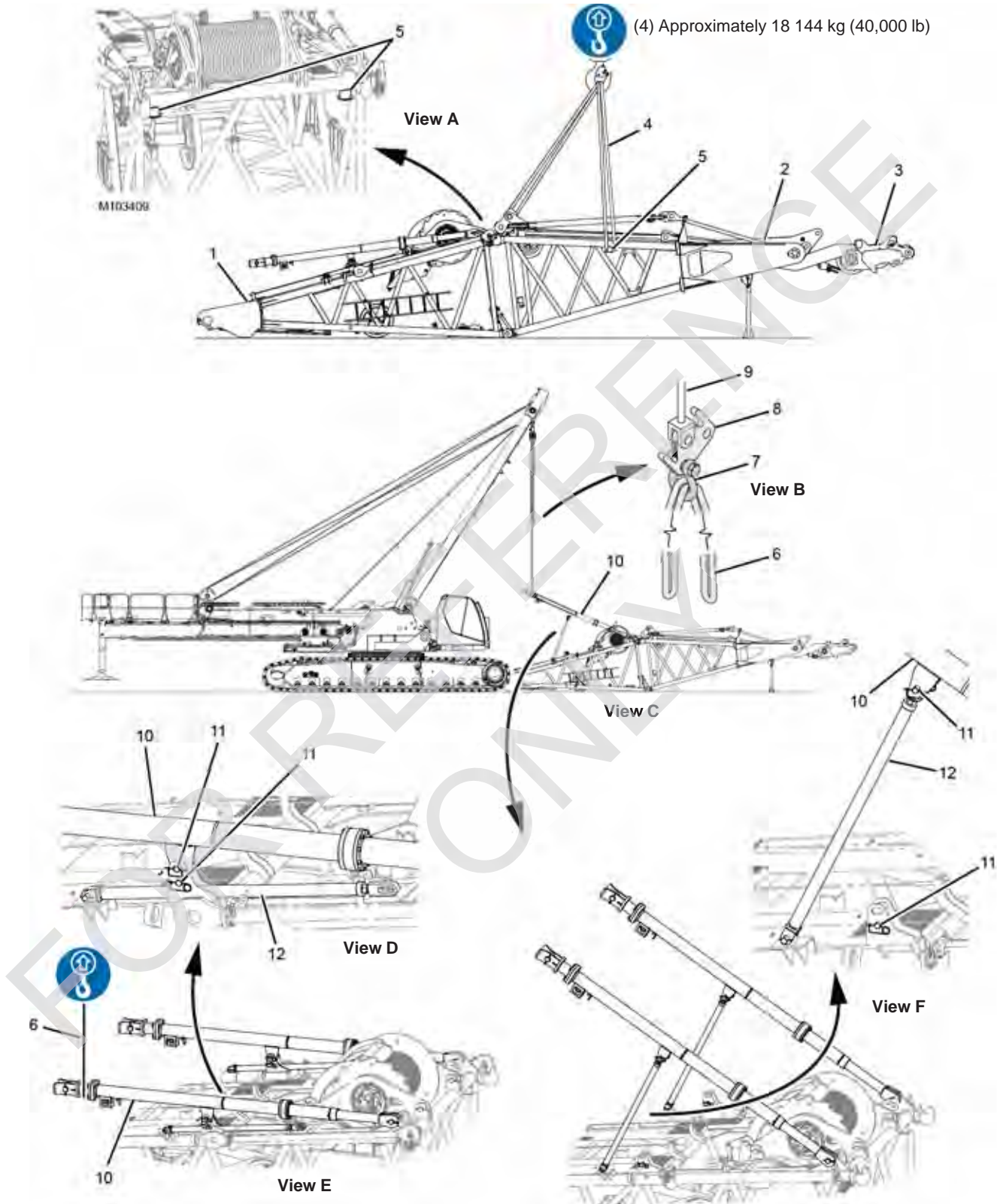

Figure 4-75

Legend for [Figure 4-31](#)

Item	Description
1	Fixed Mast Butt
2	Fixed Mast Top
3	Boom Hoist Equalizer
4	Lifting Sling (4): 2,8 m (9 ft) Long
5	Lifting Lug (4)
6	Lifting Sling (4): 4 m (13 ft) Long
7	Shackle: 25 t (28 USt)
8	Lifting Link
9	Self-Erect Cylinder
10	Mast Stop (2)
11	Pin with Safety Pin (4)
12	Strut (2)

Lower Mast Stops

See [Figure 4-75](#) for the following procedure.

1. Connect the shackle (7, View B) and the lifting sling (6) to the lifting link (8) on the self-erect cylinder (9).
2. Connect the ends of the lifting sling (6, View C) to the mast stop (10) and tighten the sling so the top pin (11, View F) is loose.
3. Remove the bottom and top pins (11, View F) and lower the strut (12), by hand, to the shipping position (View D).
4. Install the bottom pin (11, View D) to secure the strut (12) to the lugs on mast butt.
5. Lower the mast stop (10, View D) to the shipping position and install the top pin (11) to connect the mast stop to the lugs on the mast butt.
6. Disconnect the lifting sling from the mast stop.
7. Repeat the [step 2](#) through [step 6](#) for the other mast stop.
8. Disconnect the shackle (7, View B) and lifting sling (6) from the lifting link (8).

Install Fixed Mast Butt and Top Assembly on Trailer

See [Figure 4-75](#) for the following procedure.

The fixed mast butt (1), fixed mast top (2), and boom hoist equalizer (3) are shipped assembled as shown in View A.

1. Attach lifting slings (4, View A) to the hook of the assist crane and to the lifting lugs (5) on the fixed mast butt (1) and the fixed mast top (2).
2. Lift the fixed mast butt and top assembly onto the trailer and secure it for shipping.
3. Otherwise, store the fixed mast butt and top assembly on the job site.

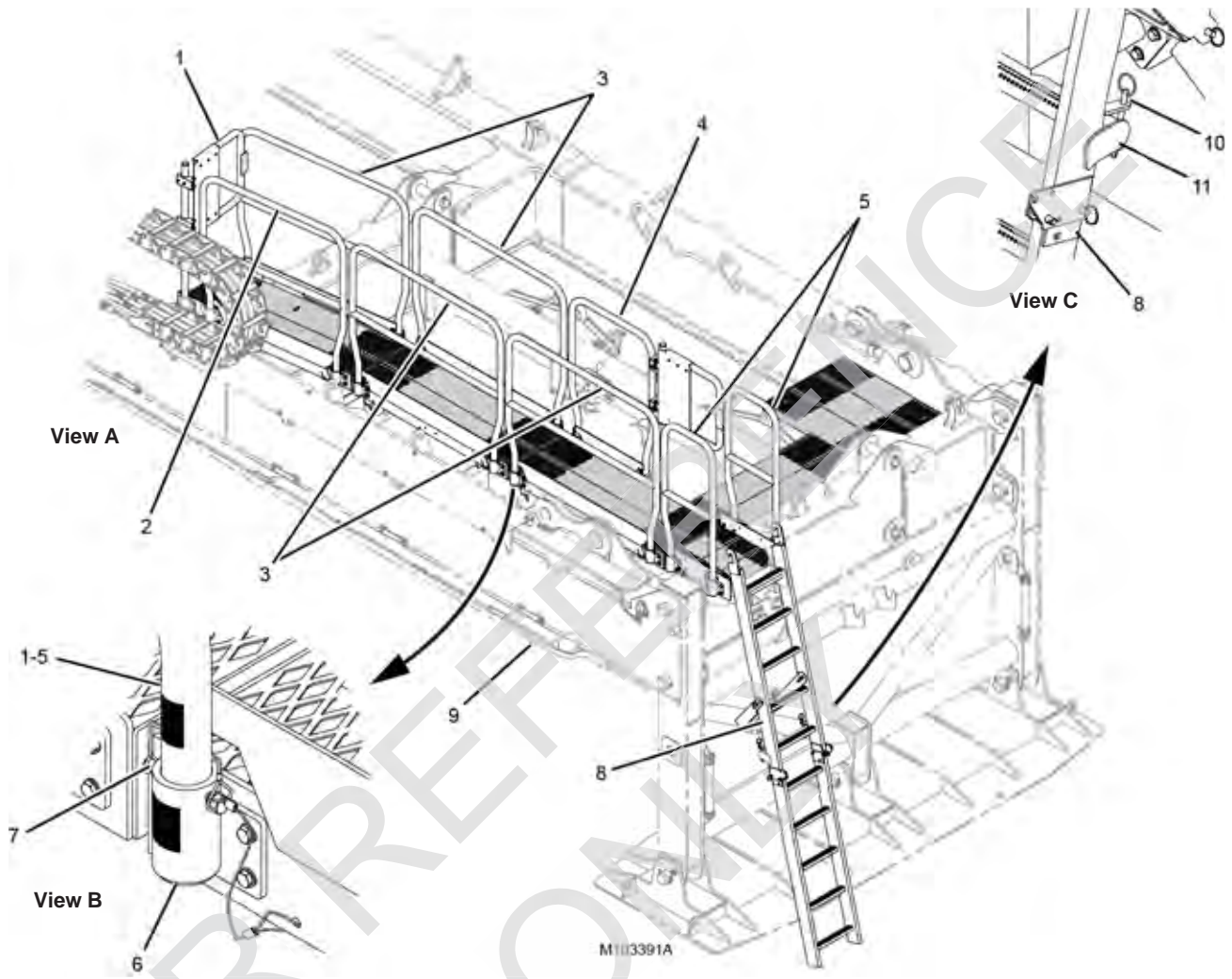

Item	Description	Item	Description
1	Handrail with Safety Barricade	7	Safety Pin (1 or 2 each handrail)
2	Handrail	8	Ladder (from crane)
3	Handrail (4)	9	VPC-MAX Beam
4	Handrail with Safety Barricade	10	Quick-Release Pin (2)
5	Handrail (2)	11	Auxiliary Frame Assembly
6	Platform Assembly		

Figure 4-76

REMOVING VPC-MAX BEAM AND TROLLEY

Remove Handrails

See [Figure 4-76](#) for the following procedure.

1. If necessary, install ladder (8, View A) to access the platform on the top of the VPC-MAX beam (9):
 - a. Hook the top rung of the ladder onto the hooked lugs at the rear of the platform.
 - b. Install the quick-release pins (10, View C) to secure the ladder (8) to the auxiliary frame assembly (11).
2. Remove the safety pins (7, View B) securing the handrail to the pockets on the platform assembly (6).
3. Lift the handrail (1-5) out of the pockets in the platform assembly (6, View B).
4. Using a hand-held tagline, lower the handrail (1-5) to ground level.

The heaviest handrail weighs 10 kg (22 lb).
5. Repeat the steps until all handrails (1-5) are removed.
6. Move the handrails to a safe location. They will be stored in the VPC-MAX beam later.
7. Reinstall the safety pins (7, View B) in the pockets on the platform assembly (6).
8. Remove the quick-release pins (10, View C) and remove the ladder (8).
9. Store the quick-release pins (10, View C) in the ladder lugs.
10. Move the ladder to a safe location. It can be installed on the rear of the rotating bed after the VPC-MAX beam is removed.

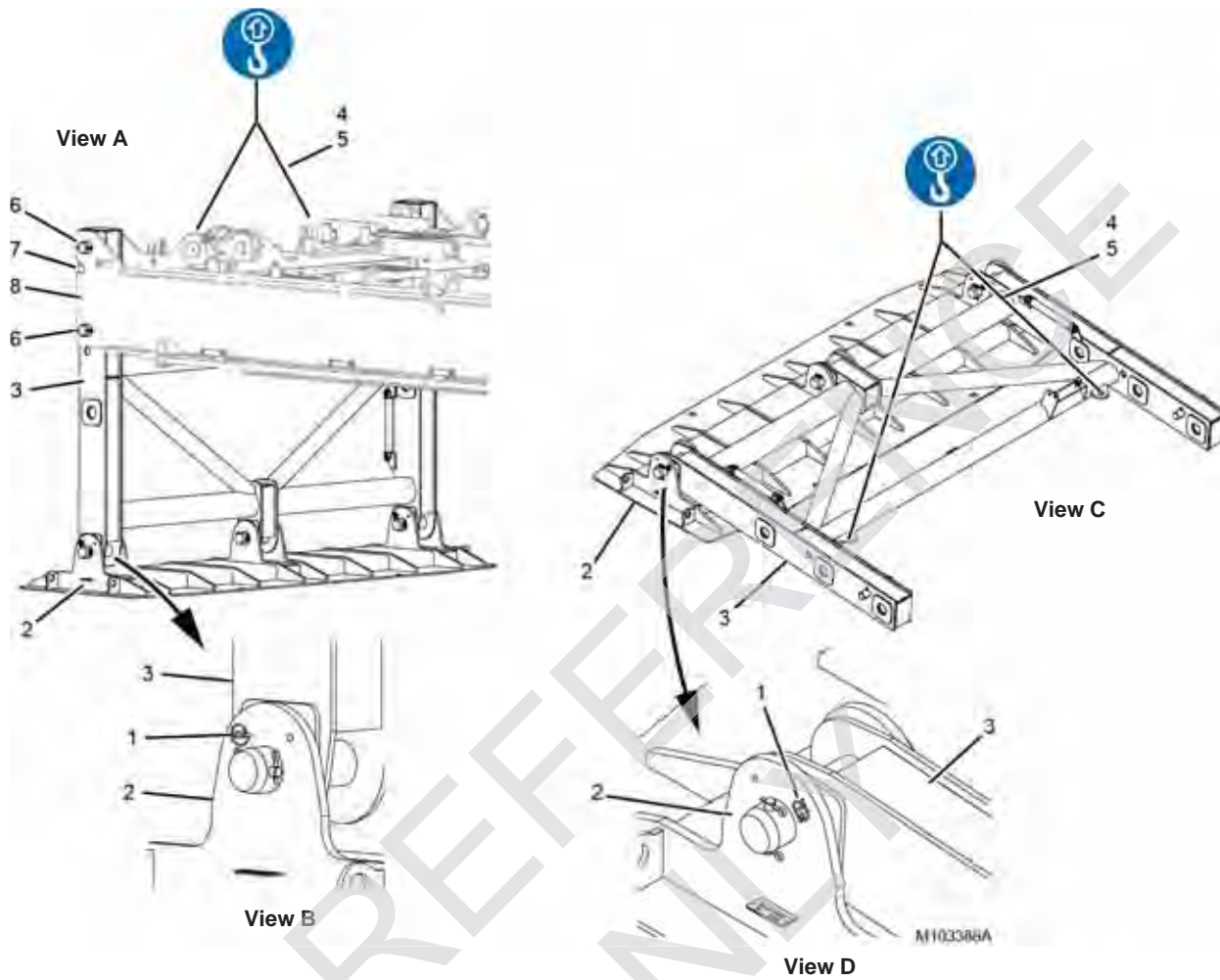

Item	Description
1	Pin with Quick-Release Pins (2)
2	Pad
3	Auxiliary Frame
4	Shackle (2): 20,5 t (23 USt)
5	Lifting Sling (2): 2,8m (9 ft) Long
6	Pin with Retaining Pins and Cotter Pins (4)
7	Alignment Pin (2)
8	VPC-MAX Beam

Figure 4-77

Remove Auxiliary Frame Assembly

See [Figure 4-77](#) for the following procedure.

1. Attach the shackles (4, View A) and lifting slings (5) to the lugs on the auxiliary frame (3) and to the hook of the assist crane.
2. Tighten the lifting slings and remove the pins (6, View A) to disconnect the auxiliary frame (3) from the VPC-MAX beam (8).
3. Lift the auxiliary frame assembly away from the end of the VPC-MAX beam (8).
4. Place the auxiliary frame assembly on a trailer or in a safe location for storage on the job site.
5. Remove the pins (1, View B) to allow the pad (2) to rotate to the shipping position during the next step.
6. Lower the auxiliary frame (3) to horizontal as shown in View C.
7. Install the pins (1, View D) to connect the pad (2) to the shipping position.
8. Install the pins (6, View A) in the VPC-MAX beam (8).
9. Disconnect the shackles and lifting slings from the auxiliary frame.

On current production units, the dust caps from the VPC-MAX Beam are stored here.

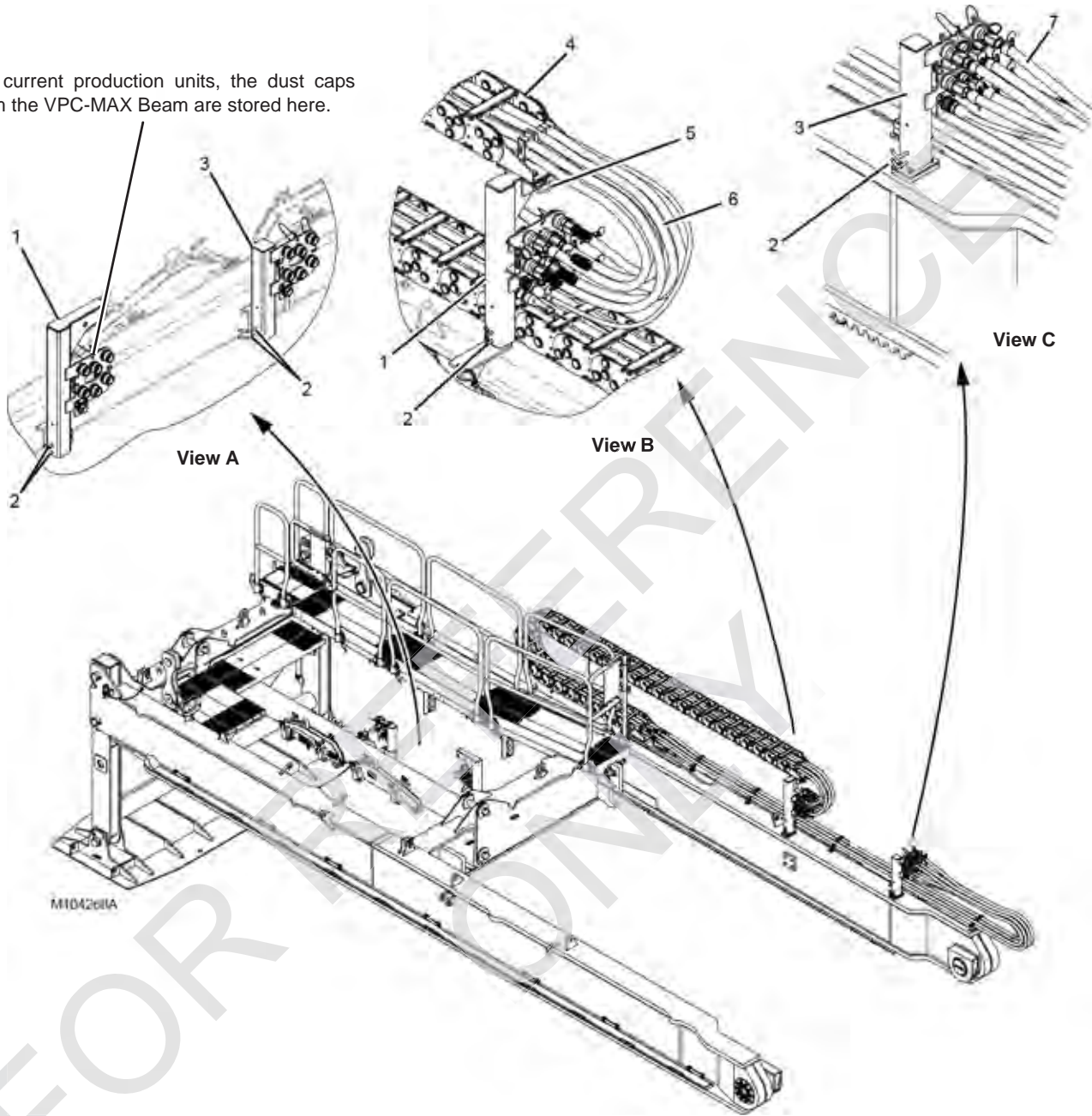

Item	Description
1	Hose/Cable Storage Bracket (energy chain) 15 kg (33 lb)
2	Hitch pin with Hair-Pin Cotter (4)
3	Hose/Cable Storage Bracket (VPC-MAX) 11 kg (24 lb)
4	Energy Chain
5	Hitch pin with Hair-Pin Cotter (2)
6	Hydraulic Hoses and Electric Cable (energy chain)
7	Hydraulic Hoses and Electric Cable (VPC-MAX)

Figure 4-78

Install Hose/Cable Storage Brackets

On current production cranes, Manitowoc provides the hose/cable storage brackets shown in [Figure 4-78](#). Install the hose/cable storage brackets, as follows:

1. Remove the hitch pins (2, View A).
2. Move the hose/cable storage bracket (1, View A) from the stored position to the shipping position (View B) and install the hitch pins (2).
3. Move the hose/cable storage bracket (3, View A) from the stored position to the shipping position (View C) and install the hitch pins (2).
4. Thoroughly clean and lubricate the couplers and receptacle on both hose/cable storage brackets.

FOR REFERENCE ONLY

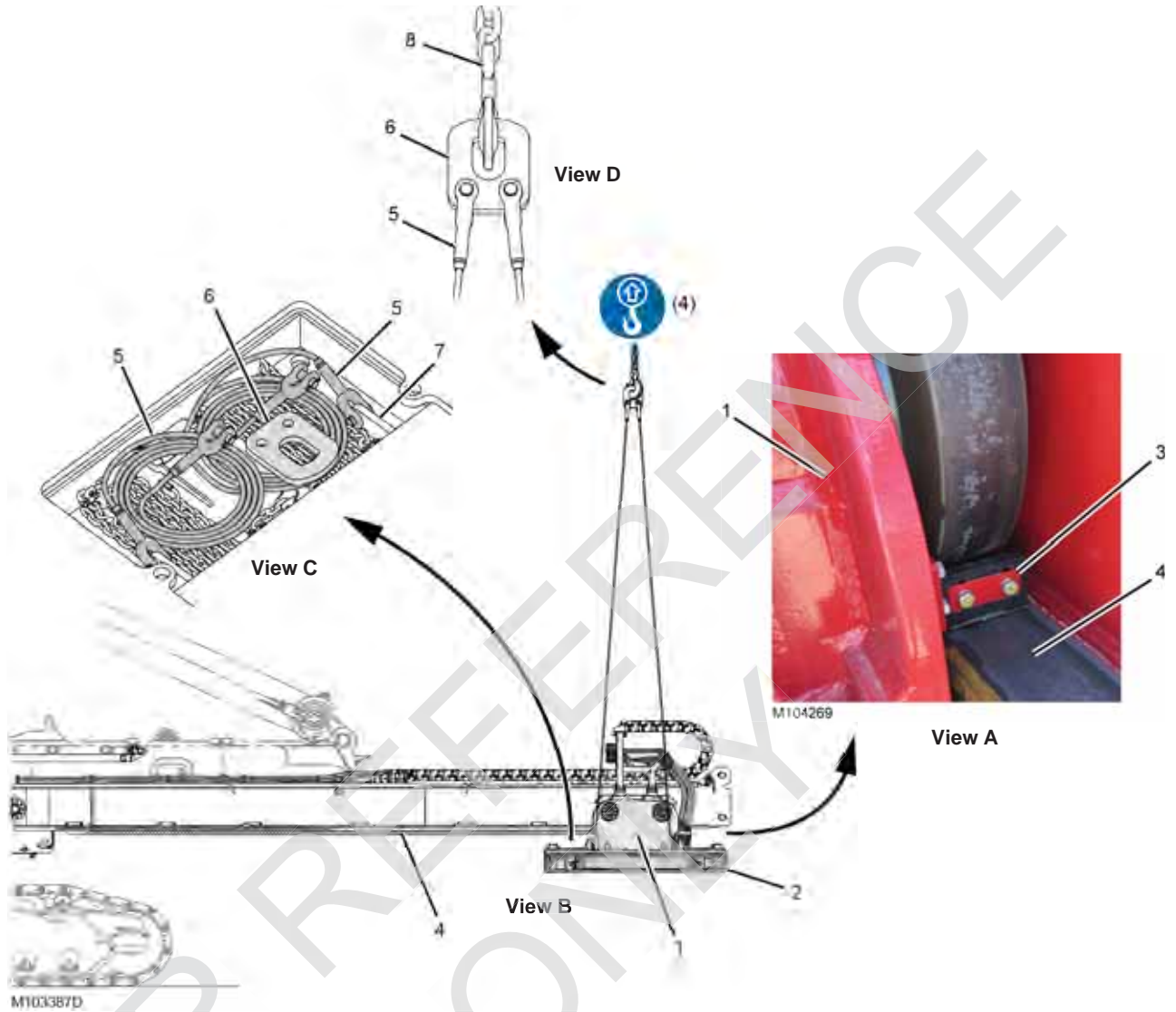

Item	Description
1	VPC-MAX Trolley
2	Counterweight Tray
3	Scraper (2)
4	VPC-MAX Beam
5	Lifting Pendant (4)
6	Lifting Plate (2)
7	Lifting Lug (4)
8	Lifting Sling (4) (owner furnished)

Figure 4-79

Position VPC-MAX Trolley at End of Beam

Using the remote control, travel the VPC-MAX trolley (1, View B) and counterweight tray (2) rearward until the scrapers (3, View A) are 25 to 51 mm (1 to 2 in) from contacting the stop blocks on the end of the VPC-MAX beam.

Attach Lifting Slings to Counterweight Tray

NOTE Manitowoc provides two lifting pendants (5, View C), a lifting plate (6), and two lifting lugs (7) on each side of the counterweight tray.

1. Attach four lifting pendants (5, View D) to the lifting slings (8) from the assist crane with the lifting plates (6).
2. Attach the other end of the lifting pendants (5, View C) to the lifting lugs (7) in the counterweight tray (2).
3. Hoist with the lifting slings until the lifting slings just start to tighten. DO NOT lift the trolley and tray at this time.

FOR REFERENCE ONLY

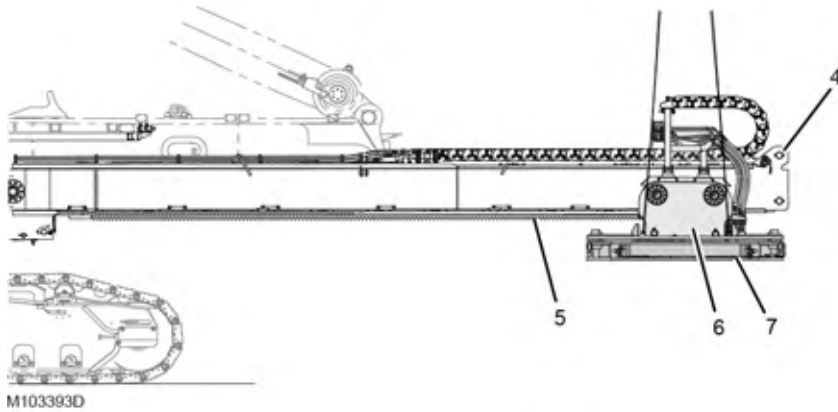

Item	Description
1	Trolley Installation Guide (2)
2	Hair-Pin Cotter (4)
3	Stop Block (2)
4	VPC-MAX Beam
5	Trolley Rail (2)
6	VPC-MAX Trolley
7	Counterweight Tray

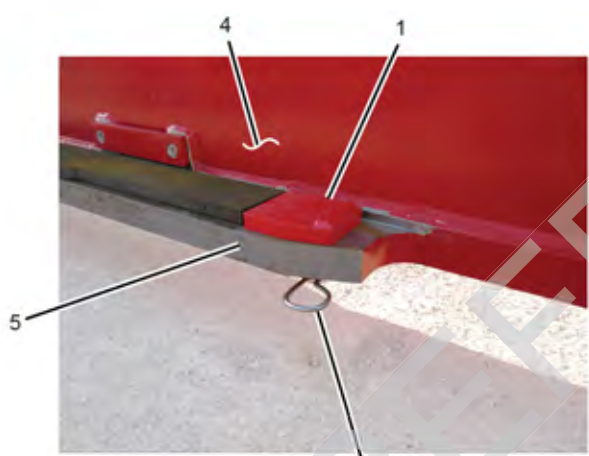

View A — WORKING

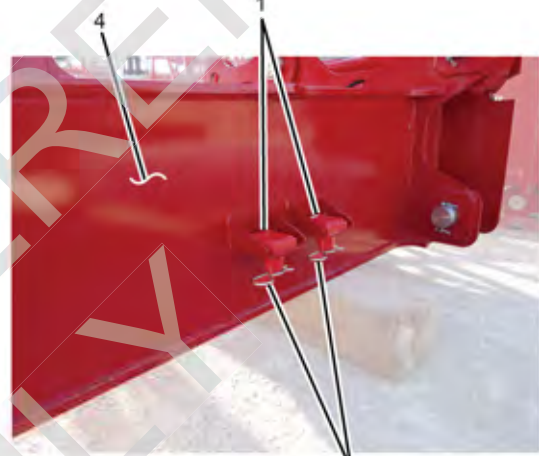

View B — STORED

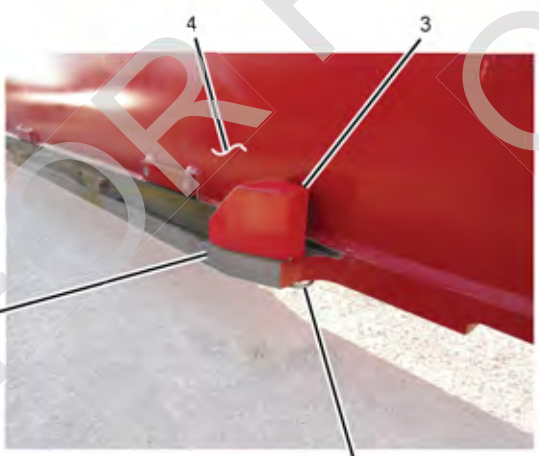

View C — WORKING

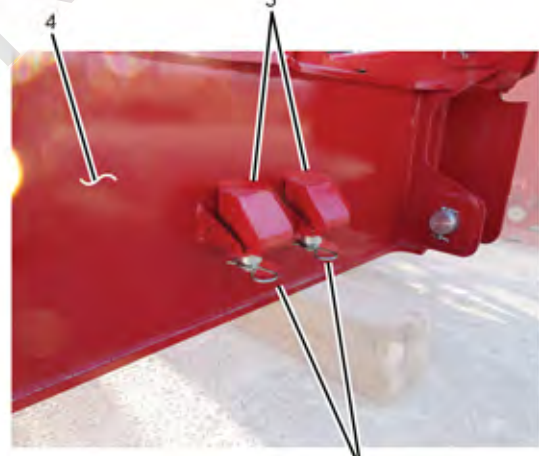

View D — STORED

Figure 4-80

Install Trolley Installation Guides

See [Figure 4-80](#) for the following procedure.



WARNING

Falling Load Hazard!

To prevent the VPC-MAX trolley from rolling off the trolley rails, do not remove the stop blocks from the ends of the trolley rails until the lifting pendants and assist crane are connected to counterweight tray (see "[Attach Lifting Slings to Counterweight Tray](#)" on page 4-141).

1. Remove the trolley installation guides (1, View B) from the stored position on the rear of the VPC-MAX beam (4).
2. Remove the stop blocks (3, View C) from the working position on the trolley rails (5).
3. Install the trolley installation guides (1, View A) in the working position on the trolley rails (5).
4. Secure the trolley installation guides with the hair-pin cotters (2).
5. Install the stop blocks (3, View D) in the stored position on the rear of the VPC-MAX beam (4).
6. Secure the stop blocks with the hair-pin cotters (2).

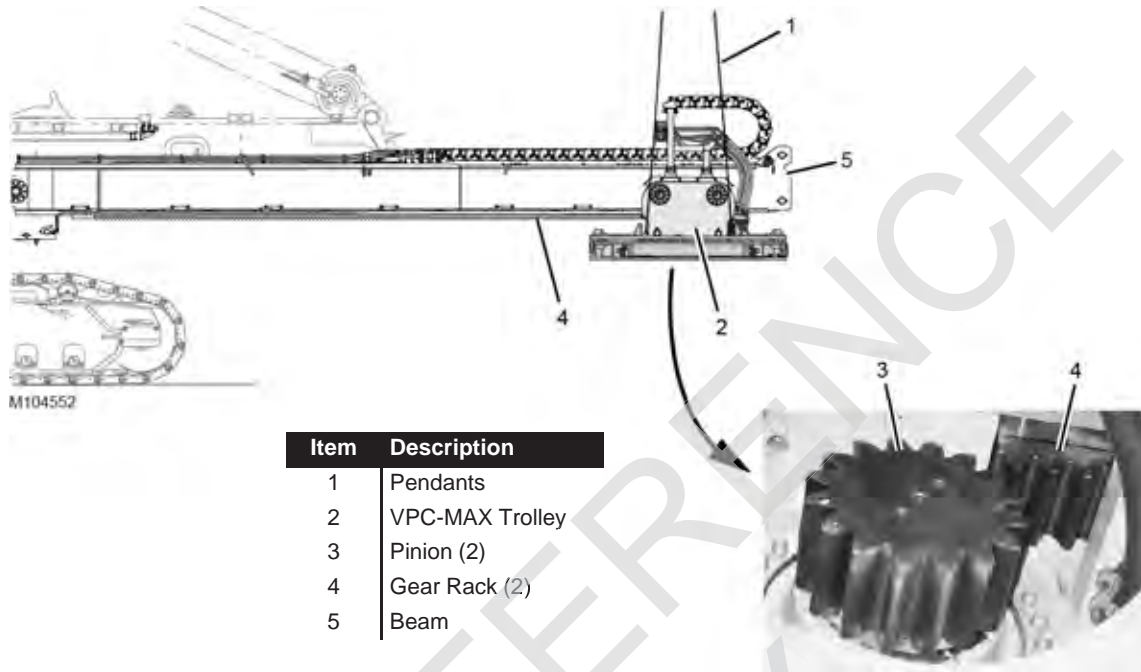

Figure 4-81

Disengage Trolley Drive Pinions from Gear Racks

See [Figure 4-81](#) for the following procedure.

1. Make sure the trolley rollers are bearing the weight of the trolley and counterweight tray on the rails. The lifting pendants (1) should be tight but not lifting the trolley and tray.
2. While following with the assist crane, use the remote control to drive the VPC-MAX trolley (2) rearward until

the drive pinions (3) are disengaged from the gear rack (4) on both sides of the VPC-MAX beam (5).

The drive pinions can be viewed from under the VPC-MAX trolley by removing the access guard from both sides of the VPC-MAX trolley.

3. Once the pinions are disengaged from the gear rack, reinstall the access guard (if removed) on both sides of the VPC-MAX trolley.

FOR REFERENCE ONLY

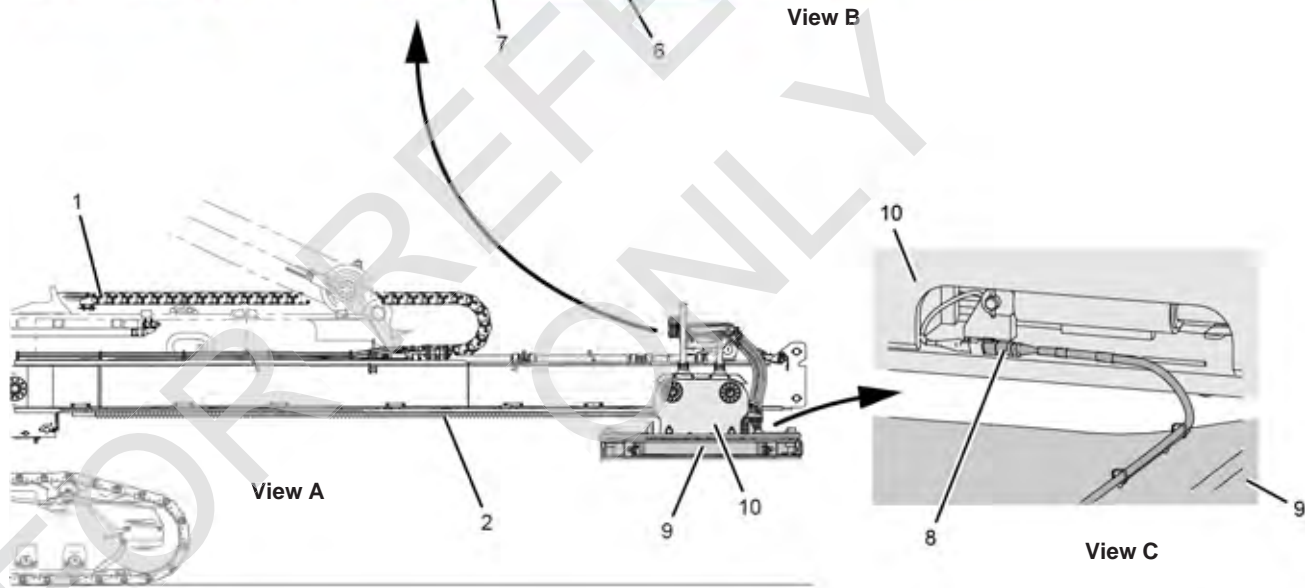
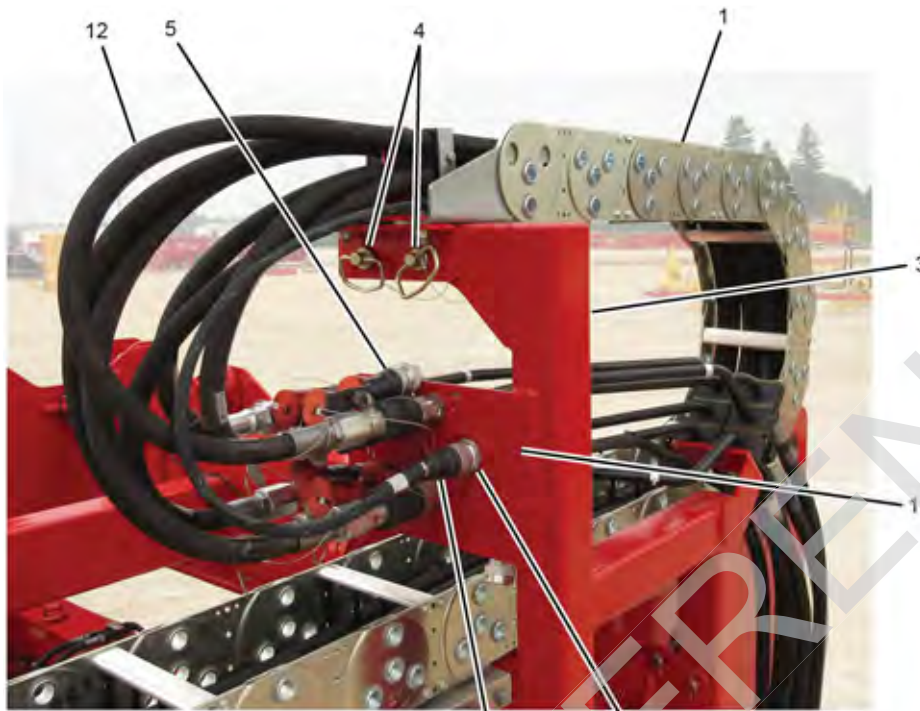

Item	Description	Item	Description
1	Energy Chain	7	Electric Cable
2	VPC-MAX Beam	8	Electric Cable
3	Energy Chain Frame	9	Counterweight Tray
4	Hitch Pin with Hair-Pin Cotter (2)	10	VPC-MAX Trolley
5	Shorting Plug with Dust Cap	11	Bulkhead
6	Receptacle	12	Hydraulic Hose (6)

Figure 4-82

Disconnect VPC-MAX Trolley Hydraulic Hoses

See [Figure 4-82](#), View B for the following procedure.

1. Disconnect the hydraulic hoses (12) from the hydraulic nipples on the bulkhead (11).
2. Thoroughly clean and lubricate the hydraulic nipples and the couplers.
3. Thoroughly clean and connect the dust caps to the hydraulic nipples on the bulkhead (11).

On current production units, the dust caps are stored on the bracket (1, View A, [Figure 4-78 on page 4-138](#))

4. For past production units without the hose/cable storage bracket shown in View B, [Figure 4-78 on page 4-138](#), connect dust caps to the ends of the hydraulic hoses (12).

Disconnect VPC-MAX Trolley Electric Cables

See [Figure 4-82](#), View C for the following steps.

1. Disconnect the electric cable (8) from the counterweight tray (9) at the electric cable in the right rear corner of the VPC-MAX trolley (10).
2. Thoroughly clean the electric cable ends and the dust caps.
3. Connect the dust caps to the electric cable ends.

See [Figure 4-82](#), View B for the remaining steps.

4. Disconnect the electric cable (7) from the receptacle (6) on the bulkhead (11).
5. Remove the dust cap from the shorting plug (5).
6. Thoroughly clean the electric cable end, the receptacle, the shorting plug, and the dust caps.
7. Connect the shorting plug (5) to the receptacle (6).
8. For past production units without the hose/cable storage bracket shown in View B, [Figure 4-78 on page 4-138](#), connect a dust cap to the end of the electric cable (7).

Disconnect VPC-MAX Energy Chain from VPC-MAX Trolley

See [Figure 4-82](#) for the following procedure.

1. Remove the hitch pins (4, View B) securing the energy chain (1) to the energy chain frame (3).
2. Lift the energy chain (1) clear of the energy chain frame (3).
3. Refer to View B, [Figure 4-26 on page 4-40](#) and remove the hitch pins (3a). Tilt the energy chain frame (3) outward.
4. For past production units without the hose/cable storage bracket shown in View B, [Figure 4-78 on page 4-138](#), proceed as follows:
 - a. Install the hitch pins (4, View B) in the end of the energy chain (1).
 - b. Roll the energy chain (1) forward as far as it will go.
 - c. Securely fasten the energy chain to the VPC-MAX beam with user furnished cargo straps.
5. For current production units with the hose/cable storage bracket shown in View B, [Figure 4-78 on page 4-138](#), proceed as follows:
 - a. Slowly roll the energy chain (1) forward until the holes in the end of the energy chain are aligned with the holes in end of the hose/cable storage bracket shown in View B, [Figure 4-78 on page 4-138](#).
 - b. Install the hitch pins to fasten the energy chain to hose/cable storage bracket.
 - c. Connect the hydraulic hoses and the electric cable to the storage couplers and receptacle on the hose/cable storage bracket shown in View B, [Figure 4-78 on page 4-138](#).
6. Refer to View B, [Figure 4-26 on page 4-40](#) and tilt the energy chain frame (3) inward to the working position. Install the hitch pins (3a).

Item	Description
1	Trolley Rail (2)
2	Gear Rack (2)
3	Counterweight Tray
4	VPC-MAX Trolley
5	VPC-MAX Beam
6	Trolley Rollers (4)
7	Lifting Pendants (4)
8	Lifting Plate (2)
9	Lifting Sling (4) (owner furnished)

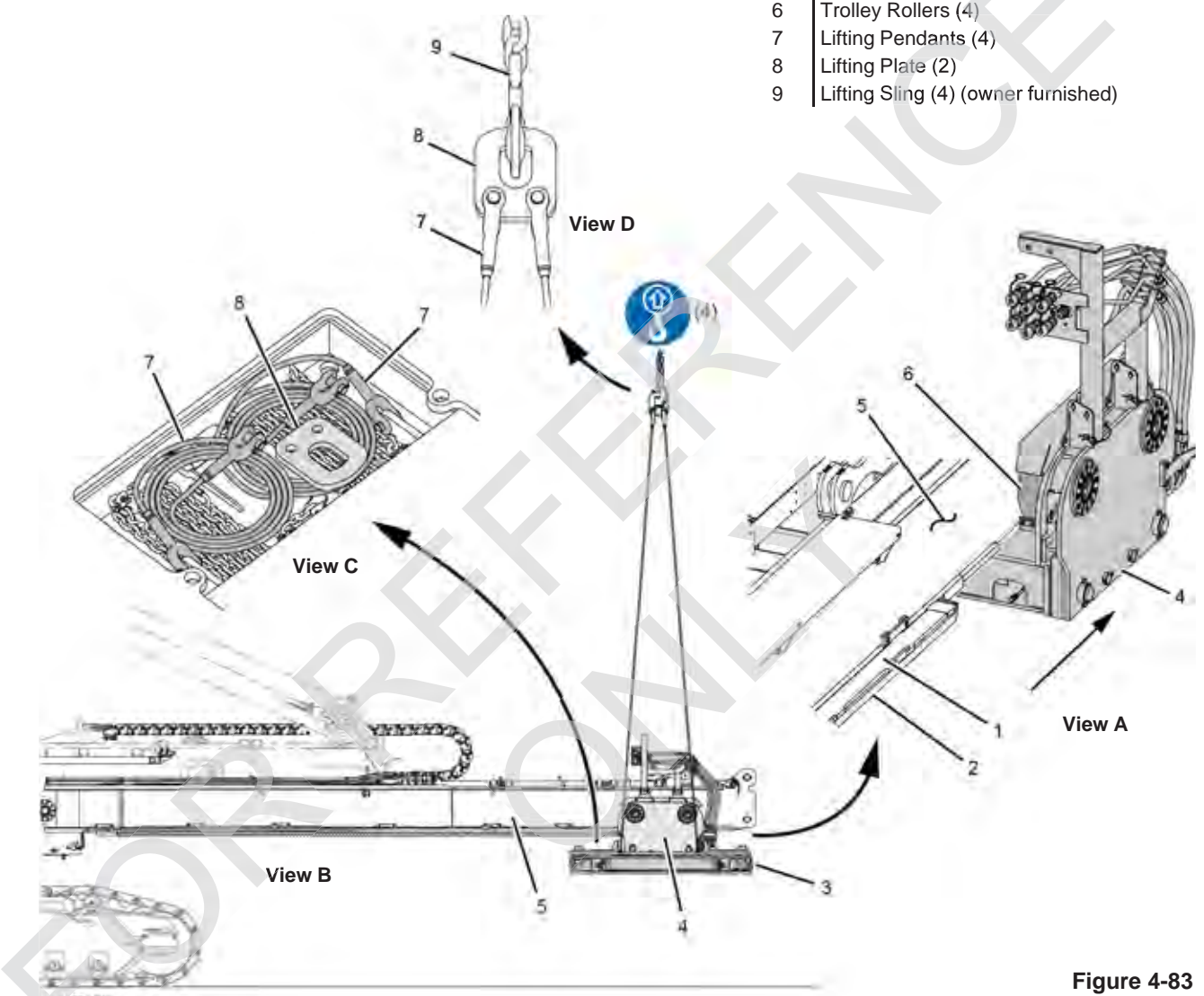

Figure 4-83

Remove VPC-MAX Trolley and Counterweight Tray

See [Figure 4-83](#) for the following procedure.

1. Lift the VPC-MAX trolley and counterweight tray off the VPC-MAX beam.

It will be necessary to lift the counterweight tray and trolley high enough so the rollers clear the stops on the installation guides.

2. Place the counterweight tray and VPC-MAX trolley on blocking at ground level.

3. Lower the lifting pendants (7, View D) until they are slack.
4. Disconnect the lifting pendants (7, View D) and the lifting plates (8) from the assist crane slings (9).
5. Coil the lifting pendants (7, View C) into the storage pockets in the tray.
6. Place the lifting plates (8, View C) into the storage pockets in the tray.

FOR REFERENCE ONLY

Item	Description
1	VPC-MAX Trolley
2	Retaining Pin with Cotter Pins (4)
3	Collar (4)
4	Pin (4)
5	Mounting Frame (2)
6	Counterweight Tray

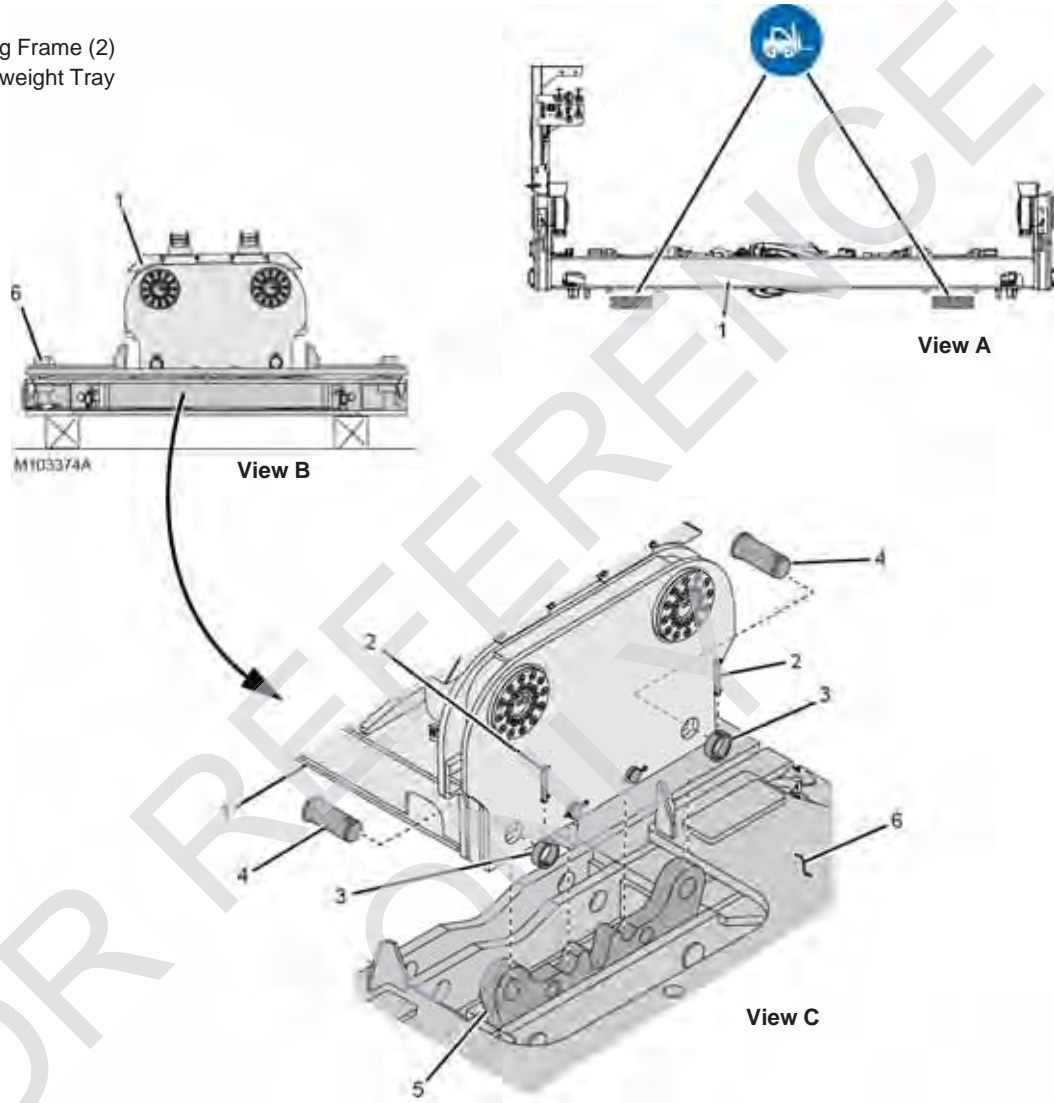
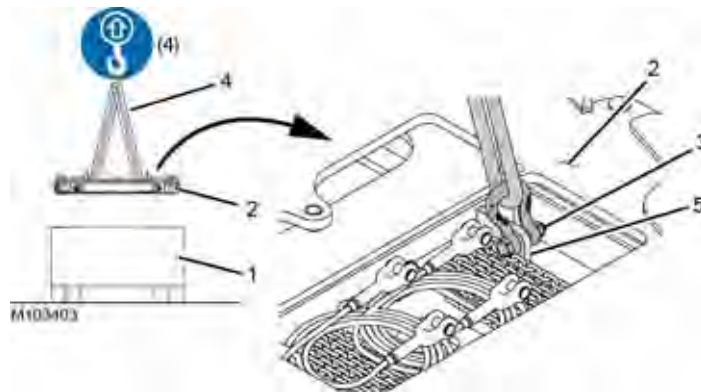

Figure 4-84



Item	Description
1	Trailer
2	Counterweight Tray
3	Shackle (4): 20,5 t (23 USt)
4	Lifting Slings (4): 2,8m (9 ft) long
5	Lifting Lug (4)

Figure 4-85

Remove VPC-MAX Trolley from Counterweight Tray

See [Figure 4-84](#) for the following procedure.

1. Position the forks from a forklift under the VPC-MAX trolley (1, View A) at the locations shown.
2. Remove the retaining pins (2, View C), the collars (3), and the pins (4) from the VPC-MAX trolley (1).
3. Slowly lift the VPC-MAX trolley (1, View C) off the mounting frames (5) on the counterweight tray (6).
4. Reinstall the pins (4, View C), the collars (3), and the retaining pins (2) in the VPC-MAX trolley (1).

5. Lift the VPC-MAX trolley onto a trailer and secure it for shipping or store it in a safe location on the job site.
6. Remove the forklift.

Install Counterweight Tray on Trailer

See [Figure 4-85](#) for the following procedure.

1. Connect the shackles (3) and lifting slings (4) to the lifting lugs (5) on the counterweight tray and to the hook of the assist crane.
2. Lift the counterweight tray onto a trailer and secure it for shipping or store it in a safe location on the job site.
3. Disconnect the shackles and lifting slings from the counterweight tray.

Item	Description
1	Shackle (2): 20,5 t (23 US t)
2	Lifting Sling (2): 2,8m (9 ft) long
3	VPC-MAX Beam
4	Hook (2)
5	Pin (2)
6	13 mm (1/2 in)
7	VPC Trolley
8	Stop Block (2)
9	Blocking: 305 mm (12 in) high

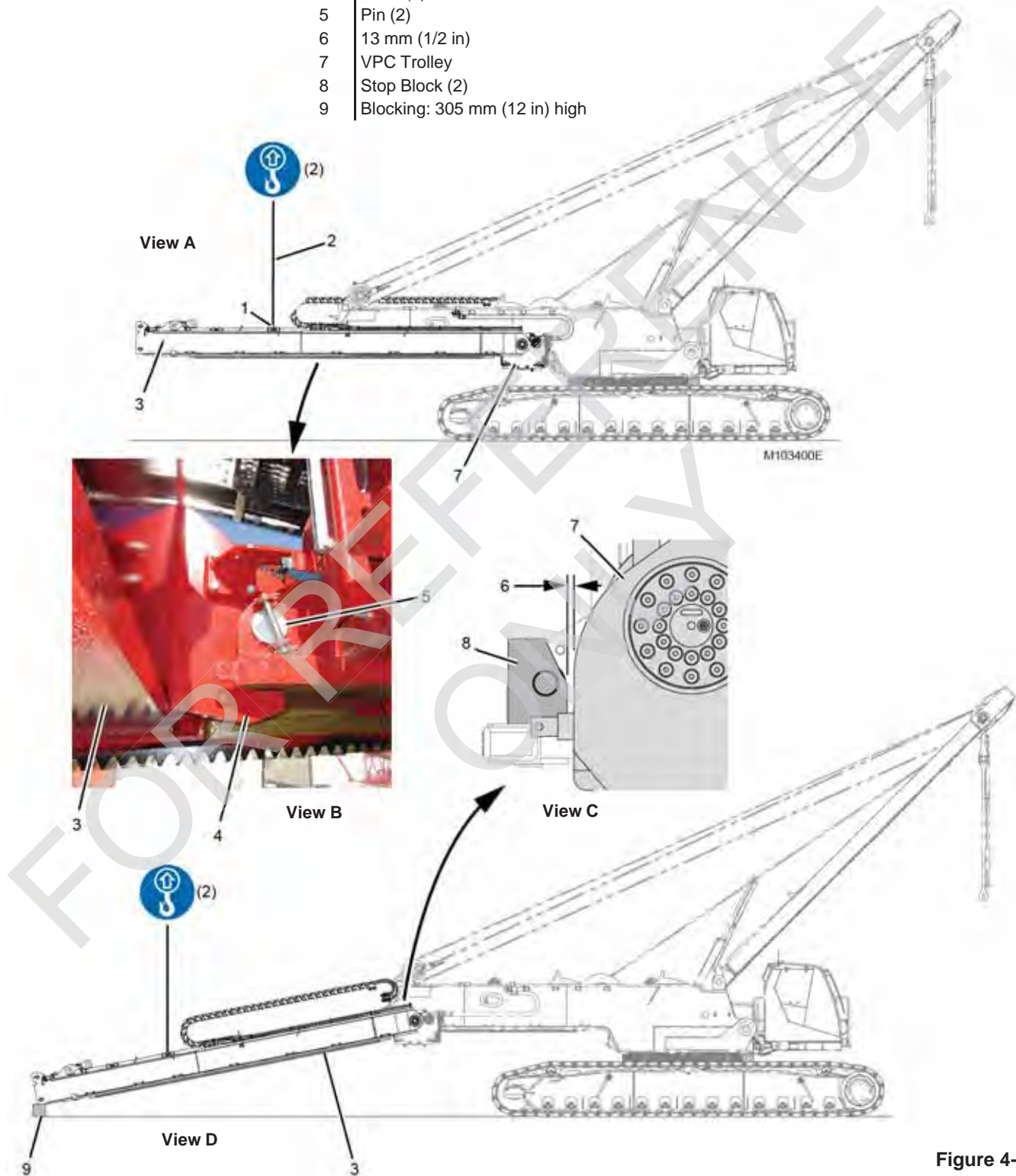

Figure 4-86

Unhook VPC-MAX Beam from Rotating Bed

See [Figure 4-86](#) for the following steps.

1. Connect two shackles (1, View A) and two lifting slings (2) to the proper rear lifting lugs on the VPC-MAX beam (3).

See Views B and C, [Figure 4-12 on page 4-16](#) for the location of the lifting lugs.

2. Lift the rear of the VPC-MAX beam (3, View A) to horizontal with the assist crane. The hooks (4, View B) should now be lifted off the pins (5).

3. Follow with the assist crane during [step 4](#).
4. Using the switch on the remote control, travel the VPC trolley (7, View A) rearward until the distance (6, View C) between the VPC trolley (7) and the stop block (8) on both sides of the rotating bed is 13 mm (1/2 in).
5. Lower the rear of the VPC-MAX beam (3, View D) onto 305 mm (12 in) high blocking (9) — relative to level ground at the crawlers.

FOR REFERENCE ONLY

Item	Description
1	Shorting Plug with Dust Cap
2	Electric Cable (WVT1E)
3	VPC Trolley
4	Electric Cable with Dust Cap (WVB3)
5	VPC-MAX Beam (left side)
6	Hydraulic Nipple
7	Bulkhead
8	Coupler (6)
9	Hydraulic Hose (6)

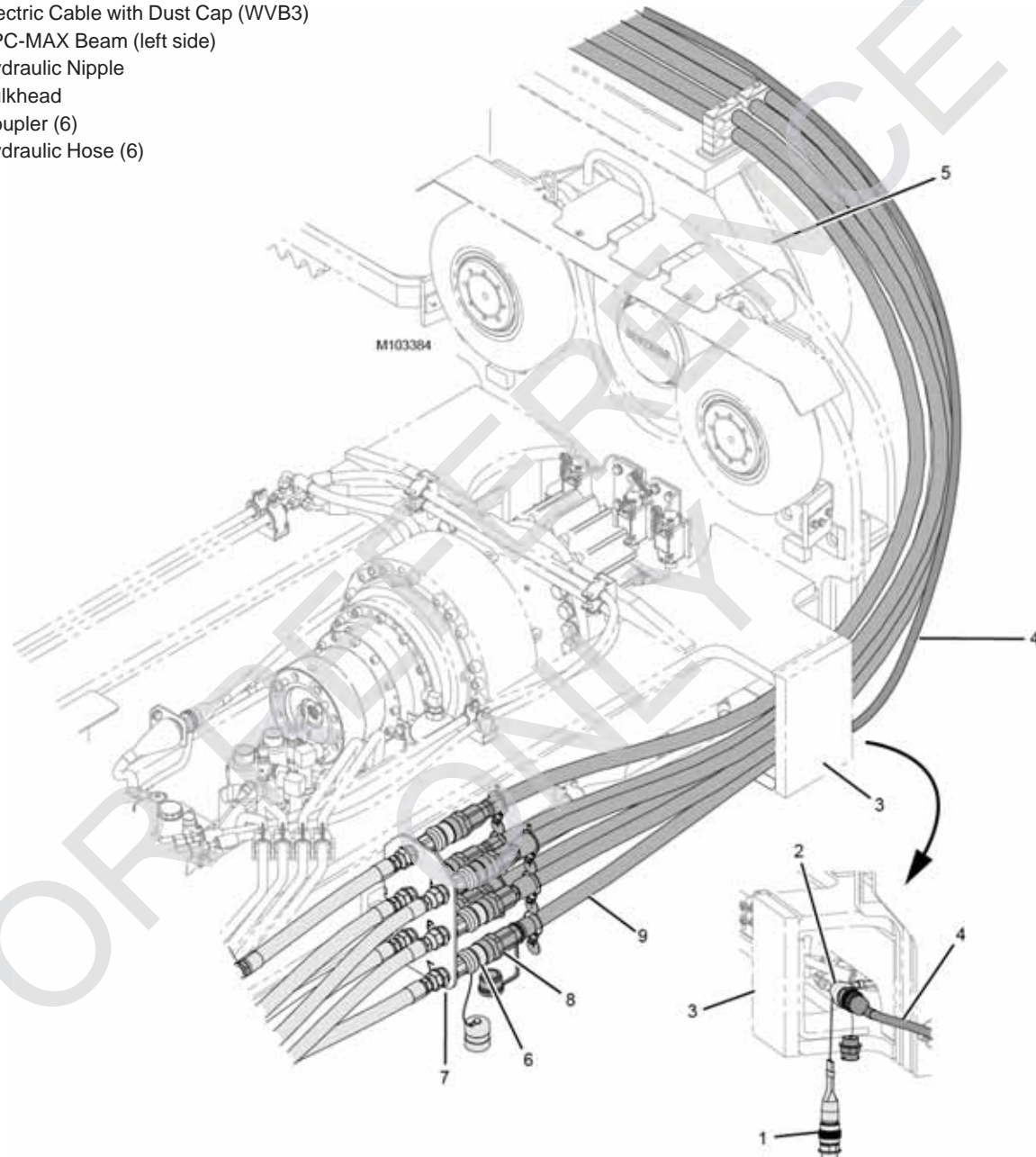

Figure 4-87

NOTE Current production cranes are equipped with the hose/cable storage brackets shown in [Figure 4-78 on page 4-138](#).

If not already done, remove the hose/cable storage bracket (3, View A, [Figure 4-78 on page 4-138](#)) from storage and install it on the beam as shown in View C.

Disconnect VPC-MAX Beam-to-VPC Trolley Electric Cable

1. Disconnect the electric cable (4) from the electric cable (2).
2. Thoroughly clean the electric cable ends.
3. Disconnect the dust cap from the shorting plug (1) and connect the shorting plug (1) to the electric cable (2).
4. If equipped, thoroughly clean the dust cap and connect it to the electric cable (4).
5. On current production cranes, connect the electric cable (4) to the receptacle on the hose/cable storage bracket (3, View C, [Figure 4-78 on page 4-138](#)).

Disconnect VPC-MAX Beam-to-VPC Trolley Hydraulic Hoses

1. Disconnect the hydraulic hoses (9) from the hydraulic nipples (6) on the bulkhead (7).
2. Thoroughly clean and lubricate the hydraulic nipples and couplers.
3. Thoroughly clean and lubricate the dust caps and connect them to the nipples (6).
4. If equipped, thoroughly clean and lubricate the dust caps and connect them to the couplers (8) on the hydraulic hoses (9).
5. On current production cranes, connect the hydraulic hoses (9) to the couplers on the hose/cable storage bracket (3, View C, [Figure 4-78 on page 4-138](#)).
6. On past production cranes without the hose/cable storage bracket, securely attach the hydraulic hoses and electric cable to the VPC-MAX beam with a user furnished cargo strap.

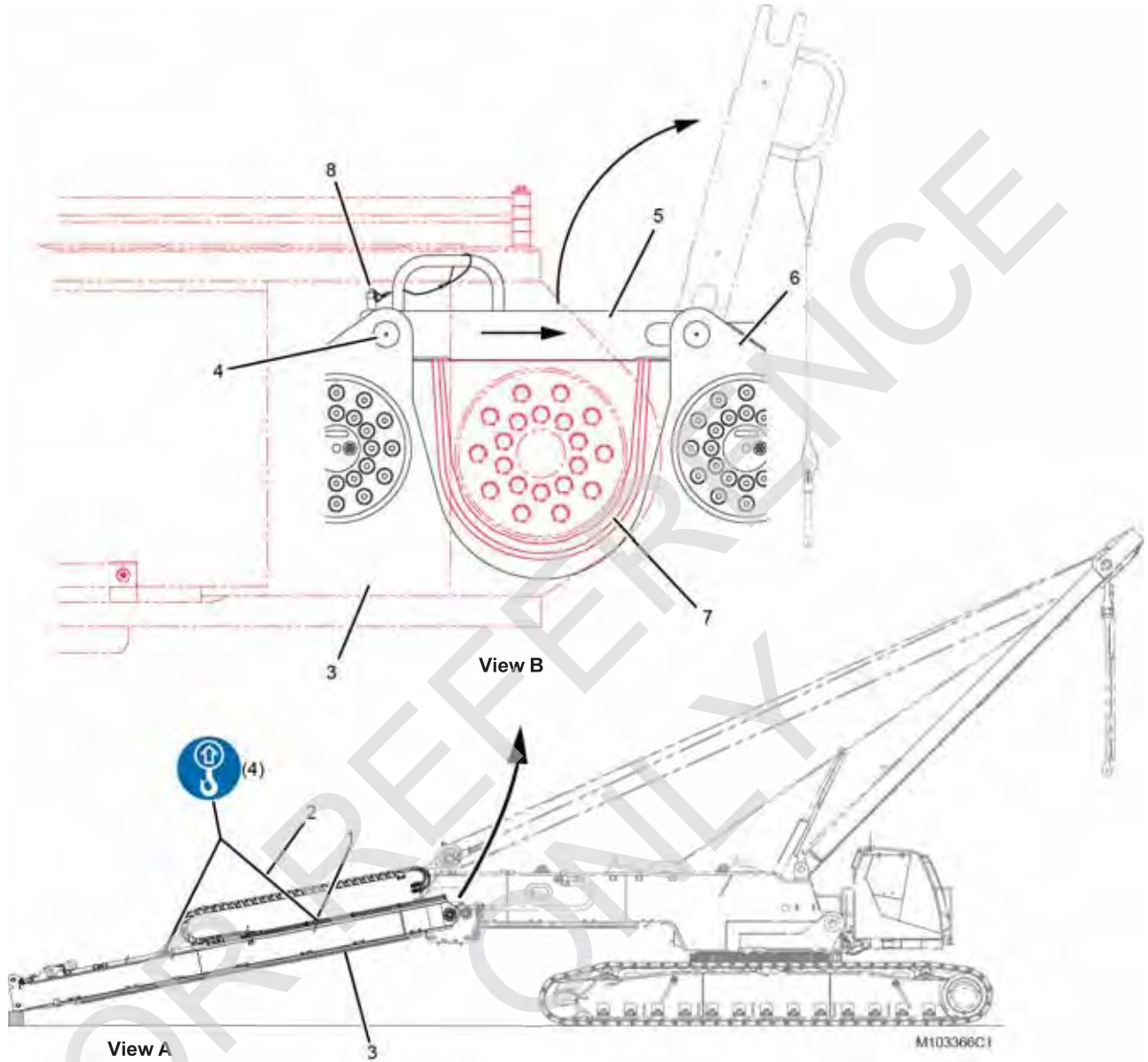

Item	Description
1	Shackle (4): 20,5 t (23 USt)
2	Lifting Sling (4): 2,8m (9 ft) long
3	VPC-MAX Beam
4	Pin (2)
5	Latch (2)
6	VPC Trolley
7	Spherical Bearing Carrier (2)
8	Quick-Release Pin (2)

Figure 4-88

Disconnect VPC-MAX Beam from VPC Trolley

See [Figure 4-88](#) for the following procedure.

1. Connect two additional shackles (1, View A) and two lifting slings (2) to the front lifting lugs on the VPC-MAX beam (3) and to the hook of the assist crane.

See Views B and C, [Figure 4-12 on page 4-16](#) for the location of the lifting lugs.

2. Remove the quick-release pins (8, View B), slide the latches (5) forward off the pins (4), and rotate the latches up and out of the way.

3. Lift the VPC-MAX beam (3, View C) straight up so the spherical bearing carriers (7, View D) disengage the VPC trolley (6).
4. Place the VPC-MAX beam on blocking as shown in [Figure 4-90 on page 4-160](#).
5. Close the latches (5, View B) and install the quick-release pins (8).
6. Install the hinge covers (View D, [Figure 4-10 on page 4-14](#)).

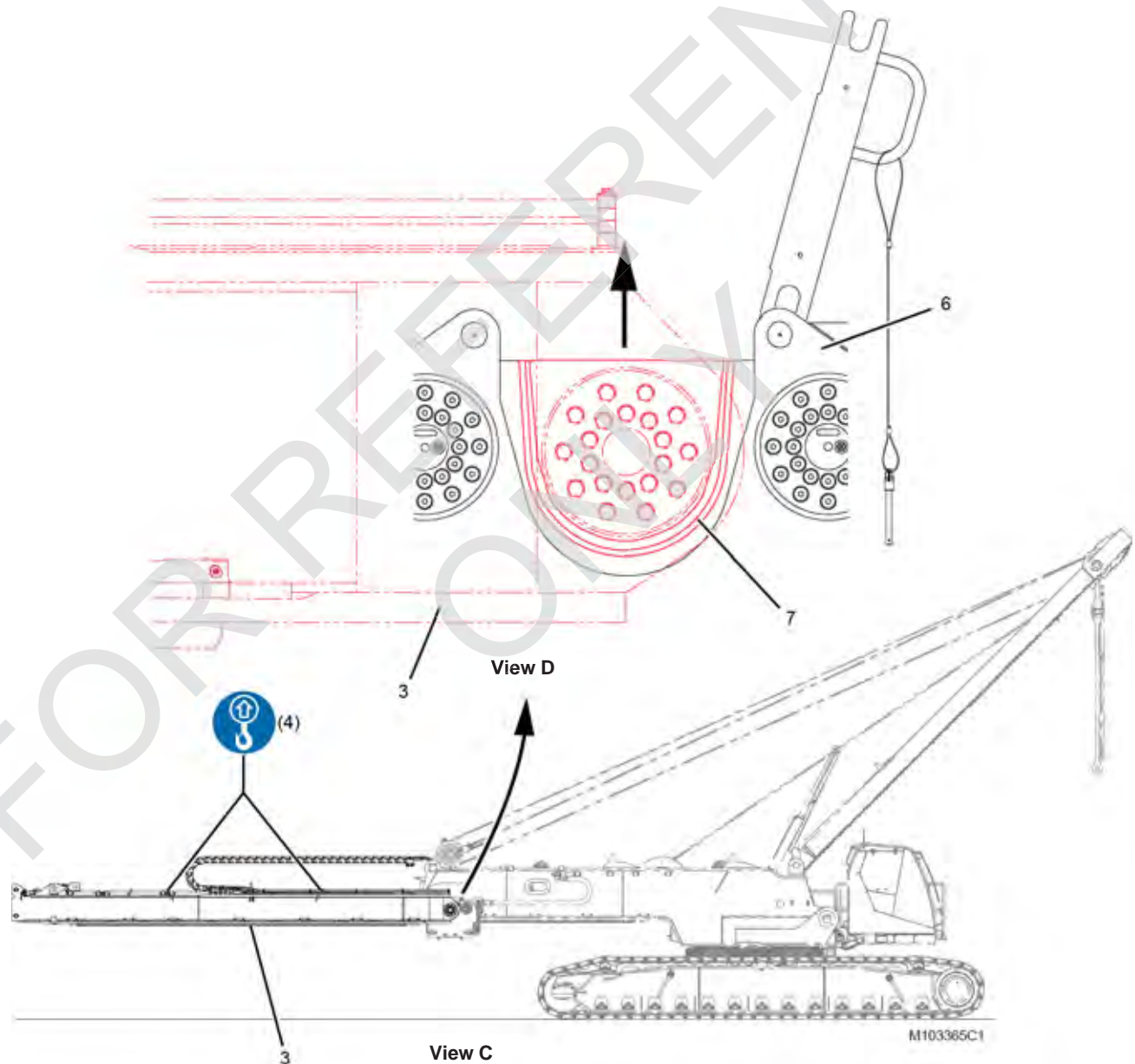

Figure 4-88 continued

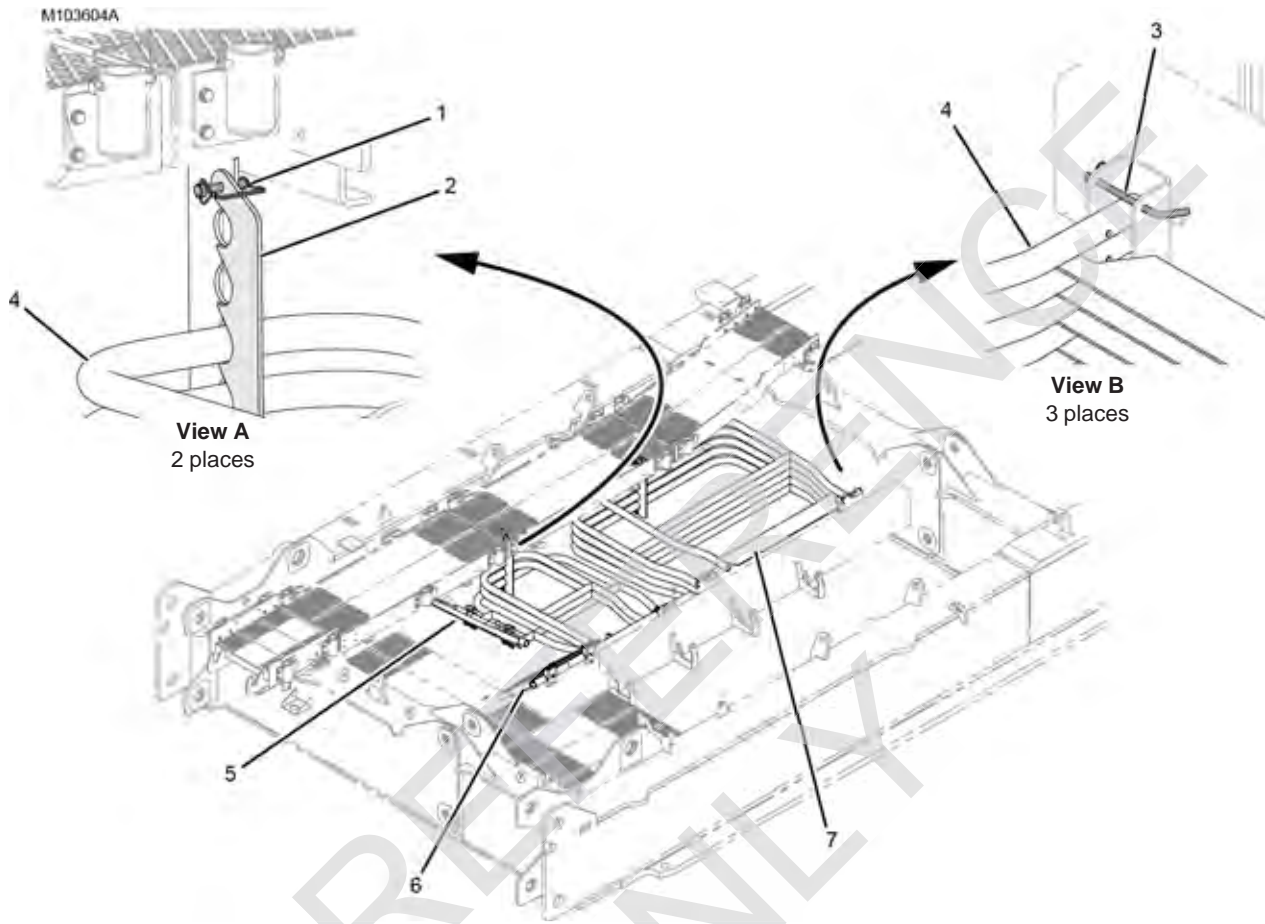

Figure 4-89

Item	Description
1	Safety Pin (2)
2	Bracket (2)
3	Hitch Pin with Hair-Pin Cotter (3)
4	Handrails
5	Handrail with Gate (2 legs)
6	Handrail with Gate (1 leg)
7	Narrow Handrail

Store Handrails in VPC-MAX Beam

See [Figure 4-89](#) for the following procedure.

1. Remove the safety pins (1, View A) and lower the brackets (2).
2. Remove the hitch pins (3).
3. Lift the handrails (4) into position in the VPC-MAX beam.
The heaviest handrail weighs 10 kg (22 lb).

- Wide handrail with gate (5) must be installed at the bottom of the stack.
 - Narrow handrail with gate (6) must be installed at the top of the stack.
 - Narrow handrail (7) must be installed at the top of the stack.
4. Close the brackets (2, View A) and reinstall the safety pins (1).
 5. Reinstall the hitch pins (3, View B).

FOR REFERENCE ONLY

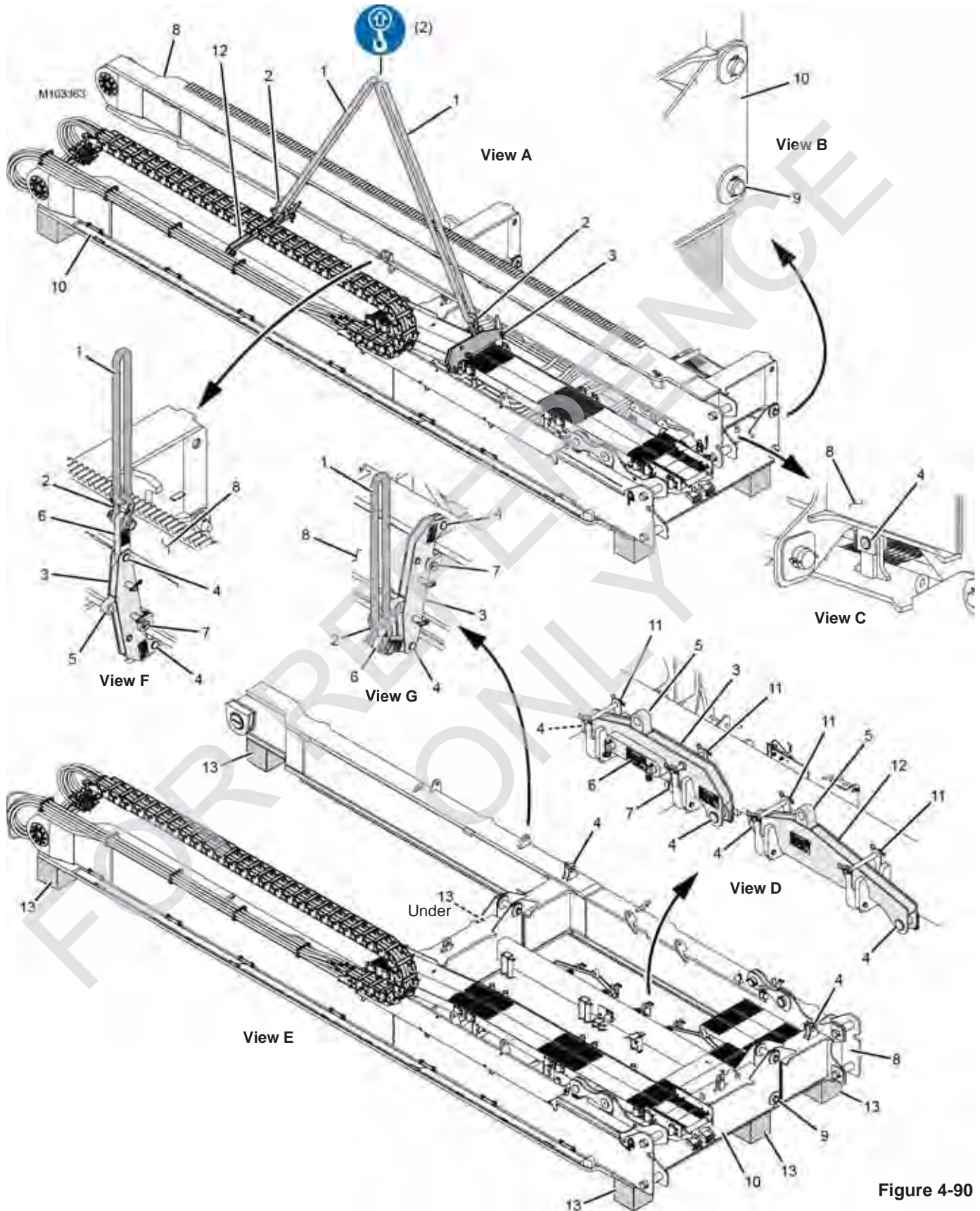

Figure 4-90

Legend for [Figure 4-13](#).

Item	Description
1	Lifting Sling (2): 2,8 m (9 ft) long
2	Shackle (2): 20,5 t (23 USt)
3	Rear Spreader Beam – 40 kg (88 lb)
4	Pin with Safety Pin (6)
5	Lifting Lug
6	Lifting Link
7	Pin with Safety Pin
8	Right-Hand Beam
9	Pin with Retaining Pin and Cotter Pins (2)
10	Left-Hand Beam
11	Pin with Hair-Pin Cotters (4)
12	Front Spreader Beam – 21 kg (46 lb)
13	Blocking (6 places)

Fold VPC-MAX Beam for Shipping

The VPC-MAX beam can be shipped in one of three ways depending on user preference:

- Folded (View A, [Figure 4-90](#))
- Un-folded with auxiliary frame assembly installed (View B, [Figure 4-91 on page 4-162](#))
- Un-folded with auxiliary frame assembly removed (View C, [Figure 4-91 on page 4-162](#))

See [Figure 4-90](#) for the following procedure.

- Unpin and remove the rear and front spreader beams (3 and 12, View D) using the existing lifting slings (1) shackles (2).
- Place the front spreader beam to side until later.
- Place the rear spreader beam (3) on the suitable work surface and prepare it as follows (see View G):
 - Disconnect the lifting sling (1) and shackle (2) from the lifting lug (5) on the spreader beam.
 - Remove the lifting link (6) from storage on the spreader beam.
- Pin the lifting link (6) to the spreader beam with pin (4).
- Remove pin (7) from storage in the spreader beam.
- Connect the lifting sling (1) and shackle (2) to the lifting link (6).
- Lift the rear spreader beam (3, View G) into position and pin it to the lifting lugs on the right-hand beam (8) with pins (4 and 7).
- To prevent tipping**, Make sure the beams are blocked as shown in View E.
- Remove two pins (4, View E) from storage in the lugs on the right-hand beam (8).
- Tighten the lifting sling (1, View G), and remove two bottom pins (9, View E) to disconnect the right-hand beam (8) from the left-hand beam (10).
- Using the assist crane, slowly lift and rotate the right-hand beam (8, View E) from the working position to the shipping position (Views A and F).
- Install the pins (4, View C, two places) to connect the right-hand beam (8) to the left-hand beam (10).
- Remove the rear spreader beam (3, View F) from the right-hand beam (8).
 - Store the lifting link (6, View D) on the rear spreader beam (3)
 - Reinstall pins (7, View F) in the lugs on the right-hand beam (8).
- Attach the existing lifting slings (1) and shackles (2) to the rear and front spreader beams (3 and 12, View A).
- Pin the rear and front spreader beams (3 and 12, View A) to the lifting lugs on the beams (8 and 10) with pins (4).
- Lift the VPC-MAX beam onto a trailer and secure it for shipping or store it in a safe location on the job site.
- Disconnect the shackles and lifting slings from the lifting lugs on the spreader beams.

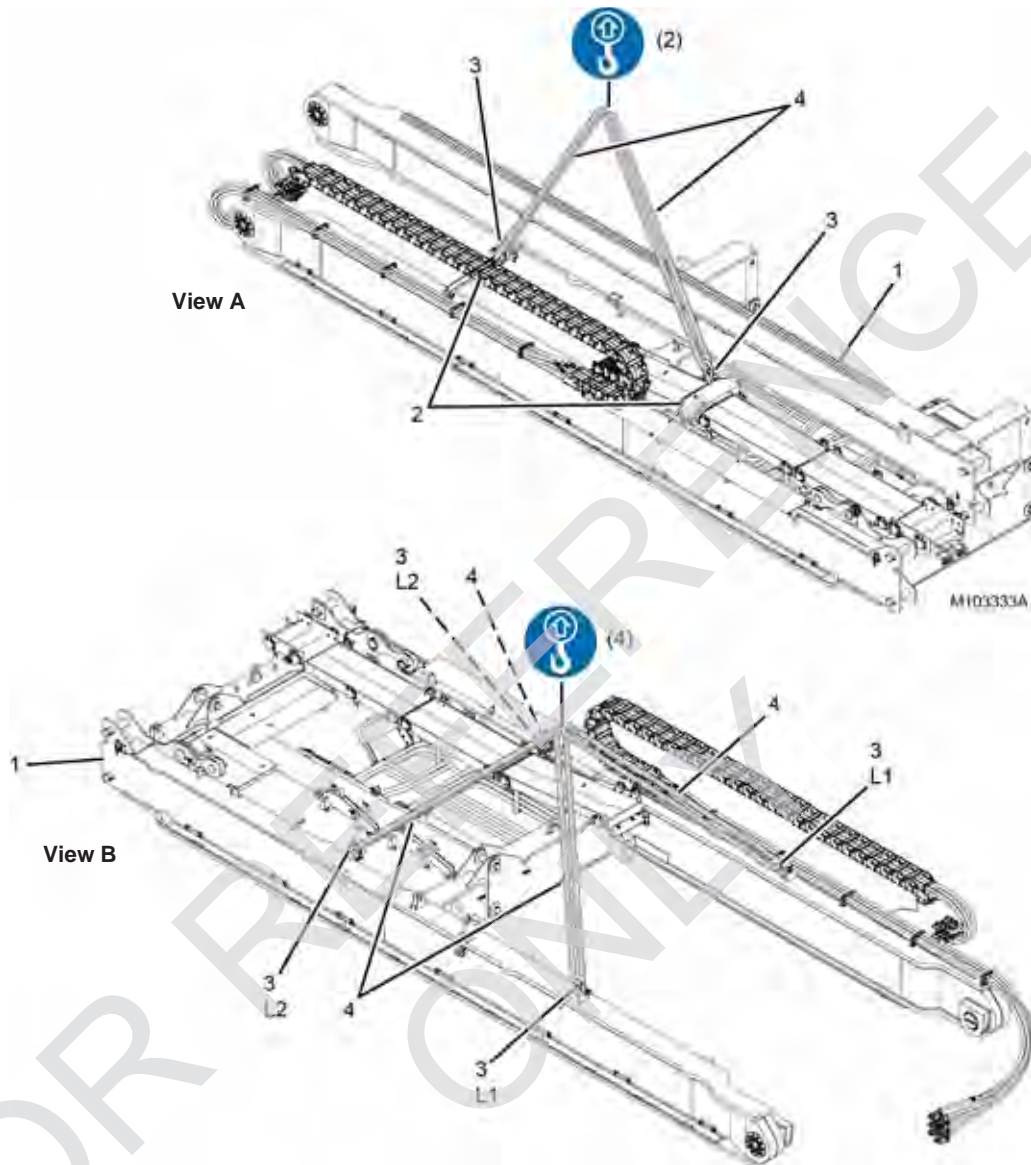

Item	Description
1	VPC-MAX Beam
2	Spreader Beam (2)
3	Shackle (2 or 4): 20,5 t (23 USt)
4	Lifting Sling (2 or 4): 2,8m (9 ft) long
L1	Front Lifting Lug (2)
L2	Mid-Rear Lifting Lug (2)

Figure 4-91

Install VPC-MAX Beam on a Trailer

The VPC-MAX beam (1) can be shipped in one of two ways as shown in [Figure 4-12](#):

- Folded (View A) (see [page 4-161](#) for procedure)
- Un-folded (View B)

See [Figure 4-91](#) for the following procedure.

1. If the beam is folded, see [page 4-161](#) for the procedure.
2. If the beam is un-folded, proceed as follows:
 - a. Connect four shackles (3, View B) and four lifting slings (4) to the lifting lugs (L1 and L2) on the VPC-MAX beam.
 - b. Connect the other end of the lifting slings to the hook of the assist crane.
 - c. Lift the VPC-MAX beam onto a trailer and secure it for shipping or store it in a safe location on the job site.
 - d. Disconnect the shackles and lifting slings from the lifting lugs on the VPC-MAX beam.

Complete Disassembly

VPC-MAX beam and trolley removal is now complete.

If necessary, proceed to disassemble the MLC300 for shipping. Refer to Section 4 of the Crane Operator Manual.

NOTE If the crane will be used without the VPC-MAX installed, the VPC trolley mounting frames and the counterweight tray frames must be repositioned as shown in [Figure 4-19 on page 4-30](#).

WIRE ROPE INSTALLATION

Refer to Section 4 of the MLC300 Operator Manual for the following topics:

- Wire Rope Installation
- Rigging Winch Operation
- Load Line Reeving
- Load Block Tieback

THIS PAGE INTENTIONALLY LEFT BLANK

**SECTION 5
LUBRICATION**

TABLE OF CONTENTS

Lubrication5-1
Lube and Coolant Product Guide5-1

FOR REFERENCE ONLY

THIS PAGE INTENTIONALLY LEFT BLANK

SECTION 5 LUBRICATION

LUBRICATION

See F2280, MLC300 Lubrication Guide, at the end of this section.

LUBE AND COOLANT PRODUCT GUIDE

See the publication at the end of this section.

FOR REFERENCE ONLY

FOR REFERENCE ONLY

THIS PAGE INTENTIONALLY LEFT BLANK

SECTION 6 MAINTENANCE

TABLE OF CONTENTS

Boom and Luffing Jib Angle Indicator Calibration	6-1
Automatic Boom Stop Adjustment	6-1
Maintenance	6-1
Adjusting Automatic Boom Stop	6-3
Replacing Boom Stop Limit Switch Actuator Rod	6-3
Block-Up Limit Installation and Adjustment	6-5
General	6-5
Removing Luffing Jib	6-5
Maintenance	6-7
Adjustment	6-7
Boom Hoist Pawl Adjustment	6-9
Limit Switch Adjustment	6-9
Return Spring Adjustment	6-9
Cam Lubrication	6-9
Boom Hoist Pressure Roller Adjustment	6-10
Mast Stop Pressure Check	6-11
Mast Stop Limit Switch Check	6-11
VPC Trolley Limit Switch Checks	6-13
VPC-MAX Beam Limit Switch Checks	6-15
VPC-MAX Trolley Limit Switch Checks	6-17
VPC-MAX Beam-on-Hook Limit Switch Adjustment	6-19

FOR REFERENCE ONLY

THIS PAGE INTENTIONALLY LEFT BLANK

FOR REFERENCE ONLY

SECTION 6 MAINTENANCE

This section contains maintenance and adjustment instructions for the limit devices used with the luffing jib attachment.

For maintenance and inspection of the following components, see the Service Manual supplied with your crane:

- Straps
- Wire Rope
- Load Block and Hook-and-Weight Ball
- Boom and Jib

! WARNING
Avoid Injury

Read, understand, and follow the Safe Maintenance Practices in Section 1 of the Service Manual provided with your MLC300.

BOOM AND LUFFING JIB ANGLE INDICATOR CALIBRATION

Angle sensors ([Figure 6-1](#)) are mounted at the following locations:

- Boom Top
- Boom Butt
- Luffing Jib Top
- Luffing jib Butt

The sensors are calibrated in the RCL/RCI Display and do not require adjustment.



M102472

FIGURE 6-1

AUTOMATIC BOOM STOP ADJUSTMENT

The automatic boom stop limit switch assembly (1, [Figure 6-2](#)) automatically stops the boom (2) and applies the

boom hoist brake if the boom is raised to the maximum boom angle (3)

! WARNING

Falling Attachment Hazard

Do not operate the crane unless the automatic boom stop is properly adjusted and operational. Do not adjust the maximum operating angle higher than specified. The boom could be pulled over backwards or collapse, causing death or serious injury.

When the maximum boom angle is reached, the fault alarm comes on and the boom maximum up icon appears in the information screen of the main display.



To correct the fault once it is activated, lower the boom. The fault cannot be bypassed.

Maintenance

At least once weekly, check that the automatic boom stop stops the boom at the specified maximum boom angle. If it doesn't, replace any worn or damaged parts and/or adjust the automatic boom stop.

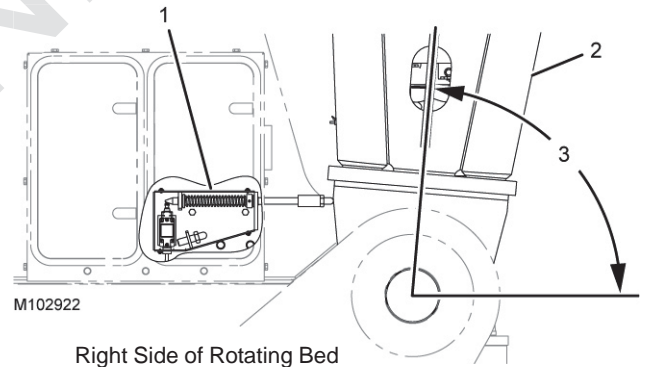

M102922

Item	Description
1	Limit Switch Assembly
2	Boom Butt
3	Maximum boom angle: 85° Boom only with or without VPC-MAX 86° Boom with Luffing Jib and without VPC-MAX 85° Boom with Luffing Jib and with VPC-MAX

FIGURE 6-2

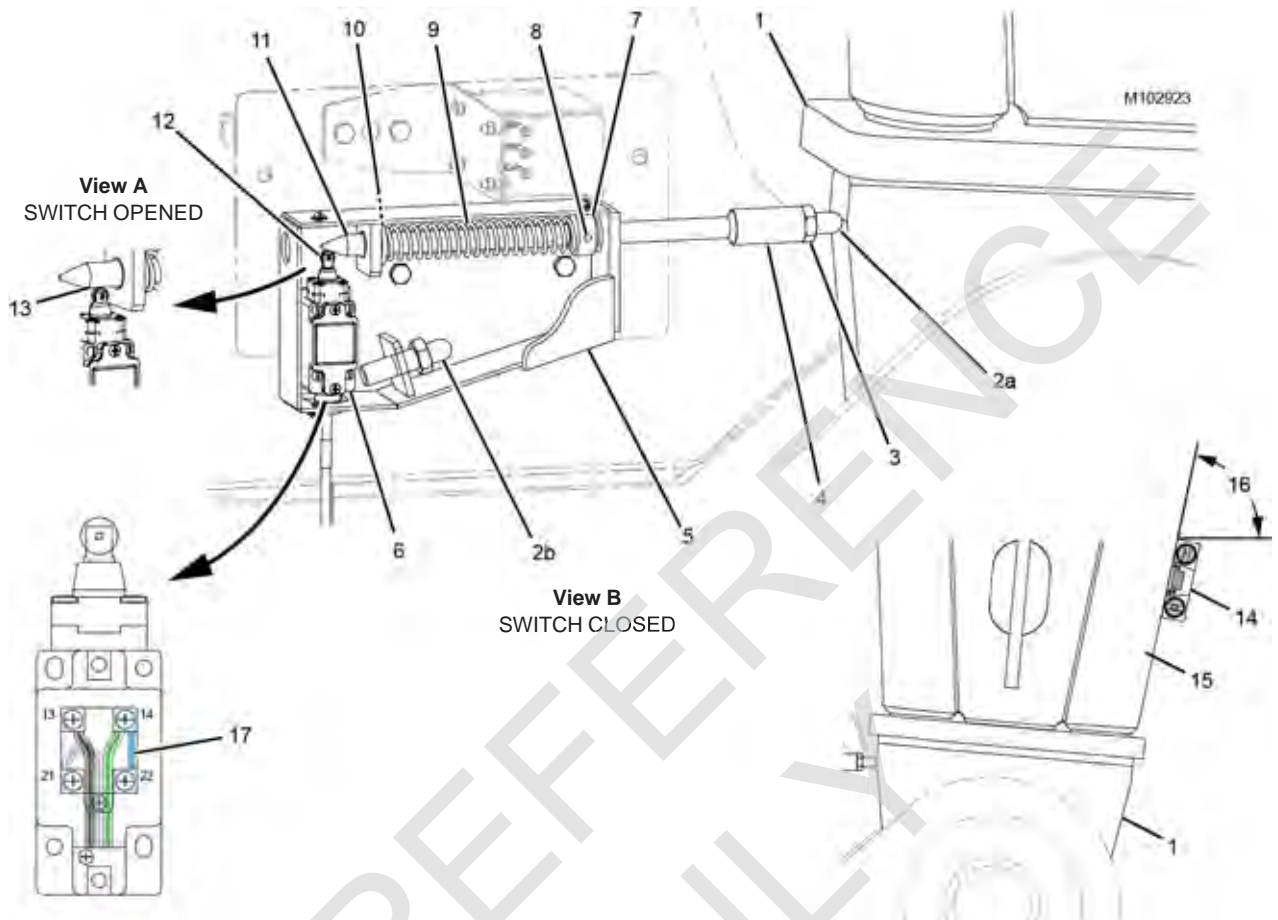

View D Limit Switch Wiring

Wire Color	Switch Terminals	Function
Black	13	Normally Open
Green	14	Input
White	21	Normally Closed
Blue	14 22	Jumper

View C Right Side of Boom Butt

Maximum Boom Angle	Digital Level Angle (16)
85° Boom only with or without VPC-MAX	78°
86° Boom with Luffing Jib and without VPC-MAX	79°
85° Boom with Luffing Jib and with VPC-MAX	78°

Item	Item	Item	Description
1	Boom Butt	9	Spring
2a	Adjusting Rod for 85° Boom Angle: 89 mm (3-1/2 in)	10	Spring Washer
2b	Adjusting Rod for 86° Boom Angle: 85 mm (3-11/32 in)	11	Actuator Rod
3	Jam Nut	12	Switch Closed
4	Coupling (part of actuator rod 11)	13	Over-Travel—Switch Opened
5	Cover	14	Digital Protractor-Level
6	Limit Switch	15	Boom Butt Bottom Chord
7	Spring Washer	16	Digital Level Angle
8	Spring Pin	17	Blue Jumper Wire

FIGURE 6-3

Adjusting Automatic Boom Stop

See [Figure 6-3](#) for the following procedure.

The limit switch for the automatic boom stop was set at the factory and should not require periodic adjustment. Adjustment is necessary when:

- Parts are replaced
- The boom/luffing jib configuration is changed

The following instructions assume that the Rated Capacity Limiter/Indicator (RCL/RCI) is installed and properly calibrated.

During the following procedure, the boom angle is monitored on the working screen of the RCL/RCI and on a digital protractor-level (14, View C).

1. Park the crane on a firm level surface or level the crane by blocking under the crawlers.
2. Check that the proper adjusting rod (2a or 2b) is installed:
 - Rod (2a) for 85°
 - Rod (2b) for 86°
3. Boom up slowly while monitoring the boom angle on the RCL/RCI working screen.
4. Stop booming up when the boom reaches the specified maximum boom angle given in the table for View C.
5. Verify the boom angle with an accurate digital protractor-level (14) placed on the boom butt bottom chord (15) as shown in View C. The corresponding digital level angle (16) should appear on the protractor-level.
 - If the boom stops at the specified angle, further adjustment is not needed.
 - If the boom stops before reaching the specified angle, go to step 6.
 - If the boom reaches the specified angle before it stops, go to step 7.
6. If the boom stops before reaching the specified angle:
 - a. Loosen the jam nut (3, View B).
 - b. Turn the adjusting rod (2a or 2b) all the way into the coupling (4).
 - c. Boom up slowly until the boom reaches the specified angle.
 - d. Turn the adjusting rod (2a or 2b) out against the boom butt (1) until the limit switch (5) “CLICKS” open.
 - e. Tighten the jam nut (3).
7. If the boom reaches the specified angle before it stops:
 - a. Loosen the jam nut (3, View B).
 - b. Turn the adjusting rod (2a or 2b) out against the boom butt (1) until the limit switch (5) “CLICKS” open.
 - c. Tighten the jam nut (3).
8. Check that the actuator rod (11) over-travels the limit switch (13, View A) as shown.
9. Boom down and then back up. The boom must stop at the specified maximum boom angle.
10. If the boom fails to stop, repeat step 3 through step 9.

Replacing Boom Stop Limit Switch Actuator Rod

See [Figure 6-3](#) for the following procedure.

1. Disassemble the unit.
2. Reassemble the unit as shown.
3. Position the actuator rod (4) so the tapered end just touches the limit switch (12) roller. The actuator rod must not depress the limit switch shaft.
4. Drill a 6,35 mm (1/4 in) hole through the spring washer (7) and actuator rod (4).
5. Install the spring pin (8).
6. Push the actuator rod (11) in until the limit switch clicks open. Check the limit switch roller to ensure there is over-travel (13, View A) as shown.
7. Adjust the automatic boom stop.

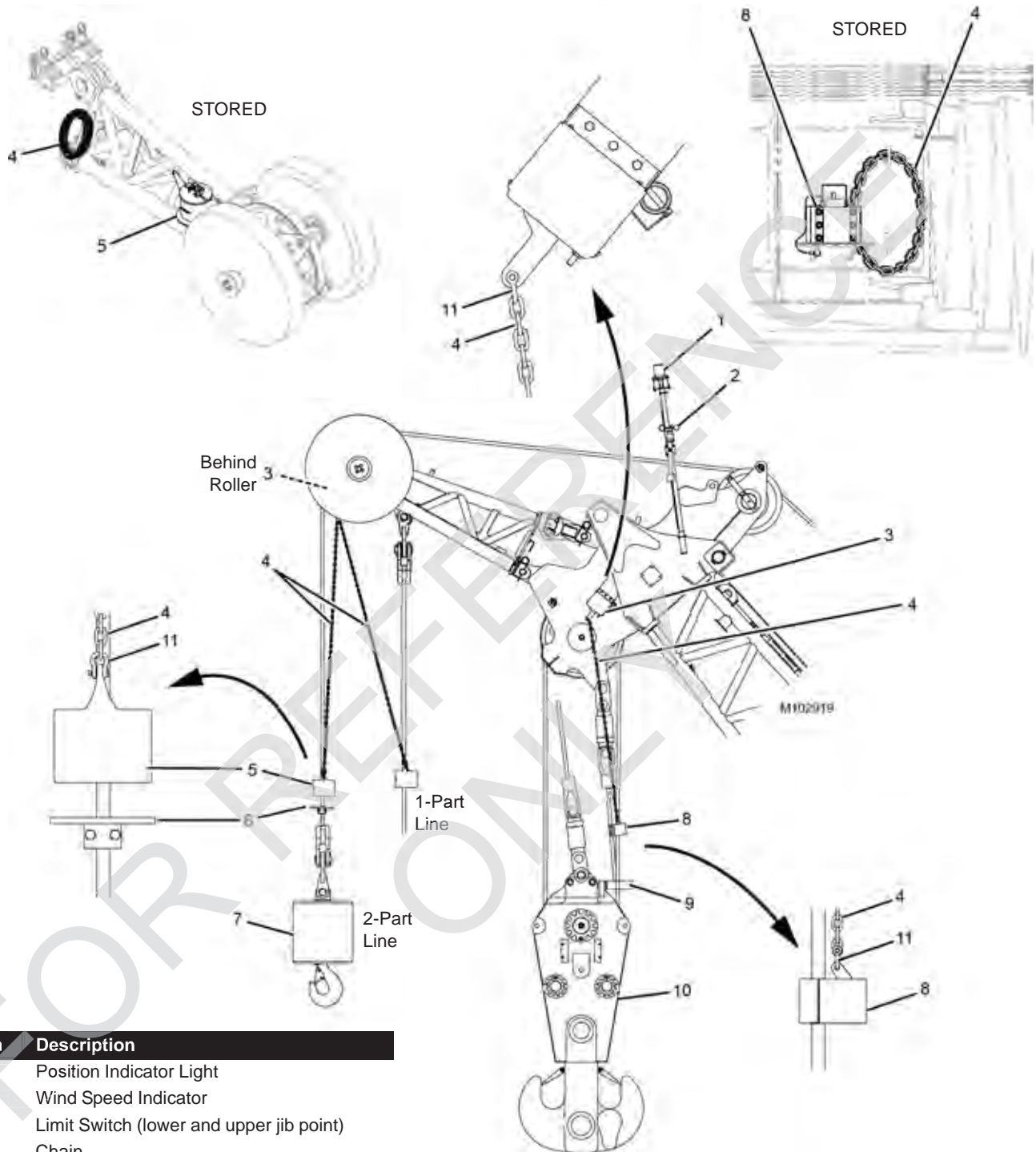

Item	Description
1	Position Indicator Light
2	Wind Speed Indicator
3	Limit Switch (lower and upper jib point)
4	Chain
5	Weight with 2-Chain Attachments
6	Lift Plate
7	Hook-and-Weight Ball
8	Weight with 1-Chain Attachment
9	Lift Block
10	Load Block
11	Shackle

FIGURE 6-4

BLOCK-UP LIMIT INSTALLATION AND ADJUSTMENT



WARNING

Two-Blocking Hazard!

The block-up limit control is a protective device designed only to assist the operator in preventing a two-blocking condition. Any other use is neither intended nor approved.

The block-up limit control may not prevent two-blocking when the load is hoisted at the maximum single line speed. The operator shall determine the fastest line speed that allows the block-up limit control to function properly and, thereafter, not exceed that line speed.

General

The block-up limit control (also called anti two-block device) is a two-blocking prevention device which automatically stops the load drum from hoisting and the luffing jib (and boom) from lowering when a load is hoisted a predetermined distance from either jib point.

DEFINITION: Two-blocking is the unsafe condition in which the load block or the hook-and-weight ball contacts the sheave assembly from which either is suspended.

Two-blocking can result in failure of the sheaves and the wire rope, possibly causing the load to fall.

The luffing jib block-up limit system consists of the following components (Figure 6-4):

8. A normally closed limit switch assembly (3) fastened at either or both of the following locations:
 - a. Lower Jib Point
 - b. Upper Jib Point
9. A weight (5 or 8) freely suspended by the chain (4) from each limit switch actuating lever (weight encircles load line as shown).
10. A lift plate (6) fastened to the load line or a lift block (9) fastened to the load block.

For identification and location of the block-up limit components in the boom, see the Operator and Service Manuals supplied with the crane.

Removing Luffing Jib

When removing the luffing jib (if equipped) it is necessary to disconnect the electric cables from the jib at the electric cables in the boom top.

Be sure to do the following:

1. Thoroughly clean all cable connectors and dust caps.
2. Connect the dust caps to the cable connectors.
3. Connect the terminators to the cables on the boom top.

Failing to perform this step will result in faulty operation. Also, the fault alarm will come on in the main display.

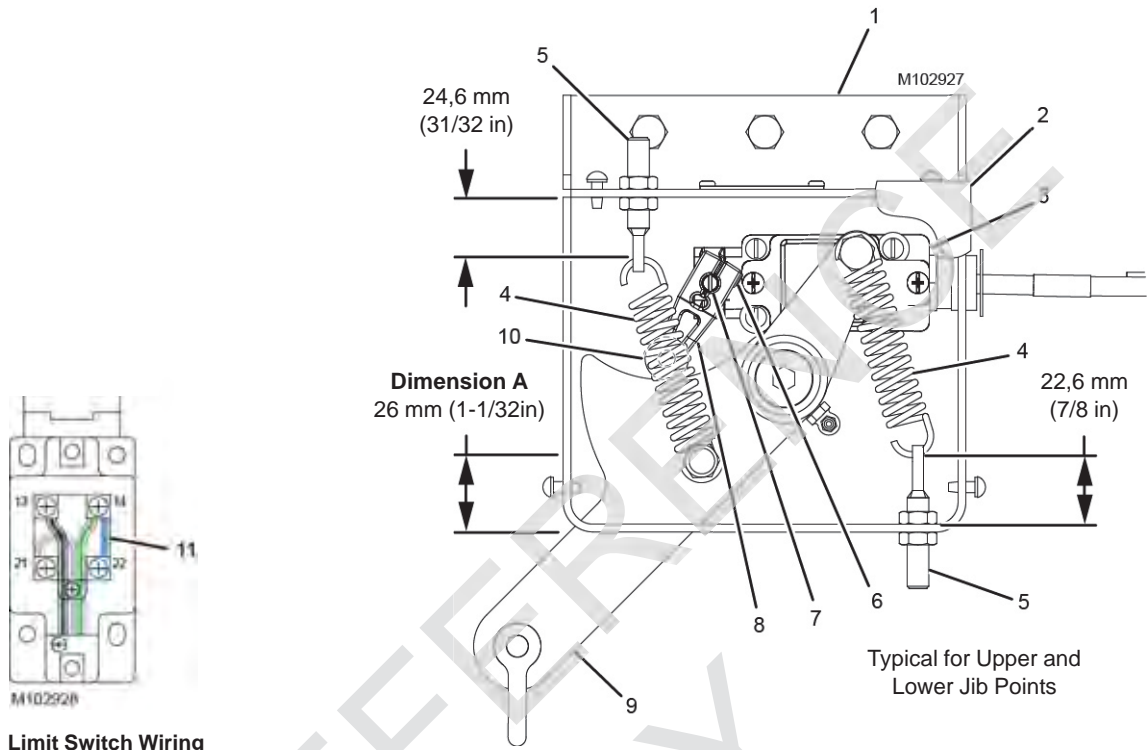

Limit Switch Wiring

Wire Color	Switch Terminals	Function
Black	13	Normally Open
Green	14	Input
White	21	Normally Closed
Blue	14 22	Jumper

Item	Description
1	Bracket
2	Cover
3	Limit Switch
4	Spring (2)
5	Eyebolt with Nuts (2)
6	Set Screw
7	Shaft
8	Limit Switch Lever
9	Actuating Lever
10	Roller
11	Jumper Wire (blue)

FIGURE 6-5

Maintenance

CAUTION

Prevent Damage

To prevent two-blocking from occurring, do not operate crane until cause for improper operation and all hazardous conditions have been found and corrected.

At least once weekly, inspect and test the block-up limit switches, as follows:

1. Lower the boom and jib onto blocking at ground level and carefully inspect the following items:
 - a. Inspect each limit switch lever and actuating lever ([Figure 6-5](#)) for freedom of movement. Apply one-half shot of grease to the fitting on the actuating lever. Wipe away any excess grease.
 - b. Inspect each weight ([Figure 6-4 on page 6-4](#)) for freedom of movement on the load line.
 - c. Inspect each weight, chain, shackle and connecting pin ([Figure 6-4 on page 6-4](#)) for excessive or abnormal wear. Make sure the cotter pins for the shackles are installed and spread.
 - d. Inspect the entire length of the electric cables for damage.
 - e. Check that the electric cables are clear of all moving parts in the boom and jib and that the cables are securely fastened to the boom and jib.
 - f. Check that all cables and terminating plugs are securely fastened.
2. Test the block-up limit controls for proper operation with the engine running using either of the following methods:
 - a. **BOOM AND JIB LOWERED:** Manually lift each weight — **one at a time**. The corresponding load drum should not operate in the up direction and the boom/luffing hoist should not operate in the down direction.
 - b. **BOOM AND JIB RAISED:** **Slowly** hoist each load block and hook-and-weight ball — **one at a time** — against the weight. When the chain goes slack, the

corresponding load drum should stop hoisting and the boom/luffing hoist should not operate in the down direction.

CAUTION

Avoid Sheave Damage

Use extreme care when the testing the block-up limit control when the boom and jib are raised. If the block-up limit control fails to the stop load, immediately stop the load by moving the drum control handle to off. Otherwise, two-blocking may occur.

Adjustment

See [Figure 6-5](#) for the following procedure.

Lower the boom and jib onto blocking at ground level and adjust each limit switch as follows:

1. Remove the cover (1) from the bracket (2).
2. Adjust the tension of both springs (4) with the eyebolts and nuts (5) so there is enough force to lift the weight of the chain and rotate the actuating lever (9) up when the weight is lifted.
The initial setting of eyebolt is shown.
3. Loosen the setscrew (6) in the limit switch lever (8) so the lever is free to rotate.
4. Manually lift the weight to allow the actuating lever (9) to rotate up.
5. Hold the lever (9) at Dimension A.
6. Hold the roller (10) on the limit switch lever (8) against the actuating lever (9) while performing [step 7](#).
7. Turn the limit switch shaft (7) **CLOCKWISE only enough to “CLICK” the limit switch open and hold.**
8. Securely tighten the setscrew (6) in the limit switch lever (8).
9. Test the limit switch for proper operation and repeat the adjustment steps until the limit switch operates properly.
10. Install the cover (1) on the bracket (2).

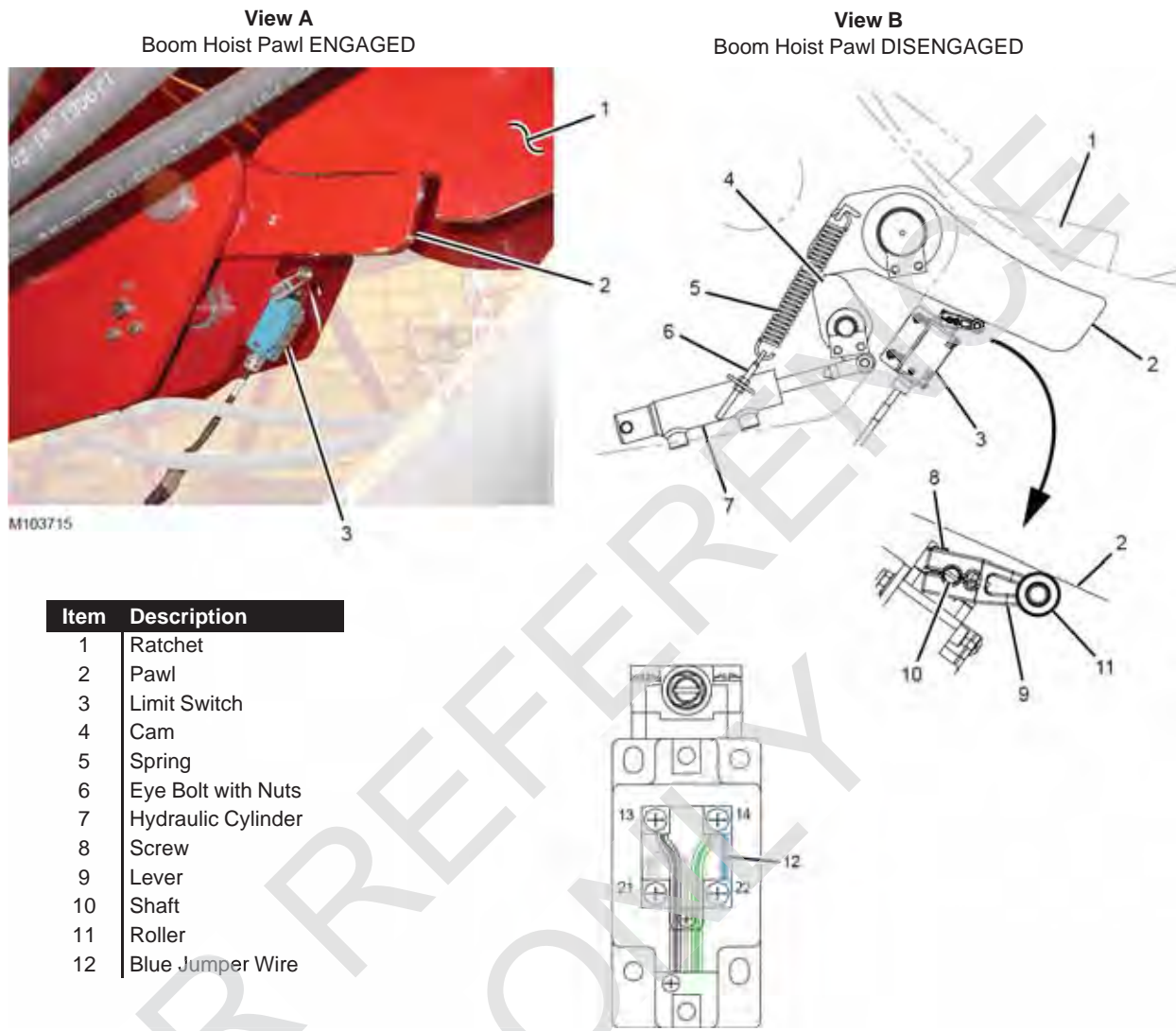

Limit Switch Wiring

Wire Color	Switch Terminals	Function
Black	13	Normally Open
Green	14	Input
White	21	Normally Closed
Blue	14 22	Jumper

FIGURE 6-6

BOOM HOIST PAWL ADJUSTMENT

See [Figure 6-6](#) for the following procedure.

The boom hoist (Drum 5) pawl limit switch must be properly adjusted to ensure proper operation of the hoist.

When the pawl (2, View A) is engaged (Drum 5 parked), the limit switch (3) closes the electric circuit to the crane's programmable controller. This action prevents the boom hoist from being operated in the down direction.

When the pawl (2, View B) is disengaged (Drum 5 un-parked), the limit switch (3) closes the electric circuit to the programmable controller. This action allows the boom hoist to be operated in the up direction.



WARNING

Moving Parts Hazard!

To make adjustments, the engine must be running and the boom hoist and the pawl must be operated.

Avoid injury from moving machinery. Stay clear of the boom hoist drum and the pawl while either is being operated.

Maintain constant communication between the operator and the adjuster so the drum and pawl are not operated while the adjuster is in contact with parts.

Check the boom hoist pawl for proper adjustment each time the VPC-MAX and fixed mast are installed.

Limit Switch Adjustment

1. Loosen the screw (8, View C) so limit switch lever (9) is free to rotate on the shaft (10).

2. Disengage the boom hoist pawl by moving the Drum 5 park switch to the un-parked position. It may be necessary to boom up slightly before the pawl will disengage the ratchet.
3. Rotate the lever (9) up and hold it so the roller (11) is against the pawl (2).
4. Turn the limit switch shaft (10) **clockwise** until limit switch clicks open and hold.
5. Make sure the roller is against the pawl and securely tighten the screw (8) to lock adjustment.
6. Check for proper operation:
 - Engage the boom hoist pawl by moving the Drum 5 park switch to the parked position and try to boom down. **The boom hoist should not operate in down direction.**
 - Disengage the boom hoist pawl by moving the Drum 5 park switch to the un-parked position and try to boom down. The boom hoist should operate in the down direction.
7. Readjust the limit switch if required.

Return Spring Adjustment

Adjust the eyebolt (6, View B) so the return spring (5) has enough tension to fully engage and hold the pawl (2) against the ratchet (1).

Cam Lubrication

Spray or brush an anti-seizing lubricant on the sliding surface between the cam (4, View B) and the pawl (2).

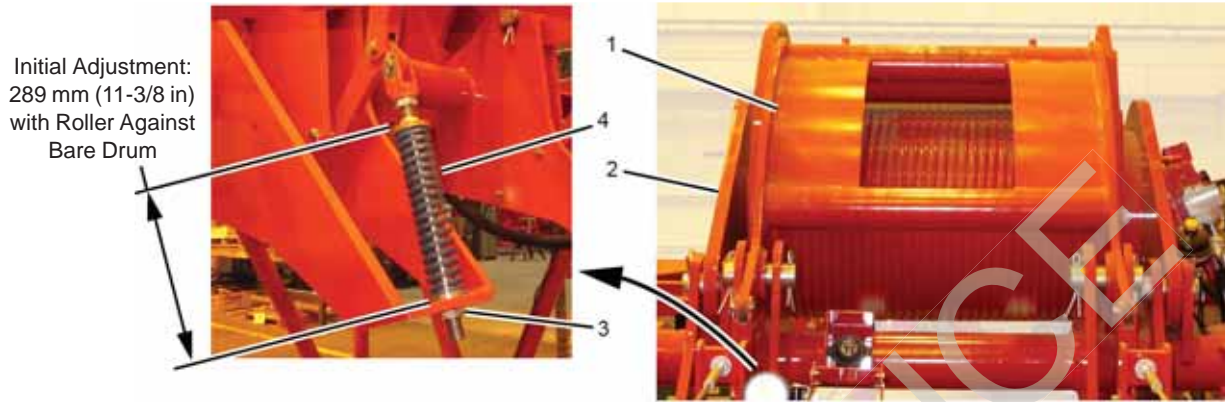

Item	Description	Item	Description
1	Pressure Roller	3	Lock Nut
2	Boom Hoist (Drum 5)	4	Spring

FIGURE 6-7



Pressure Reading Cylinder Part #84030450		Pressure Reading Cylinder Part #84034173	
19,1 bar at -1°C	277 psi at 30°F	12,7 bar at -1°C	185 psi at 30°F
19,5 bar at 4°C	283 psi at 40°F	13,0 bar at 4°C	189 psi at 40°F
19,9 bar at 10°C	289 psi at 50°F	13,3 bar at 10°C	192 psi at 50°F
20,3 bar at 16°C	294 psi at 60°F	13,5 bar at 16°C	196 psi at 60°F
20,7 bar at 21°C	300 psi at 70°F	13,8 bar at 21°C	200 psi at 70°F
21,1 bar at 27°C	306 psi at 80°F	14,0 bar at 27°C	204 psi at 80°F
21,5 bar at 32°C	311 psi at 90°F	14,3 bar at 32°C	208 psi at 90°F
21,9 bar at 38°C	317 psi at 100°F	14,6 bar at 38°C	211 psi at 100°F

NOTE The cylinder part number is provided on the identification plate on each cylinder.

Item	Description
1	Mast Stop Gauge (2)

FIGURE 6-8

BOOM HOIST PRESSURE ROLLER ADJUSTMENT

See [Figure 6-7](#) for the following procedure.

The pressure roller (1) is spring loaded to assist in maintaining proper wire rope spooling by holding the wire rope firmly in place on the boom hoist (2).

The operator should visually monitor drum spooling during daily during operation.

If the wire rope jumps layers or does not wind smoothly onto the boom hoist drum, proceed as follows:

1. Correct the wire rope spooling.
2. Tighten the lock nut (3) to increase spring tension.

WARNING

Crush Hazard!

The pressure roller is spring loaded. Stop the boom hoist drum and turn off the engine before adjusting.

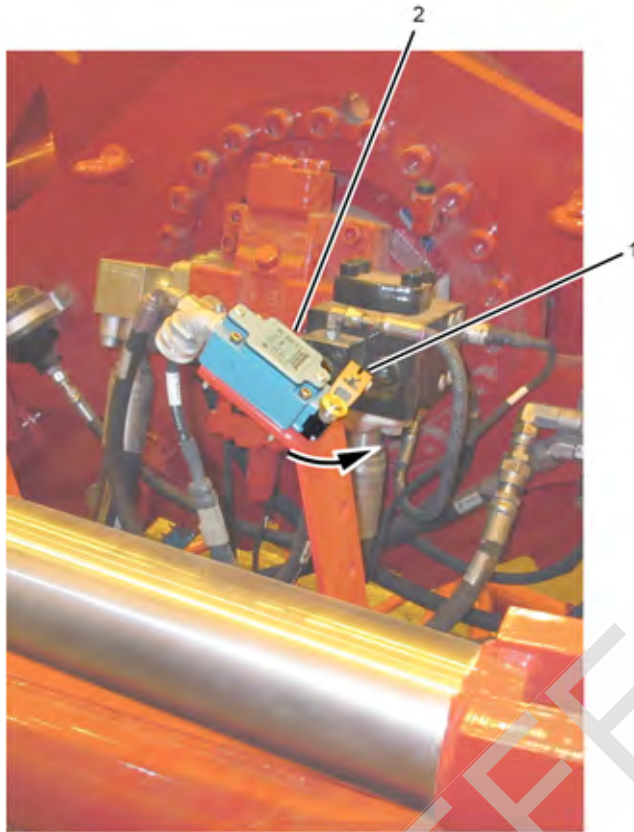

M103726

Item	Description
1	Lever
2	Mast Stop Limit Switch

Limit Switch Wiring

Wire Color	Switch Terminals	Function
Black	13	Normally Open
Green	14	Input
White	21	Normally Closed
Blue	14 22	Jumper

FIGURE 6-9

MAST STOP PRESSURE CHECK

WARNING
Explosion Hazard!

The mast stops are equipped with nitrogen pre-charged accumulators.

Do not tamper with the accumulators unless authorized and trained to do so.

Each mast stop has a hydraulic pressure gauge (1, [Figure 6-8](#)).

Check both gauges weekly to verify that they read the proper pressure as listed in the table in [Figure 6-8](#).

Take corrective action if either gauge does not read the proper pressure. Contact the Manitowoc Crane Care Lattice Team.

MAST STOP LIMIT SWITCH CHECK

See [Figure 6-9](#) for the following procedure.

The mast stop limit switch must be checked each time the VPC-MAX attachment is installed.

1. If necessary, reposition the lever (1) so it is perpendicular (90°) to the body of the mast stop limit switch (2).
2. Start the engine (if off).
3. Make sure the fixed mast configuration is selected in the RCL/RCI Display.
4. Rotate the lever (1) counterclockwise.
5. The hazard warning should come on and the MAST STOP FAULT icon should appear in the fault bar of the main display.
6. Release the lever (1). The hazard warning and MAST STOP FAULT icon should go off.
7. If the fault does not appear in the main display, troubleshoot the electric control system and correct the problem.



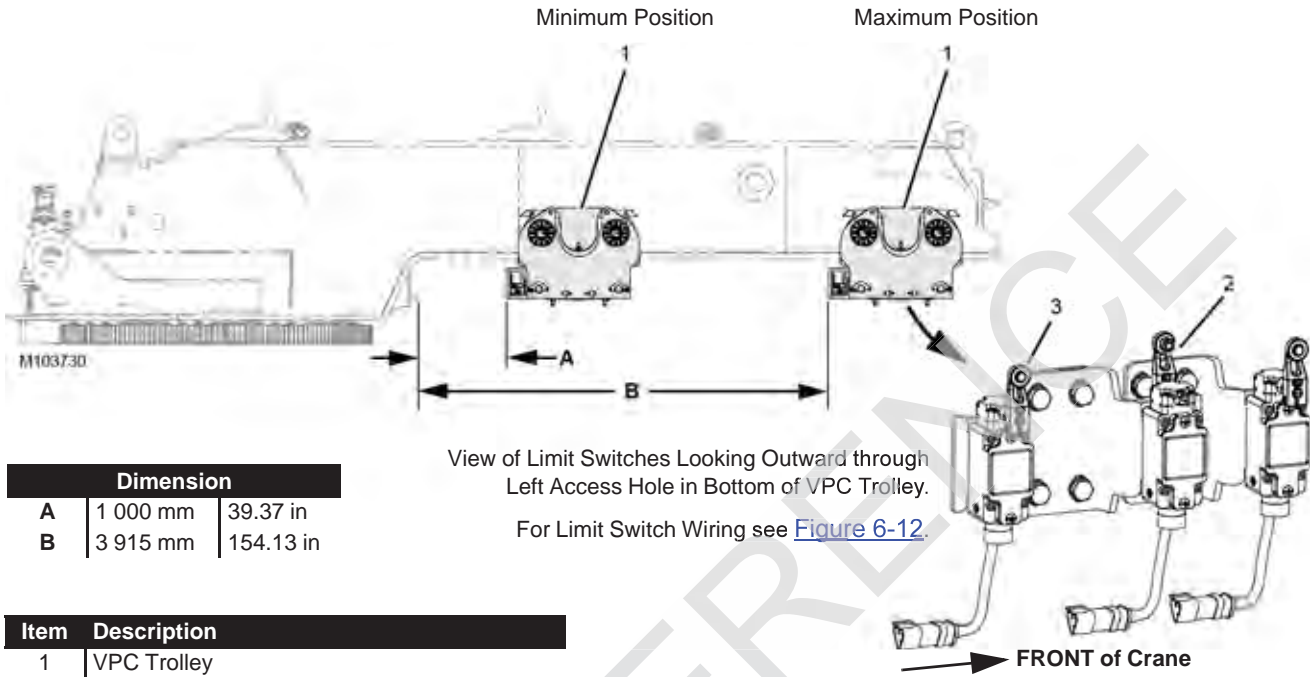

FIGURE 6-10

Dimension		
A	1 000 mm	39.37 in
B	3 915 mm	154.13 in

Item	Description
1	VPC Trolley
2	Limit Switch: VPC Trolley Minimum Position
3	Limit Switch: VPC Trolley Maximum Position

Item	Description
A	VPC Trolley Minimum Position
B	VPC Trolley Maximum Position
2	Limit Switch: VPC Trolley Minimum Position
3	Limit Switch: VPC Trolley Maximum Position

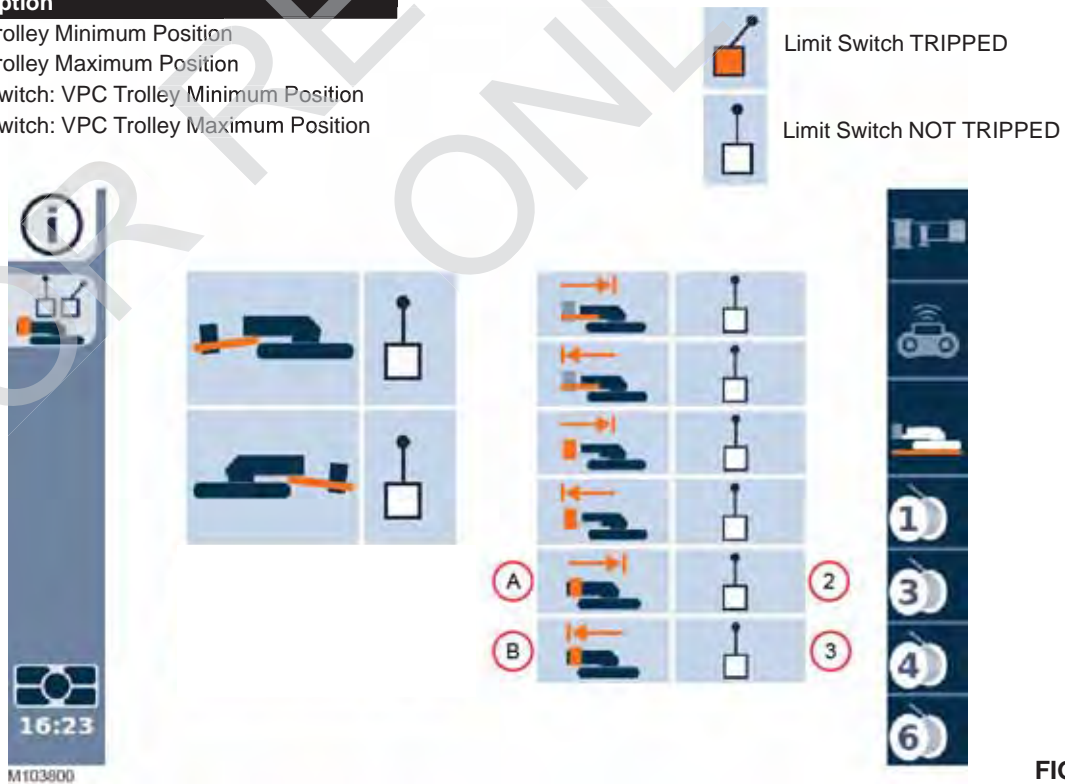

FIGURE 6-11

VPC TROLLEY LIMIT SWITCH CHECKS

Perform the VPC trolley limit switch checks:

- Each time the crane is assembled at a new job site
 - Each time the VPC-MAX attachment is installed
1. Verify that all three limit switch levers are installed parallel to the VPC trolley limit switch housings. **The levers must be positioned straight up-and-down on the shafts.**

To access the limit switches, remove the access cover over the hole in the bottom left end of the VPC trolley. Reinstall the cover when done.

2. With the remote control on and the live mast configuration selected in the RCL/RCI display, proceed as follows:

- a. Access the limit switch status information screen in the main display ([Figure 6-11](#)).
- b. Using the switch on the remote control, position the VPC trolley (1, [Figure 6-10](#)) at dimension A.
- c. In the main display ([Figure 6-11](#)), the minimum position (A) limit switch icon (2) must indicate that the limit switch is TRIPPED.

If the icon indicates that the limit switch is NOT TRIPPED, troubleshoot the electric control system and fix the problem.

The limit switch (2) must be TRIPPED when the VPC trolley is at the minimum position.

- d. Using the switch on the remote control, position the VPC trolley (1, [Figure 6-10](#)) at dimension B.
- e. In the main display ([Figure 6-11](#)), the maximum position (B) limit switch icon (3) must indicate that the limit switch is TRIPPED.

If the icon indicates that the limit switch is NOT TRIPPED, troubleshoot the electric control system and fix the problem.

The limit switch (3) must be TRIPPED when the VPC trolley is at the maximum position.

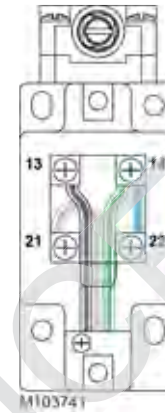

Limit Switch Wiring

Wire Color	Switch Terminals	Function
Black	13	Normally Open
Green	14	Input
White	21	Normally Closed
Blue	14 22	Jumper

The limit switch wiring in this illustration applies to the following limit switches:

- VPC Trolley (3)
- VPC-MAX Trolley (2)
- VPC-MAX Beam-on-Hook (2)
- VPC-MAX Beam Max Up

FIGURE 6-12

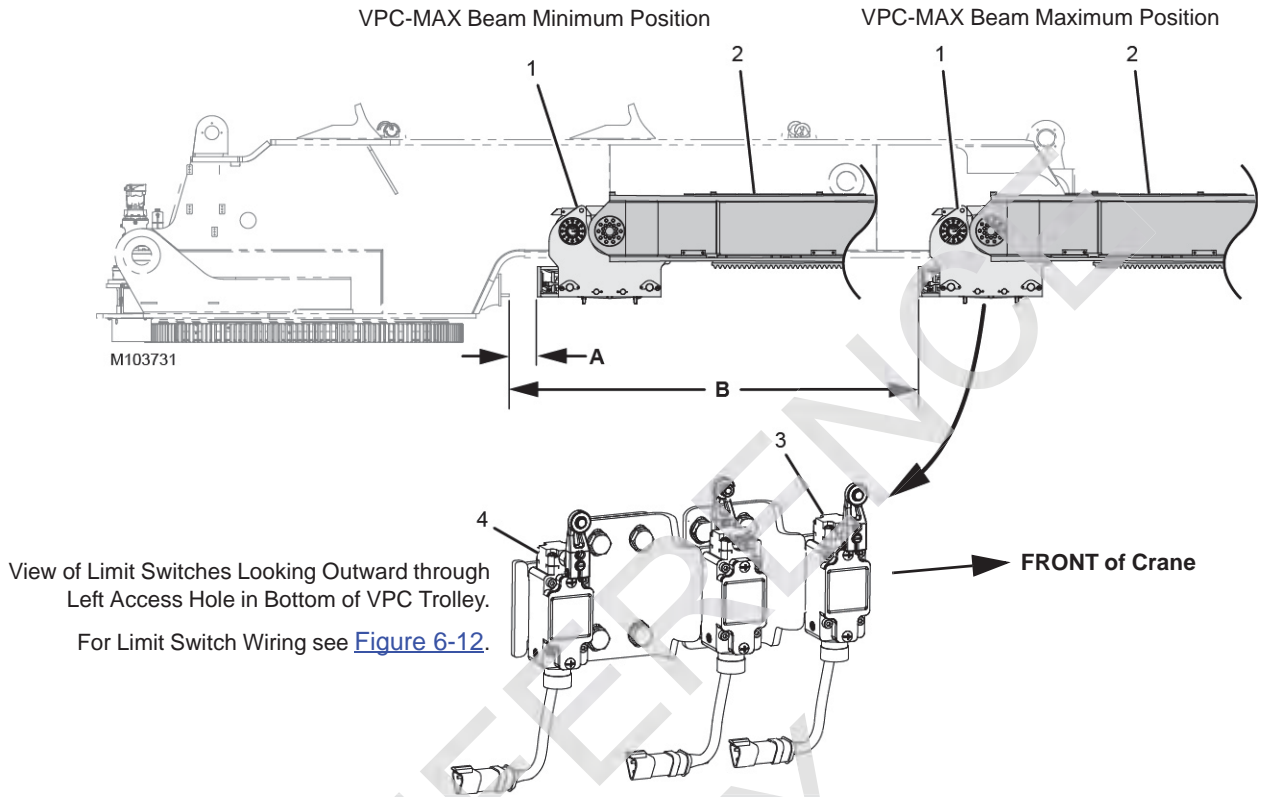

Dimension		Item	Description
A	220 mm 8.66 in	1	VPC Trolley
B	3 915 mm 154.13 in	2	VPC-MAX Beam
		3	Limit Switch: VPC-MAX Beam Minimum Position
		4	Limit Switch: VPC-MAX Beam Maximum Position

FIGURE 6-13

Item	Description
A	VPC-MAX Beam Minimum Position
B	VPC-MAX Beam Maximum Position
3	Limit Switch: VPC-MAX Beam Minimum Position
4	Limit Switch: VPC-MAX Beam Maximum Position

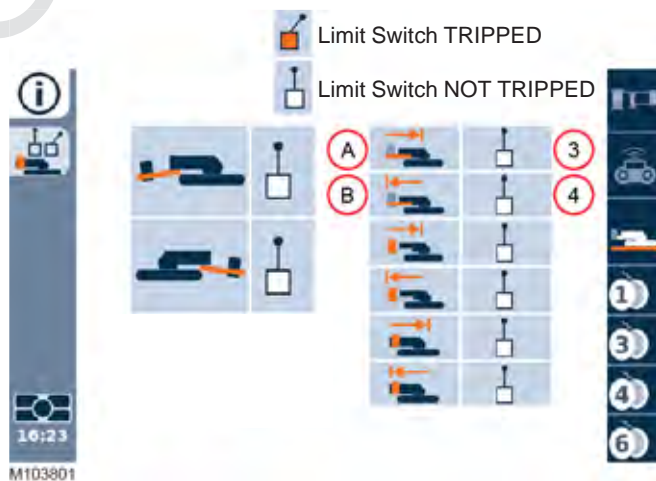

FIGURE 6-14

VPC-MAX BEAM LIMIT SWITCH CHECKS

Perform the VPC-MAX beam limit switch checks each time the VPC-MAX attachment is installed.

1. Verify that all three limit switch levers are installed parallel to the VPC trolley limit switch housings as shown in [Figure 6-13](#). **The levers must be positioned straight up-and-down on the shafts.**

To access the limit switches, remove the access cover over the hole in the bottom left end of the VPC trolley. Reinstall the cover when done.

2. With the remote control on and the fixed mast configuration selected in the RCL/RCI display, proceed as follows:
 - a. Perform this procedure immediately after the VPC-MAX beam is attached to the VPC trolley and while the assist crane is still supporting the rear end of the beam as shown in [Figure 6-15](#).
 - b. Access the limit switch status information screen in the main display ([Figure 6-14](#)).
 - c. Using the switch on the remote control, position the VPC trolley (1, [Figure 6-13](#)) at dimension A. Follow with the assist crane while performing this step.

- d. In the main display ([Figure 6-14](#)), the minimum position (A) limit switch icon (3) must indicate that the limit switch is TRIPPED.

If the icon indicates that the limit switch is NOT TRIPPED, troubleshoot the electric control system and fix the problem.

The limit switch (3) must be TRIPPED when the VPC-MAX beam is at the minimum position.

- e. Using the switch on the remote control, position the VPC trolley (1, [Figure 6-13](#)) at dimension B. Follow with the assist crane while performing this step.
- f. In the main display ([Figure 6-14](#)), the maximum position (B) limit switch icon (4) must indicate that the limit switch is TRIPPED.

If the icon indicates that the limit switch is NOT TRIPPED, troubleshoot the electric control system and fix the problem.

The limit switch (4) must be TRIPPED when the VPC-MAX beam is at the maximum position.

- g. With the assist crane still attached to the beam, perform the [VPC-MAX Beam-on-Hook Limit Switch Adjustment](#) on page 6-19.

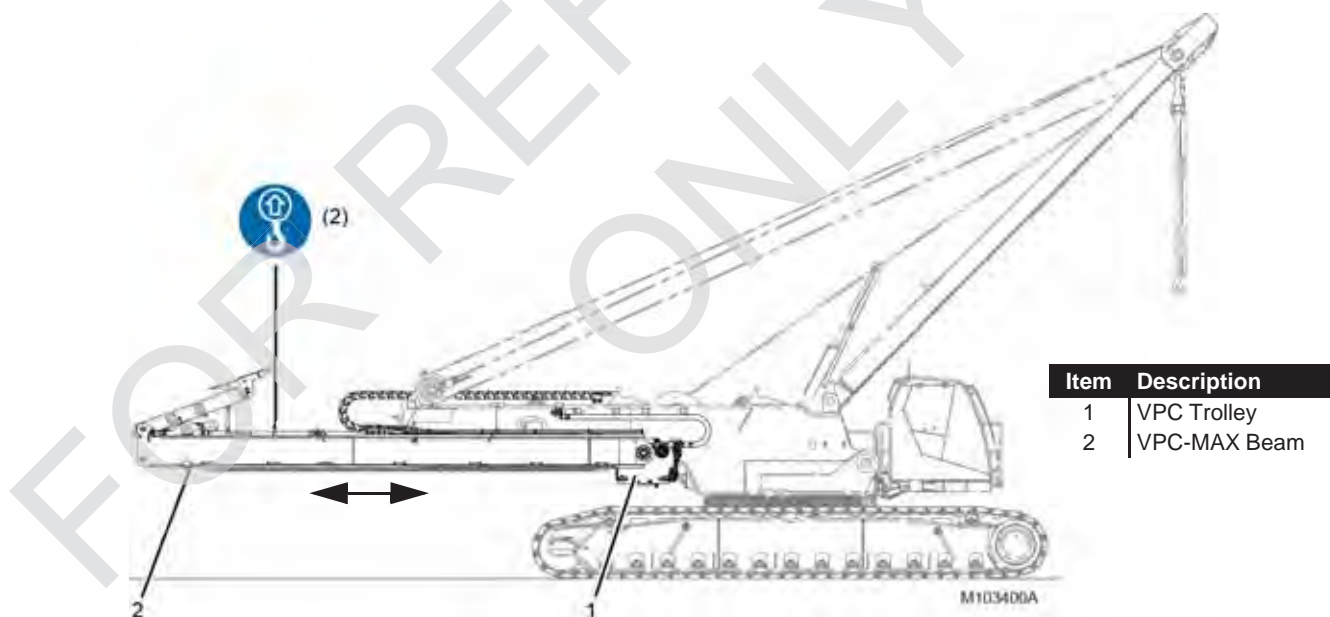

FIGURE 6-15

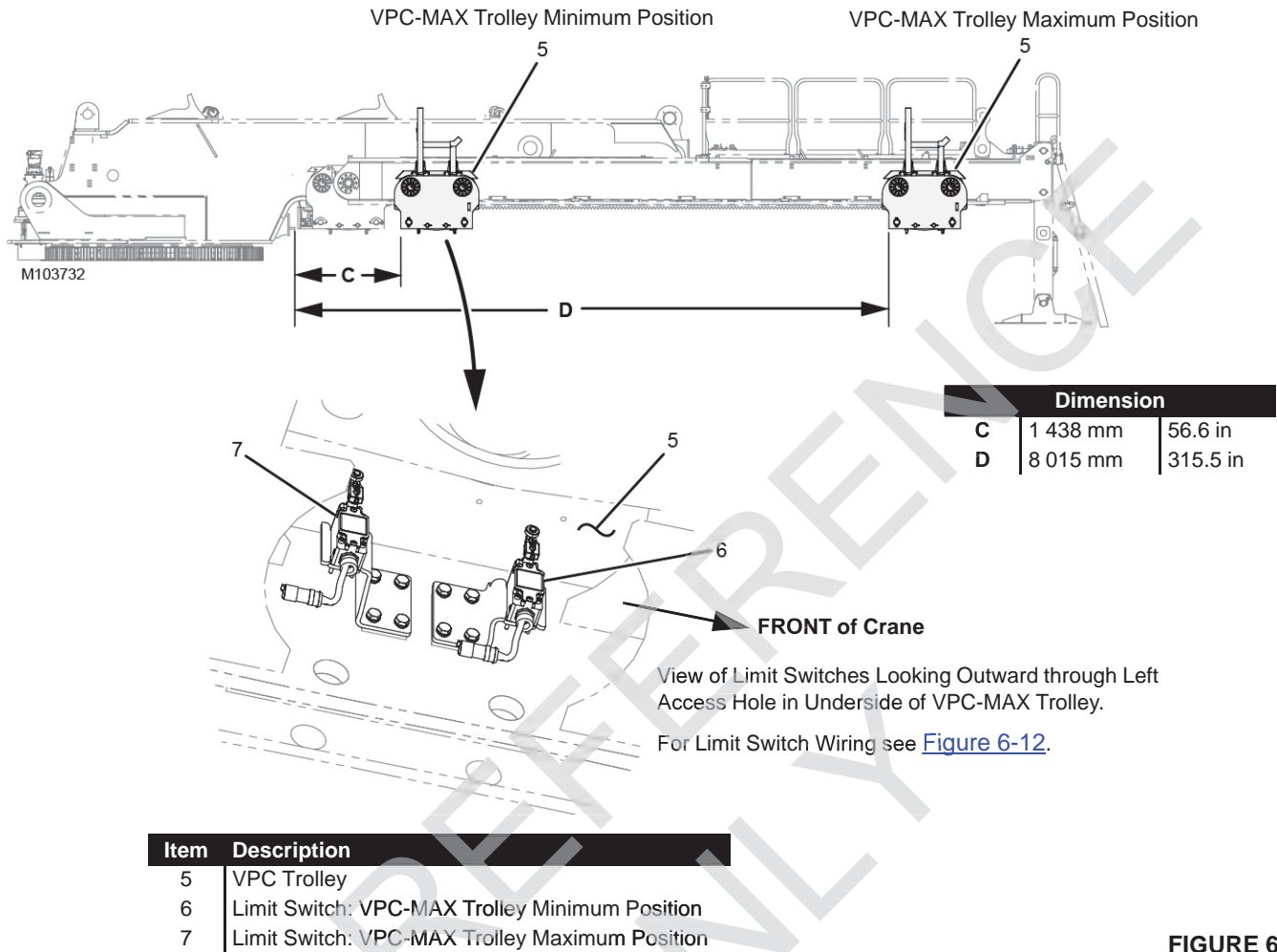

FIGURE 6-16

Item	Description
C	VPC-MAX Trolley Minimum Position
D	VPC-MAX Trolley Maximum Position
6	Limit Switch: VPC-MAX Trolley Minimum Position
7	Limit Switch: VPC-MAX Trolley Maximum Position

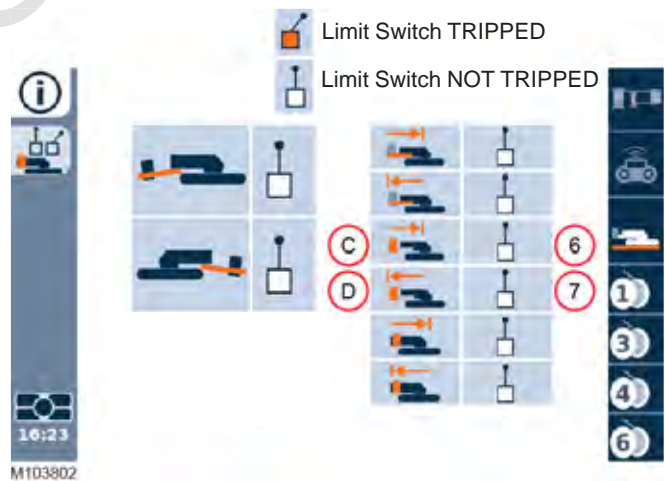

FIGURE 6-17

VPC-MAX TROLLEY LIMIT SWITCH CHECKS

Perform the VPC-MAX beam limit switch checks each time the VPC-MAX attachment is installed.

1. Verify that both limit switch levers are installed parallel to the VPC trolley limit switch housings as shown in [Figure 6-16](#). **The levers must be positioned straight up-and-down on the shafts.**

To access the limit switches, remove the access cover over the hole in the bottom left end of the VPC trolley. Reinstall the cover when done.

2. With the remote control on and the fixed mast configuration selected in the RCL/RCI display, proceed as follows:
 - a. Access the limit switch status information screen in the main display ([Figure 6-17](#)).
 - b. Using the switch on the remote control, position the VPC-MAX trolley (5, View C, [Figure 6-16](#)) at dimension C.
 - c. In the main display ([Figure 6-17](#)), the minimum position (C) limit switch icon (6) must indicate that the limit switch is TRIPPED.

If the icon indicates that the limit switch is NOT TRIPPED, troubleshoot the electric control system and fix the problem.

The limit switch (6) must be TRIPPED when the trolley is at the minimum position.

- d. Using the switch on the remote control, position the VPC-MAX trolley (5, View D, [Figure 6-16](#)) at dimension B. Follow with the assist crane while performing this step.
- e. in the main display ([Figure 6-17](#)), the maximum position (D) limit switch icon (7) must indicate that the limit switch is TRIPPED.

If the icon indicates that the limit switch is NOT TRIPPED, troubleshoot the electric control system and fix the problem.

The limit switch (7) must be TRIPPED when the trolley is at the maximum position.

For Limit Switch Wiring see [Figure 6-12](#).

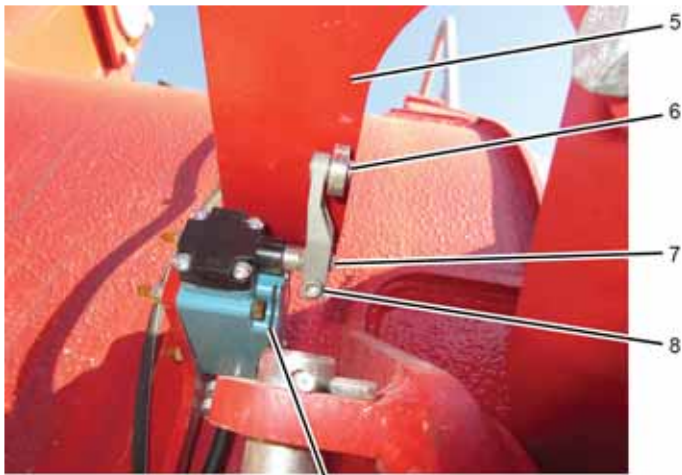

Item	Description
1	Limit Switch: Beam-on-Hook (right side)
2	VPC-MAX Beam
3	Pin
4	Rear of Rotating Bed
5	Actuator
6	Limit Switch Lever
7	Limit Switch Shaft
8	Set Screw
9	VPC Trolley
10	Stop Block (2)

View B

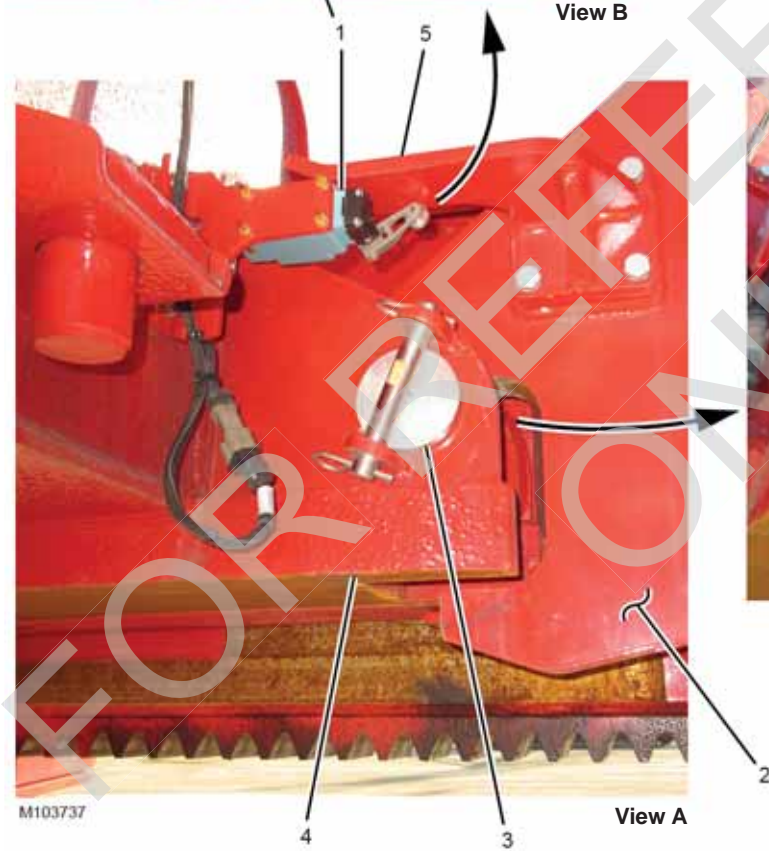

View A

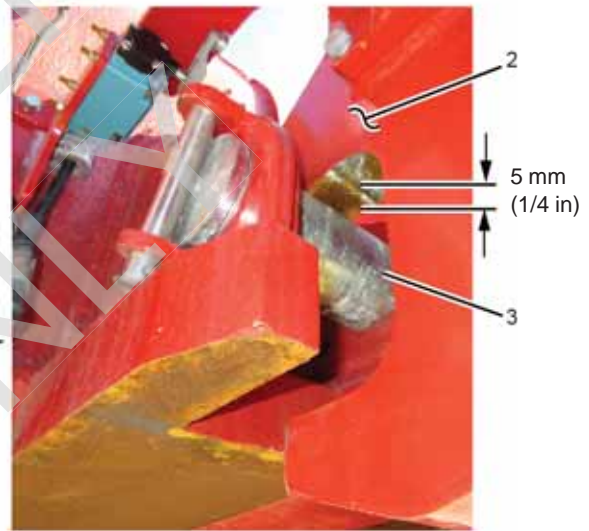

View C

FIGURE 6-18

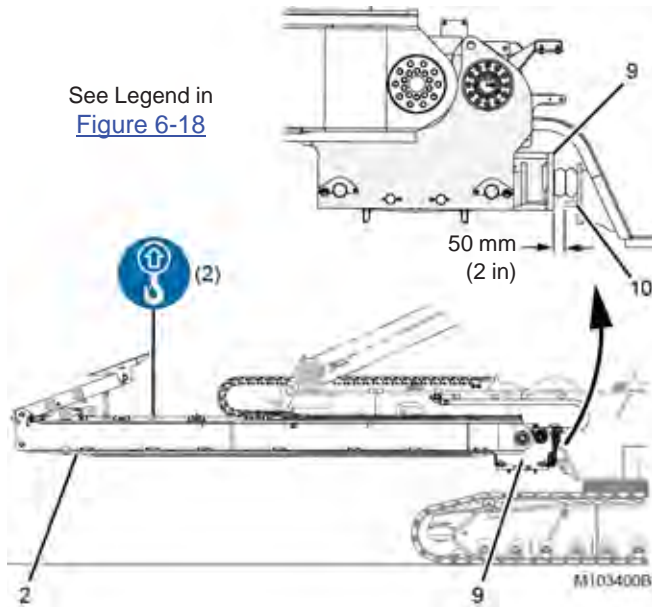

FIGURE 6-19

VPC-MAX BEAM-ON-HOOK LIMIT SWITCH ADJUSTMENT

Perform the VPC-MAX beam-on-hook limit switch adjustment each time the VPC-MAX attachment is installed.

1. Perform this procedure immediately after the VPC-MAX beam (2, [Figure 6-19](#)) is attached to the VPC trolley (9) and while the assist crane is still supporting the rear end of the beam.
 - a. Using the switch on the remote control, position the VPC trolley (9, [Figure 6-19](#)) so it is 50 mm (2 in) from the stop block (10). Follow with the assist crane while performing this step.

See [Figure 6-18](#) for the remaining steps.
 - b. At both beam-to-hook limit switches (1, View B), loosen the setscrew (8) so the limit switch lever (6) is free to rotate on the limit switch shaft (7).
 - c. Using the assist crane, position the VPC-MAX beam (2, View C) so the distance from the underside of the beam hook to the top of the pin (3) is 5 mm (1/4 in).
 - d. Hold each limit switch lever (6, View B) so the roller is touching the underside of the actuator (5).
2. With the remote control on and the fixed mast configuration selected in the RCL/RCI display, proceed as follows:
 - a. Using the switch on the remote control, position the VPC trolley (9, [Figure 6-19](#)) so it is 50 mm (2 in) from the stop block (10). Follow with the assist crane while performing this step.

See [Figure 6-18](#) for the remaining steps.
 - b. At both beam-to-hook limit switches (1, View B), loosen the setscrew (8) so the limit switch lever (6) is free to rotate on the limit switch shaft (7).
 - c. Using the assist crane, position the VPC-MAX beam (2, View C) so the distance from the underside of the beam hook to the top of the pin (3) is 5 mm (1/4 in).
 - d. Hold each limit switch lever (6, View B) so the roller is touching the underside of the actuator (5).

- e. Turn each limit switch shaft (7, View B) in the following direction until the limit switch “clicks” and hold.
 - COUNTERCLOCKWISE for right side limit switch (when viewing shaft)
 - CLOCKWISE for left side limit switch (when viewing shaft)
- f. Securely tighten the setscrews (8, View B).
- g. Using the assist crane, raise the VPC-MAX beam so the actuators (5, View B) are clear of the limit switch levers (6).
- h. Repeat [step c](#). The following should occur:
 - In the limit switch status screen in the main display ([Figure 6-18](#)), the beam-on-hook limit switch icons (1A and 1B) must indicate that the limit switches are TRIPPED.
 - The hazard warning must come on and the BEAM-ON-HOOK icon must appear in the fault bar of the main display.

If either of the above does not occur, repeat the adjustment procedure or troubleshoot the electric control system and fix the problem.

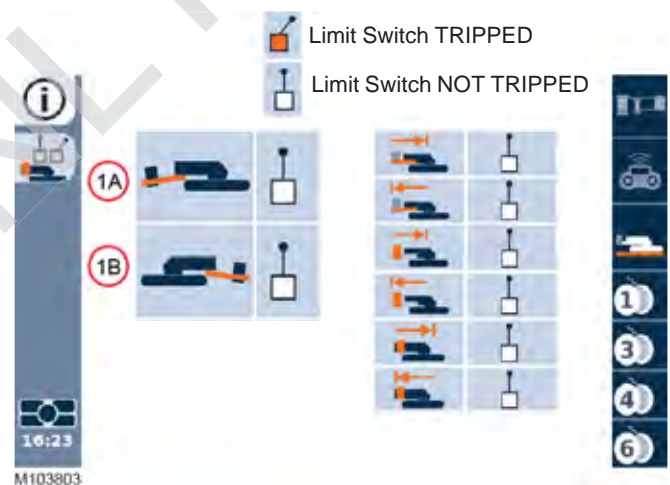

Item	Description
1A	Limit Switch: Beam-on-Hook (right side)
1B	Limit Switch: Beam-on-Hook (left side)

FIGURE 6-20

THIS PAGE INTENTIONALLY LEFT BLANK

FOR REFERENCE ONLY

ALPHABETICAL INDEX

Assembling, Disassembling, or Operating Crane Near Electric Power and Transmission Lines	2-19
Accessing Parts	4-2
Accidents	2-21
Assist Crane Requirements	4-3
Automatic Boom Stop Adjustment	6-1
Auxiliary Frame Assembly Operating Positions	3-5
Auxiliary Frame Operating Positions	4-95
Block-Up Limit Installation and Adjustment	6-5
Boom and Jib Assembly Drawings	4-2
Boom and Luffing Jib Angle Indicator Calibration	6-1
Boom Disassembly Safety	2-25
Boom Hoist Pawl Adjustment	6-9
Boom Hoist Pressure Roller Adjustment	6-10
Change of Ownership Registration	1-1
Connecting/Disconnecting Hydraulic Hoses and Electric Cables	4-8
Continuous Innovation	2-1
Crane Access Points	2-4
Crane and VPC-MAX Setup	4-7
Crane Data	1-1
Crane Orientation	1-1
Crane Orientation	4-2
Crane Weights and Shipping Data	4-3
Crane Weights	1-1
Crane/Attachment Identification	1-1
English and Metric Conversions	1-4
Environmental Protection	2-23
Fire Extinguishers	2-21
Fixed Mast Lowering Methods	4-99
Fixed Mast Raising Methods	4-71
General Safety	4-1
General Set-Up and Installation	4-1
Getting On or Off Crane	2-4
Handling Components	4-2
Hose and Cable Cleanliness	4-8
Hydraulic Hose Identification	4-8
Identification and Location of Components	1-2
Installing VPC-MAX #503 Fixed Mast	4-51
Installing VPC-MAX Beam and Trolley	4-13
Introduction	1-1
Lifting Slings and Shackles	4-3
Lowering Boom	4-97
Lowering Fixed Mast — Alternate Method with Anchored Holdback	4-111
Lowering Fixed Mast — Preferred Method with Boom Holdback	4-99
Lube and Coolant Product Guide	5-1
Lubrication	5-1
Lubrication	5-1
Maintenance	6-1
Manitowoc Dealer	1-1
Mast Stop Limit Switch Check	6-11
Mast Stop Pressure Check	6-11
Nameplates and Decals	2-1
Operating Conditions During Assembly and Disassembly	4-11
Operating Controls And Procedures	3-1

Operating Controls and Procedures	3-3
Operating Precautions	3-3
Operational Aids	2-17
Operator Manual/Capacity Chart Storage	2-10
Outline Dimensions	1-1
Parts Box	4-3
Pedestal/Barge Mounted Cranes	2-27
Personal Fall-Protection	2-9
Personal Fall-Protection	4-2
Personnel Handling Policy	2-26
Pin and Connecting Hole Cleanliness	4-8
Raising Boom	4-92
Raising Fixed Mast — Alternate Method with Anchored Holdback	4-86
Raising Fixed Mast — Preferred Method with Boom Holdback	4-73
Refueling	2-21
Remote Control	4-6
Removing VPC-MAX #503 Fixed Mast	4-115
Removing VPC-MAX Beam and Trolley	4-135
Retaining Connecting Pins	4-3
Safe Maintenance	2-21
Safe Operating Practices	2-11
Safety and Information Signs	2-3
Safety Devices	2-17
Safety Information	2-1
Safety Messages	2-1
Set-Up and Installation	4-1
Shipping Crane Components	4-97
Signals	2-16
Standard Hand Signals for Controlling Crane Operations	3-2
Target Tension During Fixed Mast Raising and Lowering	4-71
Tightening Hydraulic Couplers	4-8
VPC Trolley Limit Switch Checks	6-13
VPC-MAX Beam Limit Switch Checks	6-15
VPC-MAX Beam-on-Hook Limit Switch Adjustment	6-19
VPC-MAX Trolley Limit Switch Checks	6-17
Wire Rope Installation	4-163

FOR REFERENCE ONLY

FOR REFERENCE ONLY