

## Igo T 130

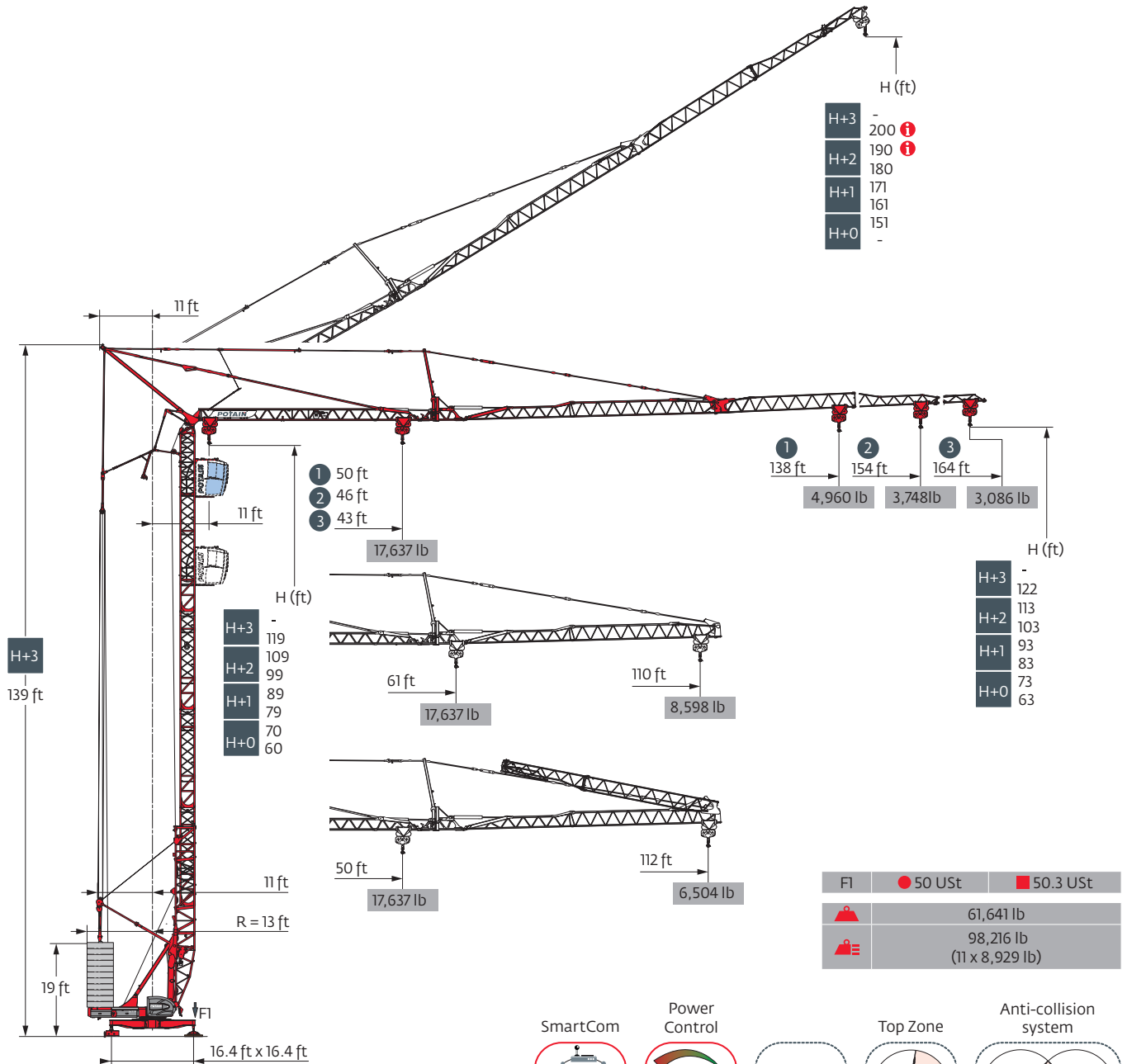

❗ North American market utilizes 12 counterweight slabs, please consult factory for dimensions information.



Load curves

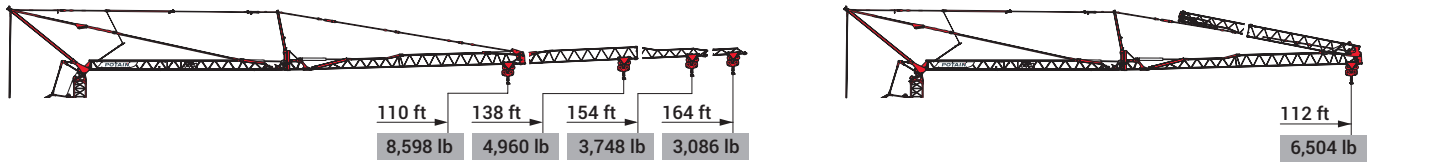

164 ft	11	▶	43	46	52	59	66	72	74	75	79	85	92	98	105	112	118	125	131	138	144	151	157	164	ft
▲▲▲																									lb
																									lb
																									lb
154 ft	11	▶	46	49	52	59	66	72	79	80	82	85	92	98	105	112	118	125	131	138	144	151	154	ft	
▲▲▲																									lb
																									lb
																									lb
138 ft	11	▶	50	52	59	66	72	79	82	85	88	89	92	98	105	112	118	125	131	138				ft	
▲▲▲																									lb
																									lb
																									lb
110 ft	11	▶		61	66	72	79	82	85	89	92	98	105	108	110										ft
▲▲▲																									lb
																									lb
																									lb

164 ft	11	▶		50	52	59	66	72	79	85	88	92	98	105	112									ft	
▲▲▲																									lb
																									lb
																									lb

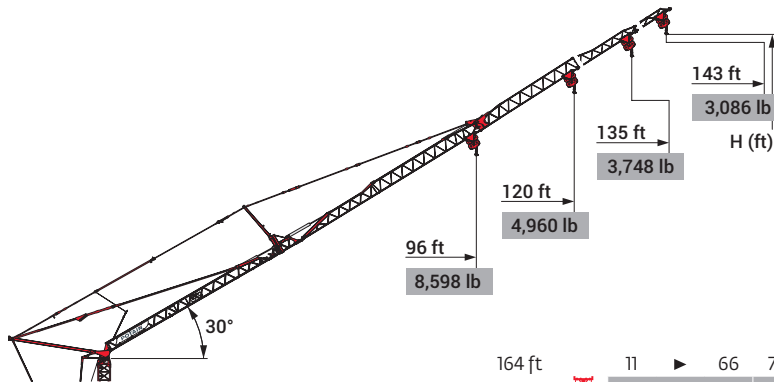

▲▲▲		164 ft	154 ft	138 ft	110 ft
H+3	!	200	195	-	-
H+2	!	190	185	-	-
		180	175	166	151
H+1		171	165	156	141
		161	156	147	132
H+0		151	146	137	122



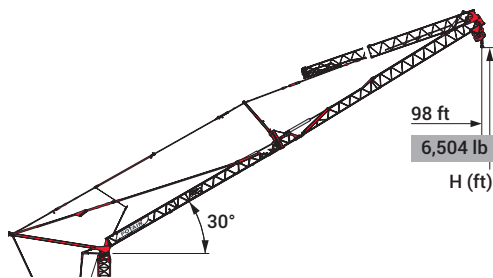



164 ft	11	▶	66	72	79	85	92	98	105	112	118	125	131	138	143	ft
▲▲▲																lb
																lb
																lb
154 ft	11	▶	70	72	79	85	92	98	105	112	118	125	135		ft	
▲▲▲																lb
																lb
																lb
138 ft	11	▶		77	85	92	98	105	112	120					ft	
▲▲▲																lb
																lb
																lb
110 ft	11	▶					94	96							ft	
▲▲▲																lb
																lb







▲▲▲	164 ft
	154 ft
	138 ft
H+2	152
H+1	142
	133
H+0	123

164 ft	11	▶		77	79	85	92	98							ft	
▲▲▲																lb
																lb
																lb

Mechanisms

480 V - 60 Hz												hp	kW	
	<b>33 LVF 20 Optima</b>	fpm	10	52	112	174	207	5	26	56	87	103	29.5	22
		lb	8,818	8,818	8,818	4,409	2,205	17,637	17,637	17,637	8,818	4,409		
	<b>5 DVF 5</b>	fpm	49 - 98 - 128 (4,409 → 17,637 lb) 49 - 98 - 180 (441 → 4,409 lb) 49 - 98 - 230 (0 → 441 lb)									5.4	4	
	<b>RVF 161 Optima+</b>	rpm	0 → 0.8									7.5	5.5	
	<b>TVF 124</b>	fpm	82									2 x 4	2 x 3	

 IEC 60204-32	 kVA
480 V (+6% -10%) 60 Hz	 31 → 19 kVA  35 → 22 kVA 

33 LVF 20 Optima

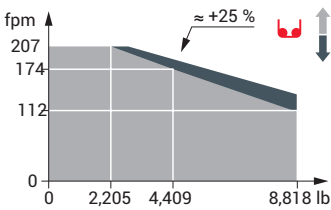

Erection

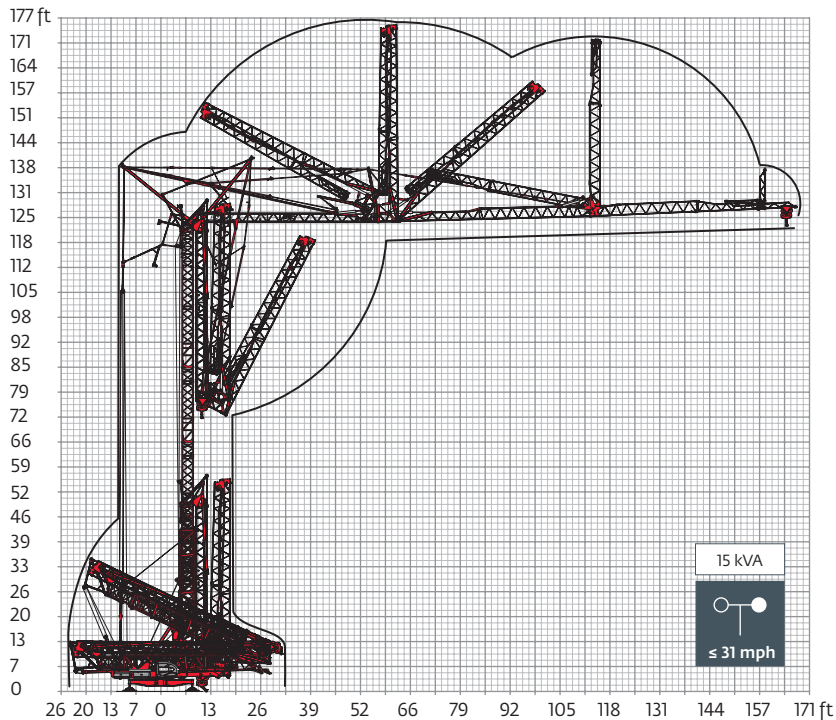

Transport

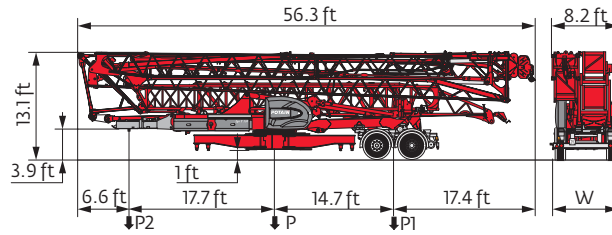

	mph	W (ft)	P (lb)	P1 (lb)	P2 (lb)
SL121/S215M	15.5	7.9	66,359	42,549	23,810

NORTH AMERICAN HIGHWAY AXLE

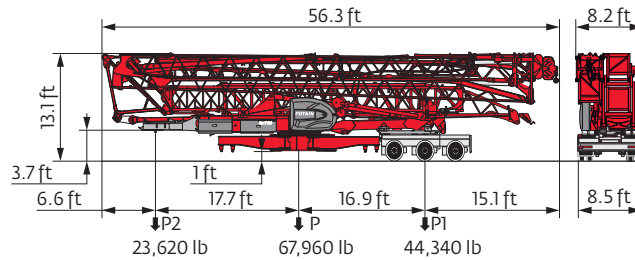

The reactions meet the EN 14439 and ASCE 7-10 specifications for "out of service" wind conditions, provided the illustrated wind speed matches required design wind speed for the location of the tower crane. The "out of service" design wind speed was determined in accordance with ASCE 7-10, Figure 26.5-1A. The wind velocity, used for this configuration was 98 mph (158 kph), which represents a nominal design 3-second wind gust at 33 ft (10 m) above ground for Exposure B category. A factor of 0.85 was applied to the 700-year ultimate design wind speed of 115 mph (185 kph), per ASCE 37-02, with the assumption that this crane is considered a temporary structure used during a construction period of 2 years or less.

- R Rear slewing radius
- ⓘ Consult us
- Reactions in service
- Reactions out of service
- ⚖ Weight without load, without ballast, without transport axles, with max. jib and standard height
- ⚖ Total ballast weight
- Standard equipment
- ⊖ Options
- ⬆ Hoisting
- ⬆ Trolleying
- ⬆ Slewing
- ⬆ Travelling
- kVA Required power
- ⌚ Power Control Function: winch speeds adapted to the available power

⚠ Hook heights given with plated pulley block  
 This commercial document is not legally binding  
 For any technical information, please refer to the corresponding instructions

