

## MRH 175

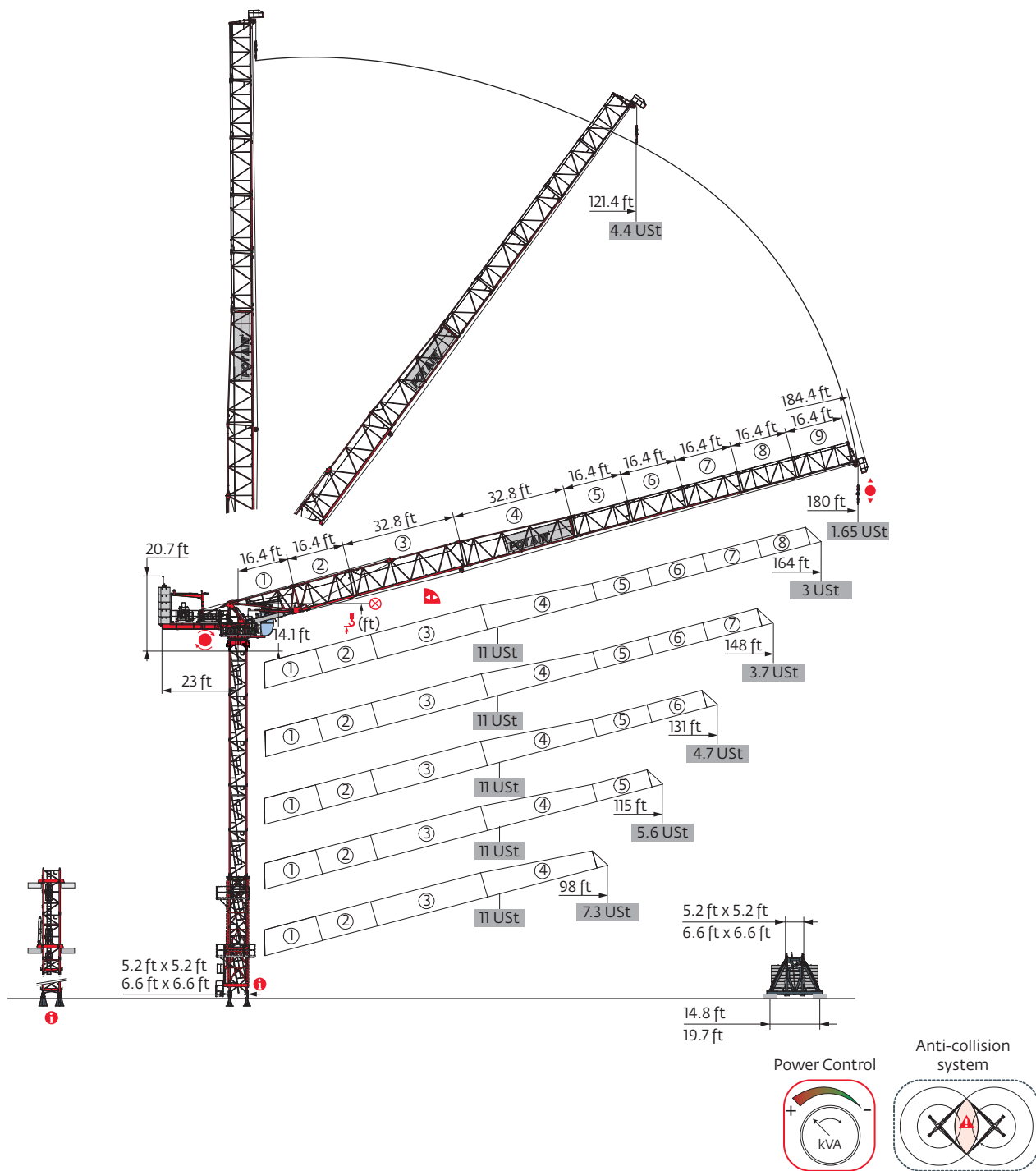

Mast - Reactions

| 5.2 ft - P 42A |       |       |       |       |      |       |  |
|----------------|-------|-------|-------|-------|------|-------|--|
| Height (ft)    | 98    | 115   | 131   | 148   | 164  | 180   |  |
| Height (ft)    | 129.6 | 129.6 | 113.2 | 113.2 | 96.8 | 102.4 |  |
| 10.9 ft        | 0     | 0     | 0     | 0     | 0    | 2     |  |
| 16.4 ft        | 5     | 5     | 4     | 4     | 3    | 2     |  |
| 32.8 ft        | 1     | 1     | 1     | 1     | 1    | 1     |  |
| F2 (Ust)       | ● 164 | 166   | 161   | 168   | 166  | 163   |  |
|                | ■ 169 | 187   | 170   | 188   | 168  | 198   |  |
| F3 (Ust)       | ● 123 | 126   | 116   | 122   | 121  | 125   |  |
|                | ■ 129 | 147   | 130   | 148   | 129  | 159   |  |

| 5.2 ft - S 41A |       |       |       |       |      |      |  |
|----------------|-------|-------|-------|-------|------|------|--|
| Height (ft)    | 98    | 115   | 131   | 148   | 164  | 180  |  |
| Height (ft)    | 129.3 | 123.7 | 107.3 | 107.3 | 90.9 | 96.5 |  |
| 10.9 ft        | 2     | 0     | 0     | 0     | 0    | 2    |  |
| 16.4 ft        | 5     | 6     | 5     | 5     | 4    | 3    |  |
| F1 (Ust)       | ● 97  | 98    | 95    | 99    | 96   | 97   |  |
|                | ■ 93  | 94    | 86    | 94    | 86   | 98   |  |

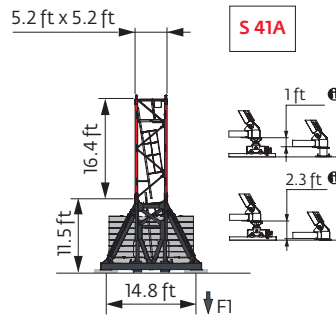
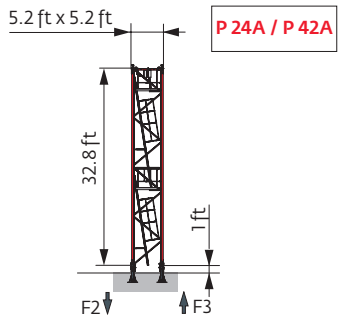

**i** Other mast compositions - Please consult us.

Motorized accesses: adapted mast compositions, base ballast and reactions.

Note: When "ASCE" is noted in this data sheet it is referring to 115 mph Wind Zone, Exposure B, Design Wind Speed = 98 mph. See back cover for design wind speed calculations.

**6.6 ft - P 63A**

| Span (ft)   | 98             | 115        | 131        | 148        | 164        | 180        |
|-------------|----------------|------------|------------|------------|------------|------------|
| Height (ft) | 228            | 222.8      | 211.6      | 206.4      | 200.8      | 195.2      |
| 10.9 ft     | 0              | 1          | 0          | 1          | 2          | 0          |
| 16.4 ft     | 11             | 10         | 10         | 9          | 8          | 9          |
| 32.8 ft     | 1              | 1          | 1          | 1          | 1          | 1          |
| F2 (Ust)    | ● 197<br>■ 405 | 198<br>409 | 197<br>397 | 200<br>401 | 203<br>404 | 191<br>404 |
| F3 (Ust)    | ● 143<br>■ 351 | 139<br>356 | 138<br>344 | 141<br>348 | 145<br>351 | 139<br>351 |

**6.6 ft - V 60A**

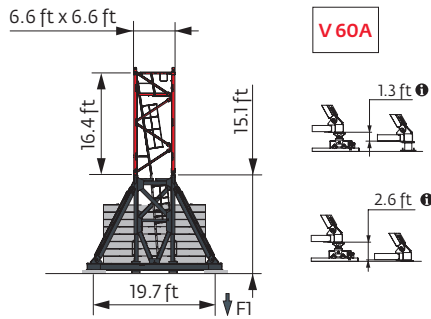
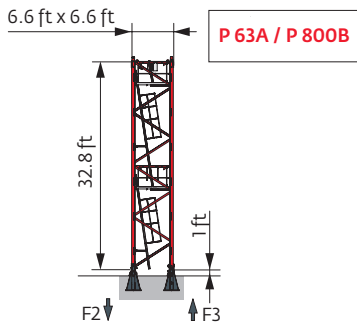

| Span (ft)   | 98             | 115        | 131        | 148        | 164        | 180        |
|-------------|----------------|------------|------------|------------|------------|------------|
| Height (ft) | 182.1          | 176.5      | 165.7      | 160.1      | 149.3      | 143.7      |
| 10.9 ft     | 2              | 0          | 2          | 0          | 2          | 0          |
| 16.4 ft     | 8              | 9          | 7          | 8          | 6          | 7          |
| F1 (Ust)    | ● 105<br>■ 139 | 107<br>140 | 106<br>135 | 107<br>137 | 107<br>131 | 101<br>131 |







Anchorage





Base ballast

 (USt) /  5.2 ft - S 41A - 







|  (ft) | 98    | 115   | 131   | 148   | 164   | 180   |
|--|-------|-------|-------|-------|-------|-------|
| 129.3  | 119.1 |       |       |       |       |       |
| 123.7  | 112.4 | 119.1 |       |       |       |       |
| 107.3  | 105.8 | 105.8 | 112.4 | 119.1 |       |       |
|  (ft) | 96.5  | 99.2  | 99.2  | -     | -     | 125.7 |
| 90.9   | 92.6  | 99.2  | 105.8 | 105.8 | 112.4 | 119.1 |
| 74.5   | 79.4  | 86    | 92.6  | 92.6  | 99.2  | 105.8 |
| 58.1   | 72.8  | 72.8  | 79.4  | 86    | 92.6  | 99.2  |
| 41.7   | 59.5  | 66.1  | 72.8  | 72.8  | 79.4  | 86    |

 (USt) /  6.6 ft - V 60A - 

|  (ft) | 98    | 115   | 131   | 148   | 164   | 180   |
|--|-------|-------|-------|-------|-------|-------|
| 182.1  | 145.5 |       |       |       |       |       |
| 176.5  | 132.3 | 145.5 |       |       |       |       |
| 165.7  | 119.1 | 132.3 | 145.5 |       |       |       |
| 160.1  | 105.8 | 119.1 | 132.3 | 145.5 |       |       |
| 149.3  | 79.4  | 92.6  | 105.8 | 132.3 | 145.5 |       |
|  (ft) | 143.7 | 79.4  | 79.4  | 105.8 | 119.1 | 132.3 |
| 127.3  | 66.1  | 79.4  | 79.4  | 92.6  | 105.8 | 119.1 |
| 110.9  | 66.1  | 66.1  | 66.1  | 79.4  | 79.4  | 79.4  |
| 94.5   | 52.9  | 52.9  | 66.1  | 66.1  | 66.1  | 79.4  |
| 78.1   | 39.7  | 52.9  | 52.9  | 52.9  | 66.1  | 66.1  |
| 61.7   | 39.7  | 39.7  | 39.7  | 52.9  | 52.9  | 52.9  |
| 45.3   | 26.5  | 39.7  | 39.7  | 39.7  | 39.7  | 52.9  |



Load curves









|  (ft)    | 56  | 66            | 72 | 82 | 89 | 98 | 99.5 | 105 | 115 | 115.6   | 121 | 131 | 131.8 | 138 | 148 | 154 | 164 | ft  |     |     |     |
|---|---|---------------|----|----|----|----|------|-----|-----|---|-----|-----|-------|-----|-----|-----|-----|-----|-----|-----|-----|
|  11 USt  |  |               |    |    |    |    |      |     |     |  |     |     |       |     |     |     |     |     |     |     |     |
|  5.5 USt |  |               |    |    |    |    |      |     |     |  |     |     |       |     |     |     |     |     |     |     |     |
| 164   | 15.1 → 73.6   | 114.3 - 116.8 |    | 11 | 11 | 11 | 9.4  | 8.4 | 7.1 | -   | 6.4 | 5.5 | -     | 5.1 | 4.4 | -   | 4   | 3.5 | 3.1 | 2.7 | USt |
| 148   | 14.1 → 73   | 113.5 - 115.9 |    | 11 | 11 | 11 | 9.3  | 8.3 | 7   | -   | 6.3 | 5.5 | -     | 5.1 | 4.4 | -   | 4   | 3.4 | USt |     |     |
| 131   | 13.5 → 73.2   | 114.1 - 116.5 |    | 11 | 11 | 11 | 9.4  | 8.4 | 7.1 | -   | 6.4 | 5.5 | -     | 5.1 | 4.4 | 4.4 | USt |     |     |     |     |
| 115   | 12.5 → 73.6   | 115.6 - 115.6 |    | 11 | 11 | 11 | 9.5  | 8.5 | 7.2 | -   | 6.5 | 5.6 | 5.5   | USt |     |     |     |     |     |     |     |
| 98  | 11.5 → 73.7   |               |    | 11 | 11 | 11 | 9.5  | 8.5 | 7.3 | 7.2   | USt |     |       |     |     |     |     |     |     |     |     |

 =  - 0.21 USt max.

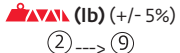

|  (ft)    | 56           | 66 | 72  | 82  | 89  | 98  | 99.5 | 105 | 115 | 115.6 | 121 | 131 | 131.8 | 138 | 148 | 154 | 164 | 171 | 180  | ft   |     |
|---|--------------|----|-----|-----|-----|-----|------|-----|-----|-------|-----|-----|-------|-----|-----|-----|-----|-----|------|------|-----|
|  5.5 USt |              |    |     |     |     |     |      |     |     |       |     |     |       |     |     |     |     |     |      |      |     |
| 180   | 16.1 → 121.4 |    | 4.4 | 4.4 | 4.4 | 4.4 | 4.4  | 4.4 | 4.4 | 4.4   | 4.4 | 4.4 | 3.8   | -   | 3.4 | 2.9 | 2.6 | 2.2 | 1.95 | 1.65 | USt |
| 164   | 15.1 → 120.1 |    | 5.5 | 5.5 | 5.5 | 5.5 | 5.5  | 5.5 | 5.5 | 5.5   | 5.5 | 5.4 | 4.7   | -   | 4.3 | 3.7 | 3.4 | 3   | USt  |      |     |
| 148   | 14.1 → 119.3 |    | 5.5 | 5.5 | 5.5 | 5.5 | 5.5  | 5.5 | 5.5 | 5.5   | 5.5 | 5.3 | 4.7   | -   | 4.2 | 3.7 | USt |     |      |      |     |
| 131   | 13.5 → 120   |    | 5.5 | 5.5 | 5.5 | 5.5 | 5.5  | 5.5 | 5.5 | 5.5   | 5.5 | 5.4 | 4.7   | 4.7 | USt |     |     |     |      |      |     |
| 115   | 12.5 → 115.6 |    | 5.5 | 5.5 | 5.5 | 5.5 | 5.5  | 5.5 | 5.5 | 5.5   | 5.5 | 5.5 | USt   |     |     |     |     |     |      |      |     |
| 98  | 11.5 → 99.5  |    | 5.5 | 5.5 | 5.5 | 5.5 | 5.5  | 5.5 | 5.5 | 5.5   | USt |     |       |     |     |     |     |     |      |      |     |

Jib weight & counter-jib ballast

|   |  (lb) (+/- 5%)<br>② ----> ⑨ |   |  |  |
|---|--|---|---|--|
|  |                             |  | 10,472 lb   |  (lb) |
| 180 ft  | 16,403   | -   | 5   | 52,360   |
| 164 ft  | 15,731   | 16,128  | 5   | 52,360   |
| 148 ft  | 14,948   | 15,345  | 5   | 52,360   |
| 131 ft  | 14,000   | 14,397  | 5   | 52,360   |
| 115 ft  | 12,821   | 13,218  | 5   | 52,360   |
| 98 ft   | 11,465   | 11,862  | 5   | 52,360   |

CCL - 10,472 lb

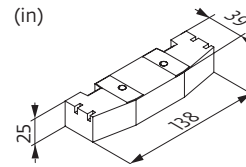



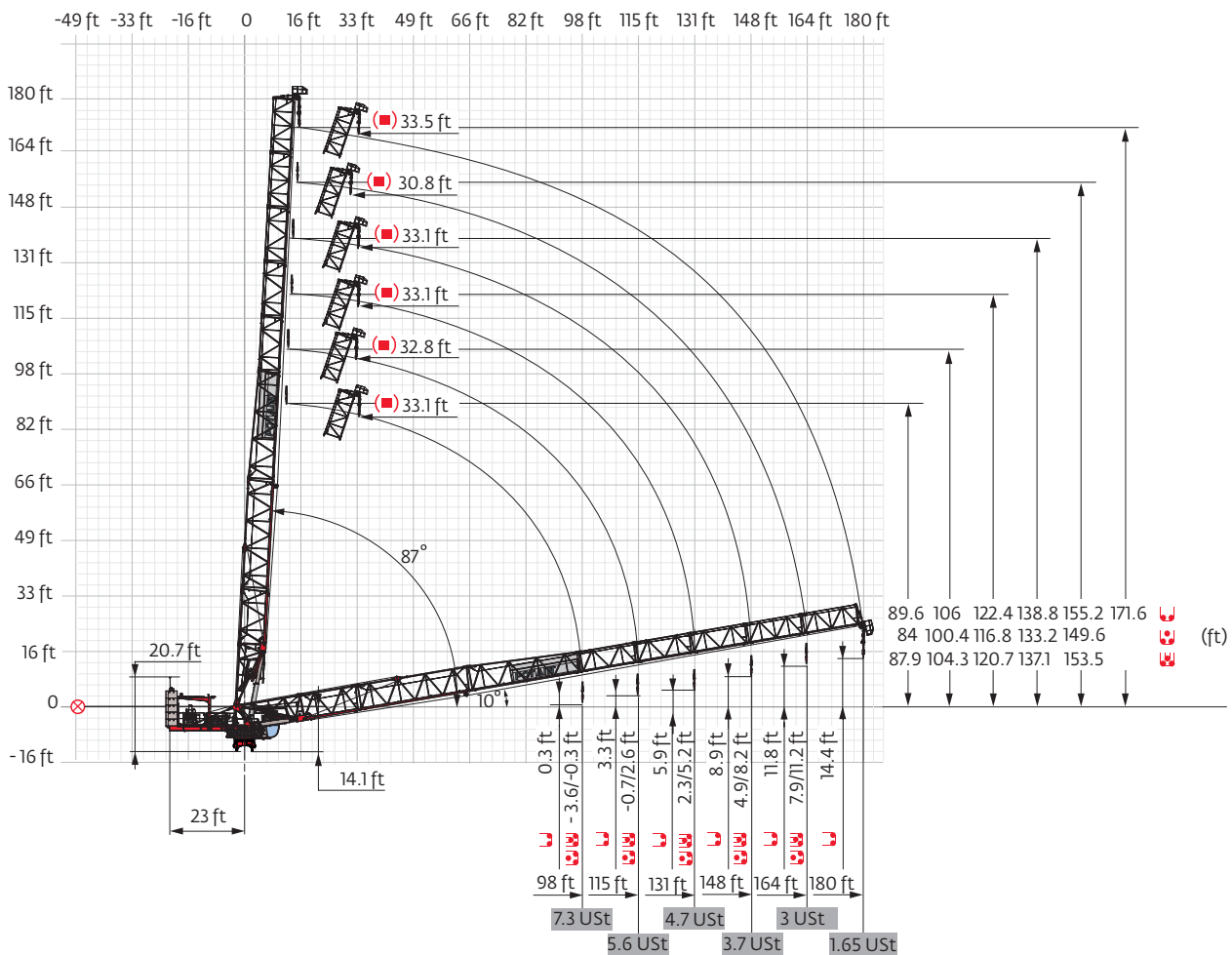





Luffing jib

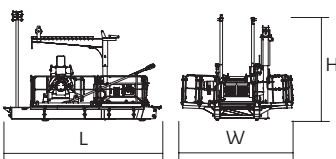
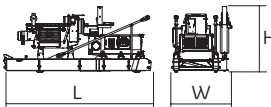
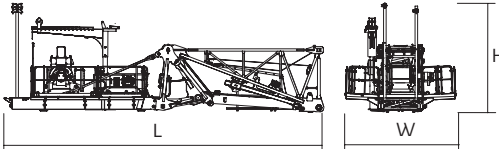
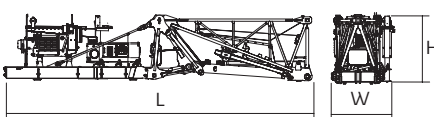

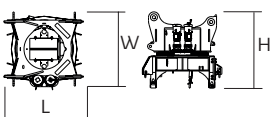
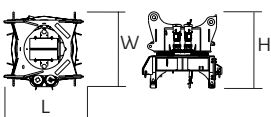
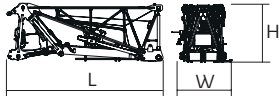
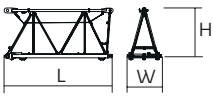
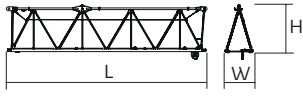
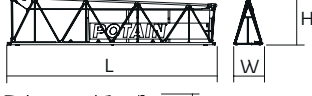



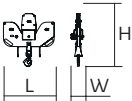
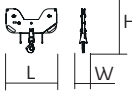

Dimensions and weight

Slewing crane part:  180 ft -  50 LVF

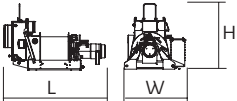

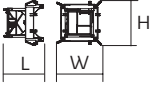
| Slewing crane part     |   | L (ft)            | W (ft) | H (ft) | lb (+/- 5%) |                  |
|------------------------|---|-------------------|--------|--------|-------------|------------------|
| Counter-jib            |    | 50 LVF<br>90 HPL™ | 19.7   | 13.9   | 13.1        | 15,399<br>17,780 |
|                        |    | 50 LVF<br>90 HPL™ | 18.2   | 7.4    | 10          | 14,099<br>16,480 |
| Counter-jib + Jib foot |    | 50 LVF<br>90 HPL™ | 40     | 13.9   | 13.1        | 32,187<br>34,568 |
|                        |   | 50 LVF<br>90 HPL™ | 39.4   | 7.4    | 8.4         | 30,887<br>33,268 |
| Cab                    |  | V140 SR           | 15.9   | 7.8    | 8.2         | 3,748            |
| Towerhead              |  | □ 5.2 ft          | 7.1    | 6.6    | 7.8         | 10,891           |
|                        |  | □ 6.6 ft          | 8.2    | 8.1    | 7.8         | 13,922           |
| Jib section            |  | ①                 | 21.6   | 7.1    | 8.4         | 16,788           |
|                        |  | ②                 | 17.4   | 5.6    | 8.2         | 3,164            |
|                        |  | ③                 | 33     | 4.7    | 8.2         | 4,068            |
|                        |  | ④                 | 33.6   | 4.7    | 7.8         | 3,395            |
|                        |  | ⑤                 | 17.1   | 4.7    | 6.4         | 1,356            |
|                        |  | ⑥                 | 17     | 4.7    | 6.4         | 1,179            |
|                        |  | ⑦                 | 16.9   | 4.7    | 6.4         | 948              |
|                        |  | ⑧                 | 16.9   | 4.5    | 6.3         | 783              |
|                        |  | ⑨                 | 16.9   | 4.5    | 6.3         | 672              |
|                        |  |                   | 4      | 4.9    | 10          | 397              |

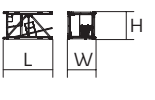
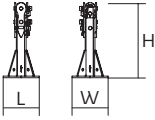
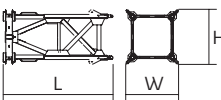
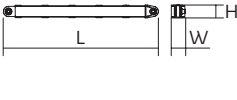
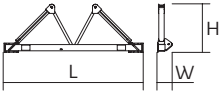
|  |   |   |  |  |  |  |  |
|--|---|---|--|--|--|--|--|
| Pulley block   |    |  |            | 4.8  | 1.2  | 4.9  | 838  |
|  |   |   |             | 4.8  | 0.7  | 4.1  | 441  |
| Hoisting winch (+ rope)  |    |   | 50 LVF<br>90 HPL™  | 8.2<br>9.3   | 5<br>4.3   | 5.3<br>5.6   | 4,365<br>6,746   |
| <b>Crane tower</b>   |   |   |  | <b>L (ft)</b>  | <b>W (ft)</b>  | <b>H (ft)</b>  | <b>lb<br/>(+/- 5%)</b>   |
| T61  |    |   | □ 6.6 ft   | 35.5   | 13.6   | 14.7   | 21,385   |
| K60/K40-2  |    |   | □ 6.6/5.2 ft   | 7.3  | 8.2  | 8.1  | 5,820  |
| K 447E<br>KM 447E<br>KM 449E<br>K 649B<br>KM 649E<br>KRM 6410B                         |   |   | □ 5.2 ft<br>□ 5.2 ft<br>□ 5.2 ft<br>□ 6.6 ft<br>□ 6.6 ft<br>□ 6.6 ft                         | 33.5<br>33.5<br>33.5<br>33.6<br>33.8<br>33.6                 | 5.3<br>5.3<br>5.3<br>6.8<br>6.7<br>6.9               | 5.3<br>5.3<br>5.3<br>6.7<br>6.7<br>6.8               | 7,474<br>7,088<br>8,830<br>11,663<br>10,692<br>15,653                |
| K 447A<br>KMT 447A<br>K 449A<br>KMT 449A<br>KR 649A<br>KRMT 649A<br>K 649A<br>KMT 649A |  |   | □ 5.2 ft<br>□ 5.2 ft<br>□ 5.2 ft<br>□ 5.2 ft<br>□ 6.6 ft<br>□ 6.6 ft<br>□ 6.6 ft<br>□ 6.6 ft | 17.1<br>17.1<br>17.1<br>17.1<br>17.2<br>17.2<br>17.2<br>17.2 | 5.5<br>5.5<br>5.5<br>5.5<br>6.9<br>6.9<br>6.8<br>6.8 | 5.3<br>5.3<br>5.3<br>5.3<br>6.8<br>6.8<br>6.7<br>6.7 | 4,079<br>3,847<br>4,916<br>4,696<br>7,165<br>6,724<br>6,184<br>5,666 |
| K 447C<br>KMT 447C<br>K 649C<br>KMT 649C<br>KRMT 649C                                  |  |   | □ 5.2 ft<br>□ 5.2 ft<br>□ 6.6 ft<br>□ 6.6 ft<br>□ 6.6 ft                                     | 11.3<br>11.6<br>11.7<br>11.7<br>11.7                         | 5.5<br>5.5<br>6.8<br>6.8<br>6.9                      | 5.3<br>5.3<br>6.7<br>6.7<br>6.8                      | 2,998<br>2,976<br>4,559<br>4,542<br>5,401                            |
| Fixing angles  |  |   | P 24A / P 42A<br>P 63A / P 800B  | 1.8<br>2.5   | 1.8<br>2.5   | 3.8<br>4.2   | 529<br>1,025   |
| Basic mast unit  |  |   | S 41A<br>V 60A   | 11.9<br>16.4   | 6.4<br>7.9   | 6.8<br>7.9   | 7,132<br>10,494  |
| Struts   |  |   | S 41A<br>V 60A   | 10.4<br>14.8   | 0.9<br>1   | 0.8<br>1   | 816<br>1,036   |
| Half-bearer  |  |   | S 41A<br>V 60A   | 16.7<br>22   | 2<br>2.3   | 5.8<br>7.6   | 2,315<br>4,057   |

Mechanisms

| 480 V - 60 Hz |                         |     |         |     |     |     |     |     |     | hp  | kW      |       |          |    |          |
|---------------|-------------------------|-----|---------|-----|-----|-----|-----|-----|-----|-----|---------|-------|----------|----|----------|
|               | <b>50 LVF 25 Optima</b> | fpm | 126     | 166 | 221 | 313 | 66  | 85  | 115 | 157 | 50      | 37    | 1,827 ft |    |          |
|               |                         | USt | 5.5     | 4.1 | 2.8 | 1.1 | 11  | 8.3 | 5.5 | 2.5 |         |       |          |    |          |
|               | <b>90 HPL™ 25</b>       | fpm | 213     | 279 | 392 | 518 | 707 | 110 | 146 | 203 | 271     | 353   | 90       | 66 | 3,136 ft |
|               |                         | USt | 5.5     | 4.1 | 2.8 | 1.4 | 0.4 | 11  | 8.3 | 5.5 | 2.8     | 1.3   |          |    |          |
|               | <b>60 VVH 140</b>       | min | 2       |     |     |     |     |     |     |     | 60      | 45    |          |    |          |
|               | <b>RVF 152 Optima +</b> | rpm | 0 → 0.8 |     |     |     |     |     |     |     | 2 x 5.5 | 2 x 4 |          |    |          |
|               |                         |     |         |     |     |     |     |     |     |     |         |       |          |    |          |

|                        | <b>IEC 60204-32</b>                       | <b>kVA</b> |
|------------------------|---|------------|
| 480 V (+6% -10%) 60 Hz | 50 LVF: 107 kVA<br>90 HPL™: 139 → 103 kVA |            |

50 LVF 25 Optima

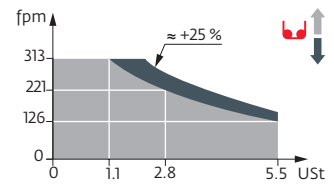

These mast combinations meet the EN 14439 and ASME B30.3-2016 specifications for "out of service" wind conditions, provided the illustrated wind speed matches required design wind speed for the location of the tower crane. The "out of service" design wind speed was determined in accordance with ASCE 7-10, Figure 26.5-1A. The wind velocity, used for this configuration was 98 mph (158 kph), which represents a nominal design 3-second wind gust at 33 ft (10 m) above ground for Exposure B category. A factor of 0.85 was applied to the 700-year ultimate design wind speed of 115 mph (185 kph), per ASCE 37-02, with the assumption that this crane is considered a temporary structure used during a construction period of 2 years or less.

- Standard equipment
- Options
- Reactions in service
- Reactions out of service
- Jib weight
- Total ballast weight
- Jib articulation axis
- Weathering position
- Lorry 44 ft
- Container High Cube 40 ft, and/or Flat Rack 20 ft
- Hoisting
- Luffing
- Slewing
- Travelling
- Required power
- Power Control Function: winch speeds adapted to the available power
- Consult us

This commercial document is not legally binding. For any technical information, please refer to the corresponding instructions.

