

MCR 295 H16/H20/H25

Potain Center of Excellence Design

Maximum capacity:	16 t, 20 t, 25 t
Maximum operating hook radius:	60 m
Maximum capacity at 60 m:	2.8 t (H16), 2.7 t (H20), 2.45 t (H25)
Maximum line speed:	117 m/min (H16) 245 m/min (H20) 191 m/min (H25)



Vision cab

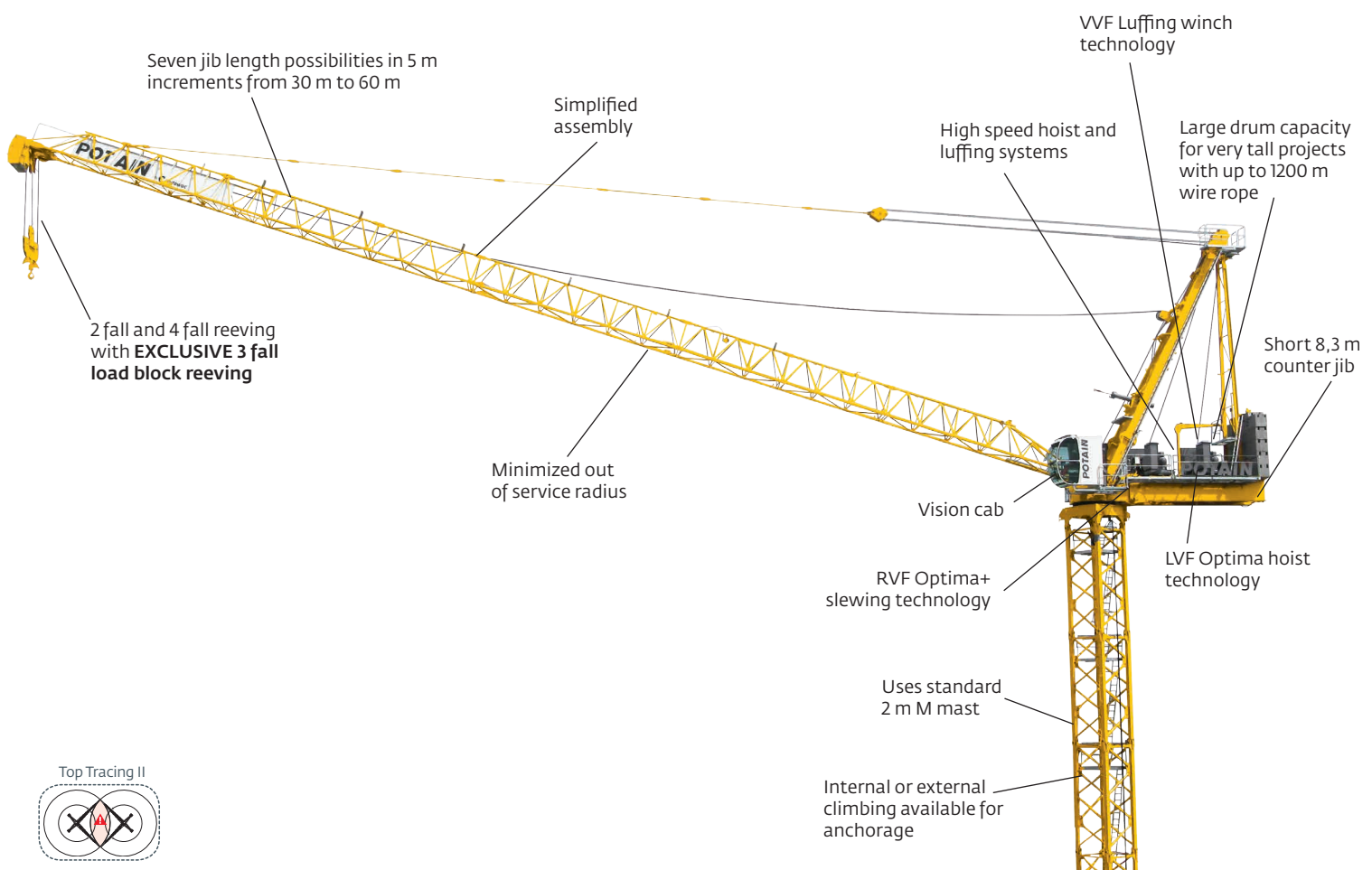

SMART AND COMPACT DESIGN SPECIALLY ADAPTED TO HIGH, CRAMPED OR VERY OBSTRUCTED SITES.

Operational compact dimensions

- Optimized counter jib length 8.3 m
- Minimized out of service radius 18 m - 22 m
- 2.9 m to 5 m minimum radius in service

Optimal packaging for reduced shipping costs

- Minimized component dimensions for easy transportation
- Complete transport in containers, 6 HC 40' only for the entire slewing crane part with 60 m jib

Simple and safe erection

- Minimized weight of components for simplified assembly
- Simplified mounting of the jib foot with notches on the slewing towerhead
- Easy jib tie bar erection thanks to the standard auxiliary winch
- Rapid pin-connection of the counter-jib

POTAIN CENTER OF EXCELLENCE DESIGN MAXIMIZES YOUR PRODUCTIVITY

High productivity

- Smooth movements due to frequency control Technology
- Powerful hoisting winches (75 hp - 150/180 hp) make the MCR 295 ideal for jobsites with pre-cast or heavy loads :
 - > Maximum hoisting speeds from 90 m/min up to 245 m/min.
 - > Large drum capacity for very tall projects
 - > Optimized speed depending on the load
 - > Power Control function available on the 150/180 hp winch for reduced electrical demand

LVF Optima Technology

- Extremely accurate and reactive luffing movements through VVF technology, 1 min 40s only to completely raise the jib
- Standard 2/3/4 fall reeving
- Optimized load curves can be achieved with unique 3-fall rope reeving,
- Vision cab with Dialog VISU indicators, user-friendly operating cab with exceptional visibility on jobsite

VVF luffing system

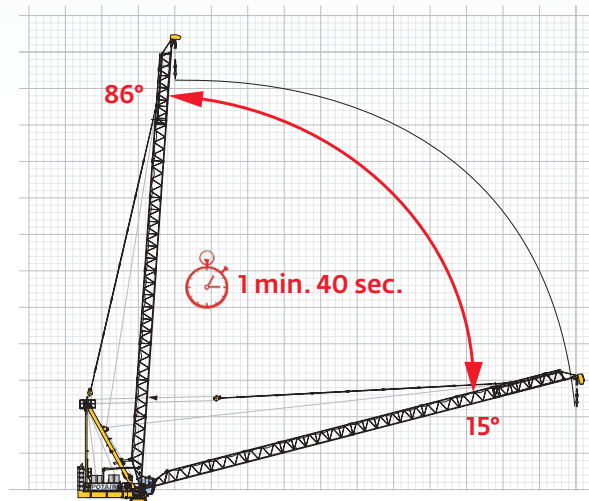

RVF Optima+ slewing system

- Slewing speeds up to 0.8 rpm

Wide range of equipment For more comfort for driving, erecting and maintenance

- Standard: Automatic internal slewing ring greasing (cartridges)
- Luffing winch equipped with a safety brake on the drum
- Optional: Anemometer and Top Tracing II, and Air-conditioned cab

LIFTING HOIST PERFORMANCE						
	16 t version		20 t version		25 t version	
	75 LVF 40 Optima	100 LVF 40 Optima	100 LVF 50 Optima	150/180 LVF 50 Optima	100 LVF 63 Optima	150/180 LVF 63 Optima
Max hoisting speed	90 m/min with 2 t	117 m/min with 2 t	94 m/min with 2.5 t	245 m/min with 0.8 t	78 m/min with 2.7 t	191 m/min with 1.6 t
Drum spooling capacity	637 m	1136 m	1018 m	1200 m	726 m	1200 m

