

MRH 125

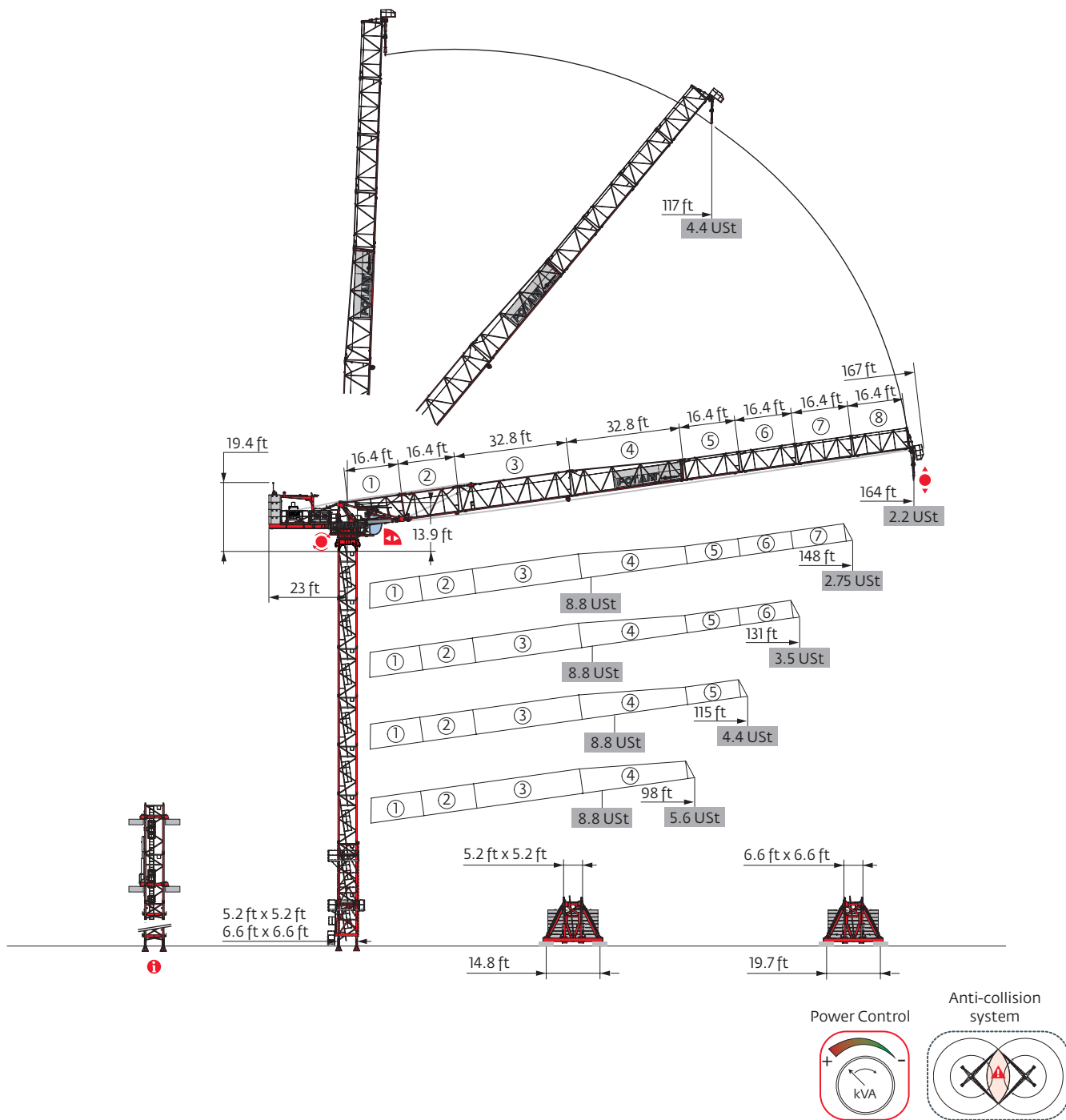

Mast - Reactions

5.2 ft - P 41A					
Height (ft)	98	115	131	148	164
Height (ft)	157.2	146	140.8	129.6	124.3
10.9 ft	1	0	1	0	1
16.4 ft	8	8	7	7	6
F2 (Ust)	● 152	149	149	146	146
	■ 221	213	219	210	215
F3 (Ust)	● 115	113	113	111	111
	■ 184	177	184	175	181

5.2 ft - S 41A					
Height (ft)	98	115	131	148	164
Height (ft)	145.7	140.1	129.3	118.1	112.9
10.9 ft	2	0	2	1	2
16.4 ft	6	7	5	5	4
F1 (Ust)	● 90	92	91	89	89
	■ 107	110	107	102	105

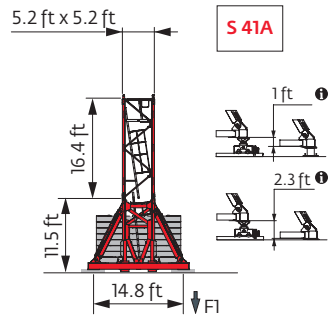
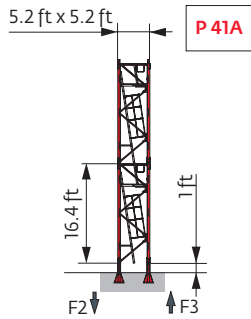

i Motorized accesses: adapted mast compositions, base ballast and reactions.

Note: When "ASCE" is noted in this data sheet it is referring to 115 mph Wind Zone, Exposure B, Design Wind Speed = 98 mph. See back cover for design wind speed calculations.

6.6 ft - P 602B					
Span (ft)	98	115	131	148	164
r_s (ft)	211.6	206.4	200.8	195.2	190
10.9 ft	0	1	2	0	1
16.4 ft	12	11	10	11	10
F2 (Ust)	● 163 ■ 339	163 344	163 347	162 348	161 350
F3 (Ust)	● 117 ■ 293	117 298	117 301	113 302	116 305

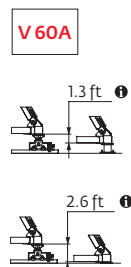
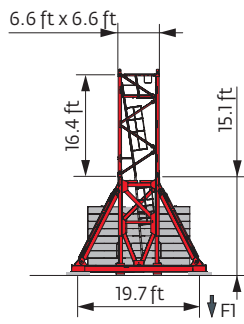
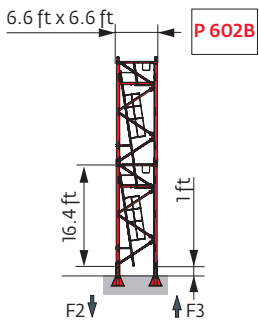

6.6 ft - V 60A -					
Span (ft)	98	115	131	148	164
r_s (ft)	182.1	171.3	165.7	154.9	149.3
10.9 ft	2	1	2	1	2
16.4 ft	8	8	7	7	6
F1 (Ust)	● 97 ■ 137	96 131	96 133	95 126	93 128





Anchorage



Base ballast

 (USt) / 5.2 ft - S 41A - 

ft	98	115	131	148	164
145.7	119.1				
140.1	105.8	125.7			
129.3	86	105.8	125.7		
118.1	79.4	86	105.8	119.1	
112.9	79.4	86	92.6	112.4	125.7
96.5	72.8	72.8	79.4	86	92.6
80.1	59.5	66.1	72.8	72.8	79.4
63.7	52.9	59.5	59.5	66.1	72.8
47.3	46.3	52.9	52.9	59.5	59.5

 (USt) / 6.6 ft - V 60A - 

ft	98	115	131	148	164
182.1	145.5				
171.3	132.3	145.5			
165.7	119.1	132.3	145.5		
154.9	92.6	119.1	132.3	145.5	
149.3	92.6	105.8	119.1	132.3	145.5
132.9	66.1	79.4	92.6	105.8	119.1
116.5	39.7	52.9	66.1	79.4	92.6
100.1	39.7	39.7	39.7	52.9	66.1
83.7	26.5	39.7	39.7	39.7	39.7
67.3	26.5	26.5	26.5	39.7	39.7
50.9	26.5	26.5	26.5	26.5	26.5

Load curves



ft	56	66	72	82	89	98	98.9	105	115	115.2	121	131	131.4	138	148	ft
148	8.8	8.8	8.6	7.1	6.3	5.3	-	4.8	4.2	-	3.8	3.2	-	2.9	2.5	USt
131	8.8	8.8	8.6	7.1	6.3	5.3	-	4.8	4.2	-	3.8	3.3	3.3			USt
115	8.8	8.8	8.8	7.6	6.8	5.7	-	5.2	4.4	4.4	USt					
98	8.8	8.8	8.8	7.3	6.5	5.6	5.5	USt								

 =  - 0.16 USt max.



ft	56	66	72	82	89	98	98.9	105	115	115.2	121	131	131.4	138	148	154	164	ft
164	4.4	4.4	4.4	4.4	4.4	4.4	4.4	4.4	4.4	4.4	4.1	3.6	-	3.2	2.8	2.55	2.2	USt
148	4.4	4.4	4.4	4.4	4.4	4.4	4.4	4.4	4.4	4.4	4	3.5	-	3.2	2.75			USt
131	4.4	4.4	4.4	4.4	4.4	4.4	4.4	4.4	4.4	4.4	4.1	3.5	3.5	USt				
115	4.4	4.4	4.4	4.4	4.4	4.4	4.4	4.4	4.4	4.4	USt							
98	4.4	4.4	4.4	4.4	4.4	4.4	4.4	USt										

Jib weight & counter-jib ballast

Height (ft)	Jib Weight (lb) (+/- 5%)		Counter-jib Ballast (lb)	Total Weight (lb)
	②	⑧		
164 ft	12,887	-	4	41,888
148 ft	12,215	12,612	4	41,888
131 ft	11,432	11,829	4	41,888
115 ft	10,561	10,958	4	41,888
98 ft	9,514	9,911	4	41,888

CCL - 10,472 lb

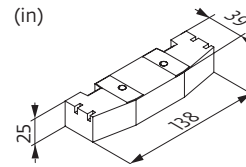



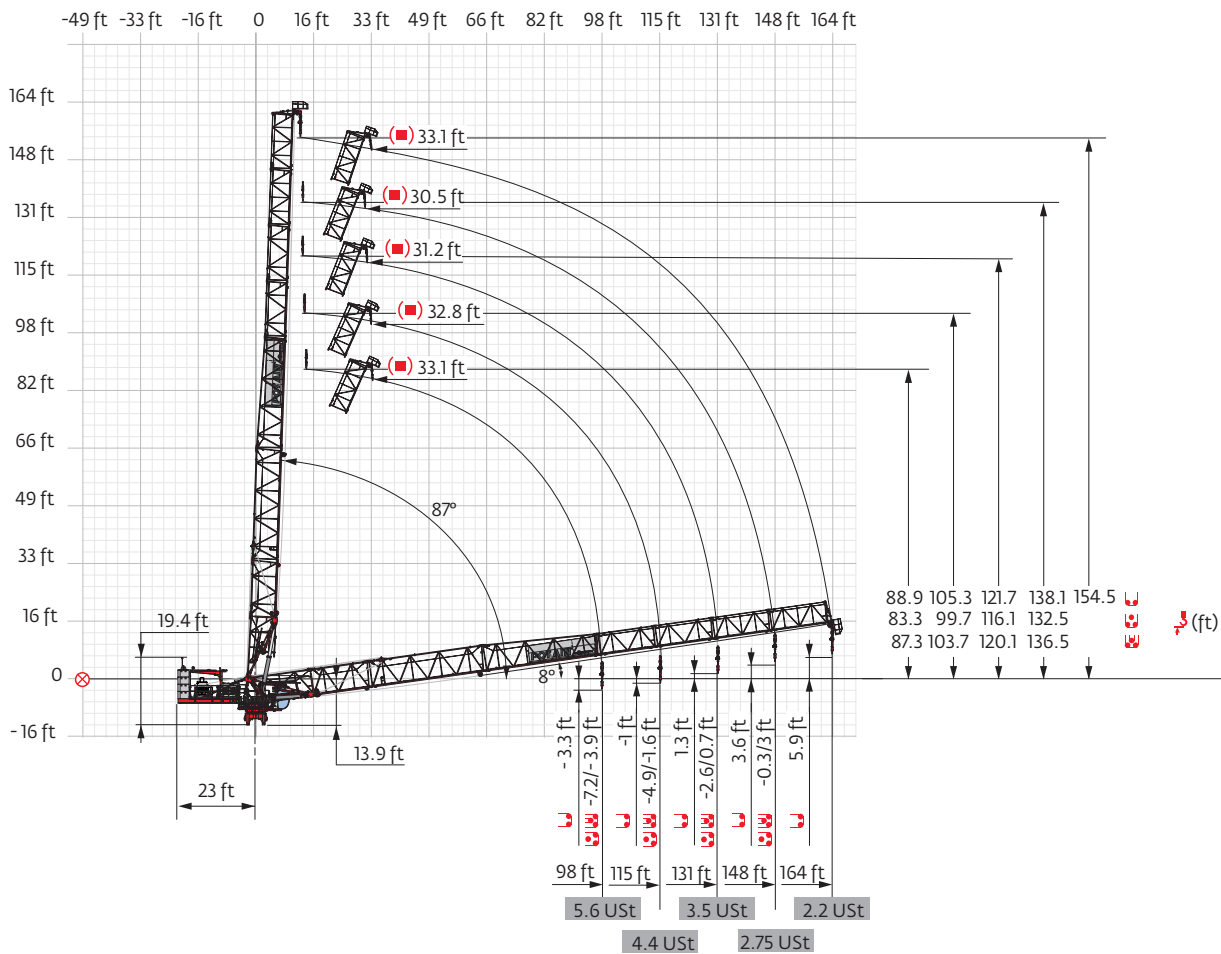





Luffing jib

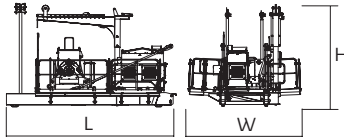
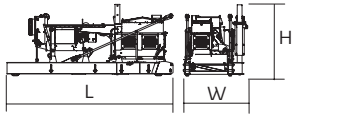
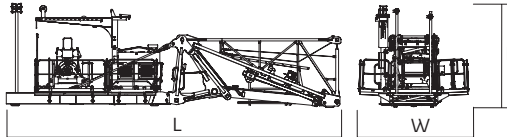
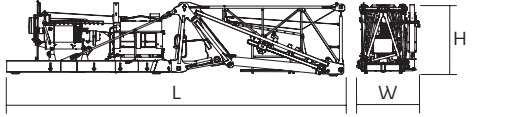
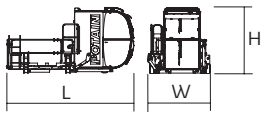
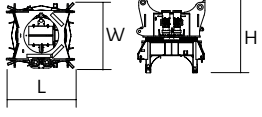

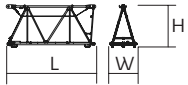
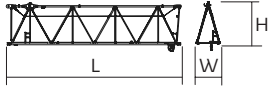

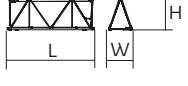





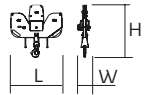

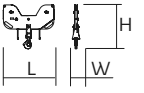
Dimensions and weight

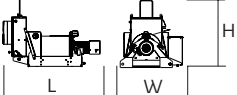
Slewing crane part:  164 ft -  33 LVF

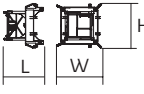

Slewing crane part		L (ft)	W (ft)	H (ft)	lb (+/- 5%)	
Counter-jib		33 LVF 50 LVF	19.3	12.9	11.6	12,721 13,735
		33 LVF 50 LVF	19	7.4	8.2	11,707 12,721
Counter-jib + Jib foot		33 LVF 50 LVF	38.9	12.9	11.6	25,728 26,742
		33 LVF 50 LVF	38.9	7.4	8.4	24,714 25,728
Cab		V140 SR	15.9	7.8	8.2	3,748
Towerhead		□ 5.2 ft □ 6.6 ft	7.1 7.6	6.8 7.8	7.7 7.7	10,362 12,710
Jib section		①	20.5	6.8	8.4	13,007
		②	17.2	5.2	8.3	2,172
		③	33.6	4.7	8.2	3,208
		④	33.5	4.7	7.8	3,296
		⑤	17	4.7	6.4	1,047
		⑥	16.9	4.6	6.3	871
		⑦	16.9	4.5	6.3	783
		⑧	16.9	4.5	6.3	672
			4	4.9	10	397

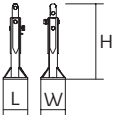
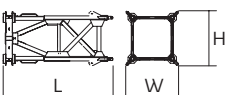
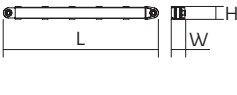
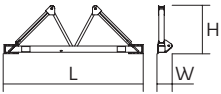
Pulley block			4.8	1.2	4.9	838
			4.8	0.7	4.1	441
Hoisting winch (+ rope)		33 LVF 50 LVF	7.7 8.2	5 5	5.3 5.3	3,428 4,442
Crane tower			L (ft)	W (ft)	H (ft)	lb (+/- 5%)
T41 T61		▽ 5.2 ft ▽ 6.6 ft	35.6 35.5	12.3 13.6	13.5 14.7	15,653 21,385
K60/K40-2		▽ 6.6/5.2 ft	7.3	8.2	8.1	5,820
K 447E KM 447E KM 449E K 649B KM 649E		▽ 5.2 ft ▽ 5.2 ft ▽ 5.2 ft ▽ 6.6 ft ▽ 6.6 ft	33.5 33.5 33.5 33.6 33.8	5.3 5.3 5.3 6.8 6.7	5.3 5.3 5.3 6.7 6.7	7,474 7,088 8,448 11,663 10,692
K 447A KMT 447A K 449A KMT 449A KR 649A KRMT 649A K 649A KMT 649A		▽ 5.2 ft ▽ 5.2 ft ▽ 5.2 ft ▽ 5.2 ft ▽ 6.6 ft ▽ 6.6 ft ▽ 6.6 ft ▽ 6.6 ft	17.1 17.1 17.1 17.1 17.2 17.2 17.2 17.2	5.5 5.5 5.5 5.5 6.9 6.9 6.8 6.8	5.3 5.3 5.3 5.3 6.8 6.8 6.7 6.7	4,079 3,847 4,916 4,696 7,165 6,724 6,184 5,666
K 447C K 649C KMT 649C KRMT 649C		▽ 5.2 ft ▽ 6.6 ft ▽ 6.6 ft ▽ 6.6 ft	11.3 11.7 11.7 11.7	5.5 6.8 6.8 6.9	5.3 6.7 6.7 6.8	2,998 4,376 4,542 5,401
Fixing angles		P 41A P 602B	1.2 2.1	1.2 2.1	3.7 4.2	293 650
Basic mast unit		S 41A V 60A	11.9 16.4	6.4 7.9	6.8 7.9	6,537 9,674
Struts		S 41A V 60A	10.4 14.8	0.9 1	0.8 1	489 919
Half-bearer		S 41A V 60A	16.7 22	2 2.3	5.8 7.6	2,524 3,519

Mechanisms

480 V - 60 Hz											hp	kW	
	33 LVF 20 Optima	fpm	85	112	164	233	43	56	82	116	33	22	1539 ft
		USt	4.4	3.3	2.2	1.1	8.8	6.6	4.4	2.2			
	50 LVF 20 Optima	fpm	144	190	269	387	72	95	135	194	50	37	2287 ft
		USt	4.4	3.3	2.2	1.1	8.8	6.6	4.4	2.2			
	40 VVH 80	min	2							40	30		
	RVF 152 Optima +	rpm	0 → 0.8							2 x 5.5	2 x 4		

	IEC 60204-32		kVA
	480 V (+6% -10%) 60 Hz		33 LVF : 74 → 61 kVA 50 LVF : 88 kVA

33 LVF 20 Optima

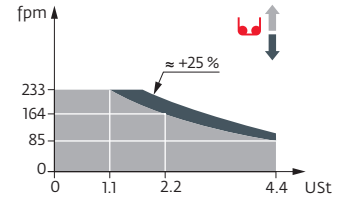

50 LVF 20 Optima

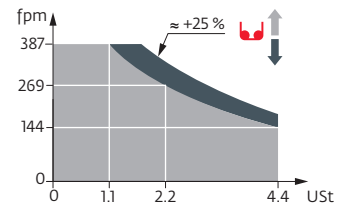

These most combinations meet the EN 14439 and ASME B30.3-2016 specifications for "out of service" wind conditions, provided the illustrated wind speed matches required design wind speed for the location of the tower crane. The "out of service" design wind speed was determined in accordance with ASCE 7-10, Figure 26.5-1A. The wind velocity, used for this configuration was 98 mph (158 kph), which represents a nominal design 3-second wind gust at 33 ft (10 m) above ground for Exposure B category. A factor of 0.85 was applied to the 700-year ultimate design wind speed of 115 mph (185 kph), per ASCE 37-02, with the assumption that this crane is considered a temporary structure used during a construction period of 2 years or less.

- Standard equipment
- Weathering position
- Required power
- Options
- Lorry 44 ft
- Power Control Function: winch speeds adapted to the available power
- Reactions in service
- Container High Cube 40 ft, and/or Flat Rack 20 ft
- Reactions out of service
- Hoisting
- Consult us
- Jib weight
- Luffing
- Total ballast weight
- Slewing
- Jib articulation axis
- Travelling

This commercial document is not legally binding. For any technical information, please refer to the corresponding instructions.

