

SHUTTLELIFT®

SCD15

Product Guide

ASME B30.5 Imperial 85%, Metric 85%



15 USt
(13,6 t)



41 ft - 50 ft
(12,5 m - 15,4 m)

GVW

25,223 lbs
(11 441kg)



69.5 ft
(21,9 m)

SHUTTLELIFT SCD15

FEATURES

Designed with operator productivity and comfort in mind, the SCD15 offers the features and performance that make this carrydeck crane a winner on the jobsite.

- 9 USt (8,1 t) deck carrying ability
- Load sensing hydraulic piston pump
- Mechanical lever proportional controls
- Dual fuel and diesel engine options available. EPA Tier 4 Final emissions compliant without the use of a SCR or UREA injected DEF system.
- Full LED lighting package



Pivoting Boom Nose

Ideal for operating in confined spaces, the three-position mechanically offset (0°, 40° and 80°) pivoting boom nose lowers boom nose head height by 14 in (0,36 m).

Available Options

- 17.3 ft – 50 ft (5,3 m – 15,2 m)
4-section, full-power main boom
- 15 ft (4,6 m) fixed swingaway extension
- **Convenience package:** pintle hitches, light grilles
- **Lighting package:** amber strobe light, boom-mounted work lights
- Below-deck winch
- Air-conditioning

Operator Cab

Simple operator cab features direct-to-valve hydraulic controls, ergonomically laid out fixed steering wheel, and easy-to-set up graphical Rated Capacity Limiter (RCL) system. The cab is up to 4.8" wider providing additional operator comfort. The optional enclosed cab includes split cab door with sliding glass window.



CUSTOMIZED OPTIONS

Standard options may not always meet the job requirements. Consult your local dealer for a Lift Solution quote for customized options, such as:

- Non-marking tires
- Barge charts
- Spark arrestor

Storage Solutions

A storage tray and main storage box are located in the front center of the carrier and are suitable for storing the downhaul ball or hook blocks available on this model. Stow rigging equipment in a storage box located on the right hand side of the machine. This compartment has a latched door to prevent accidental opening when machine is in operation.



The world's most advanced crane service and support network

WORLDWIDE SUPPORT NETWORK

Manitowoc's customer service extends beyond any borders. Our locations span the globe, covering five continents. No matter where the job takes you, you have a business partner nearby.



PARTS

Locating the correct part quickly is vital to managing your operations. With Manitowoc Customer Support, the parts you need are just a phone call or click away.

LIFT SOLUTIONS

The Manitowoc Crane Lift Solutions Team is dedicated to helping customers with unique and customized applications for their Manitowoc cranes, regardless of product line.

TRAINING

Manitowoc Training Centers offer courses for operators and technicians across the globe to provide in-depth instruction on crane operation, maintenance, and troubleshooting procedures.

EnCORE

Manitowoc's EnCORE program maximizes your investment by rebuilding or repairing your crane to extend its life significantly. EnCORE also includes remanufactured parts.



MANITOWOC FINANCE

Manitowoc Finance gets you in the field with the right equipment by giving you access to flexible, affordable financing. With Manitowoc Finance, equipment can be acquired with virtually no cash outlay, and unlike traditional lending, our financial products don't affect bank lines of credit. Your capital resources remain intact for times when you need ready access to cash.

Competitive rates with flexible financing options and payment schedules put you in control.

Did you know? Manitowoc Finance can finance **used** Manitowoc cranes. You can also **trade-in** your used fleet for upgrade and get financed by Manitowoc Finance.





CONTENTS

8

Dimensions and Weights

10

Working Range and Load Charts - 41 ft Boom (Imperial 85%)

14

Working Range and Load Charts - 50 ft Boom (Imperial 85%)

18

Working Range and Load Charts - 12,5 m Boom (Metric 85%)

22

Working Range and Load Charts - 15,2 m Boom (Metric 85%)

26

Transportation and Lifting

27

Load Handling

28

Specifications

31

Symbols Glossary

DIMENSIONS AND WEIGHTS

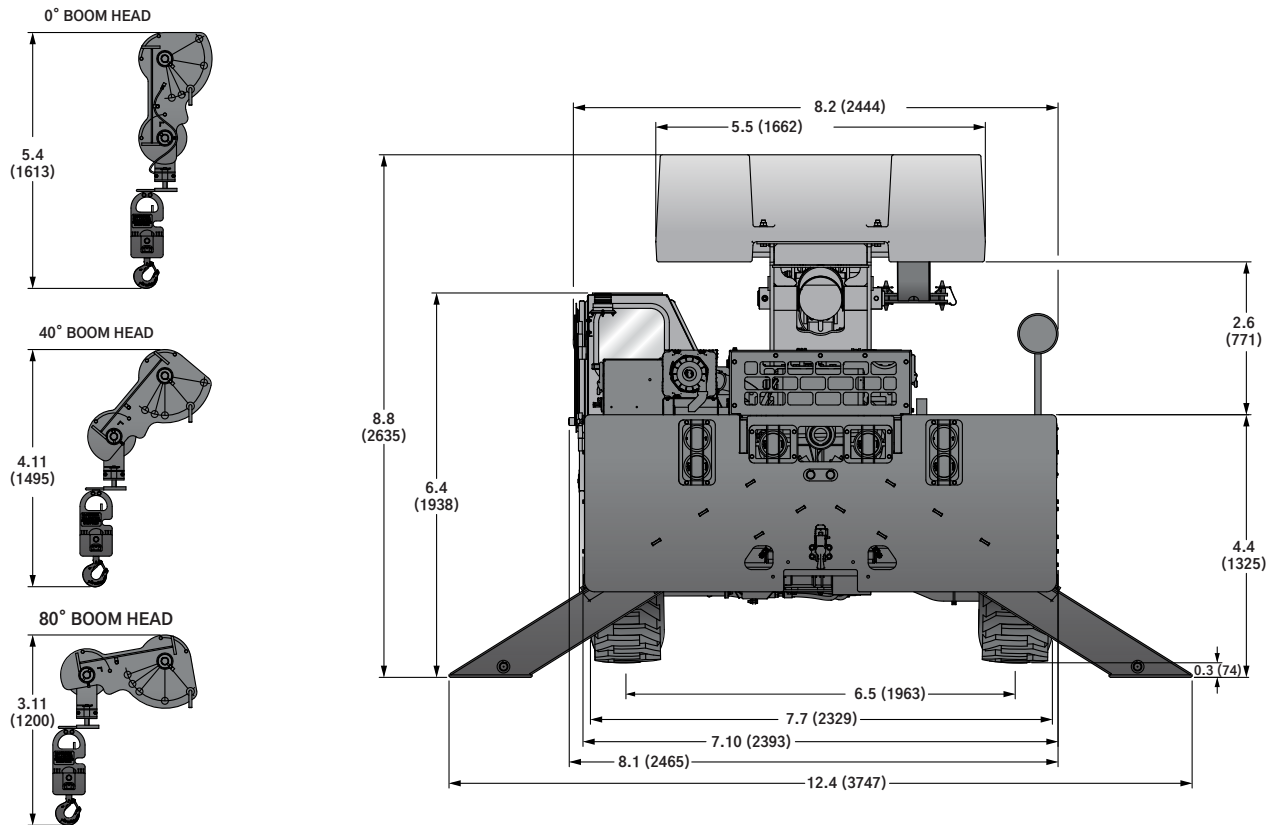

Weights	GVW		Front		Rear	
	kg	lb	kg	lb	kg	lb
Basic machine: including 41.0 ft (12,5 m) main boom, hoist with 235 ft (72 m) of wire rope, 20 USt (18 t) hook block, counterweight, Tier 4 engine, and driver.	11 489	25,329	5328	11,747	6161	13,582
Add: 15 ft (4,6 m) fixed swingaway extension and extension carrier brackets and downhaul weight.	245	540	375	828	-130	-287
Crane Weight	11 734	25,869	5704	12,574	6030	13,295
Basic machine: including 41.0 ft (12,5 m) main boom, main hoist with 235 ft (72 m) of wire rope, 20 USt (18 t) hook block, full counterweight, Tier 4 engine, and driver.	11 489	25,329	5328	11,747	6161	13,582
Add: Enclosed cab with heater and defroster.	89	196	41	90	48	106
Crane Weight	11 578	25,525	5369	11,838	6209	13,687

WORKING RANGE

41 ft Boom - Imperial 85%

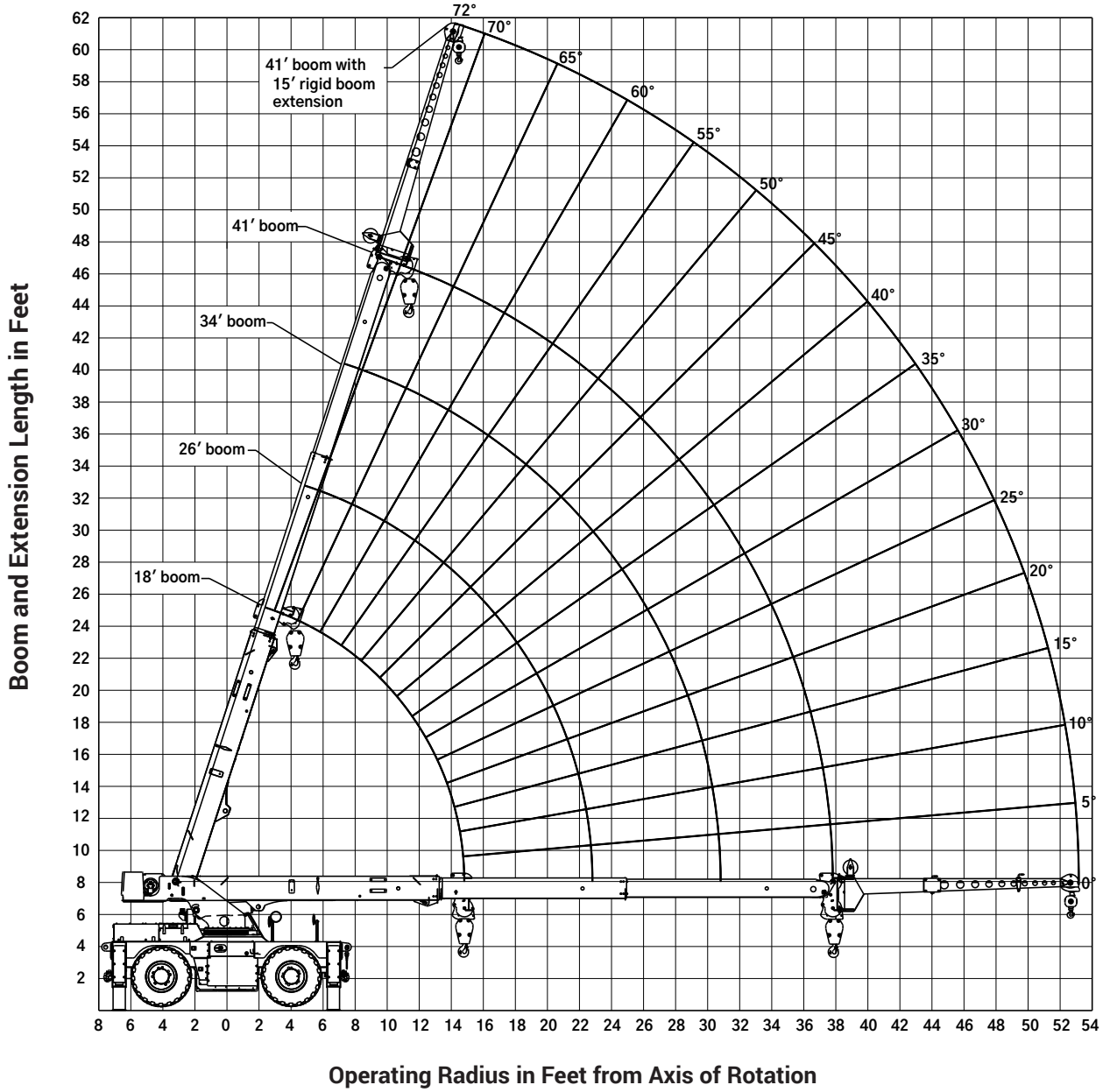

THIS CHART IS ONLY A GUIDE AND SHOULD NOT BE USED TO OPERATE THE CRANE.
The individual crane's load chart, operating instructions and other instructional plates must be read and understood prior to operating the crane

LOAD CHART

41 ft Boom - Imperial 85%



18 ft - 41 ft



100%



360°



18 ft - 41 ft



100%



Over front



Pounds

Feet	Main Boom Length in Feet			
	18	26	34	41
6	30,000 (66)			
8	27,150 (58.5)	19,800 (69.5)		
10	24,000 (50)	19,800 (64.5)		
12	21,500 (39.5)	18,950 (59.5)	17,350 (67.5)	
14	16,000 (24.5)	16,300 (53.5)	15,150 (64)	13,550 (69)
14.5	13,800 (0)	15,300 (52)	14,750 (63)	13,200 (68)
16		12,850 (47.5)	12,750 (60)	12,200 (66)
18		10,500 (40.5)	10,450 (56)	10,800 (62.5)
20		8,870 (32)	8,800 (51.5)	9,070 (59.5)
22		7,610 (20)	7,550 (46.5)	7,760 (56)
22.5		7,350 (0)	7,290 (45.5)	7,480 (55)
24			6,580 (41.5)	6,740 (52.5)
26			5,790 (35.5)	5,930 (48.5)
28			5,140 (28)	5,260 (44.5)
30			4,610 (17)	4,690 (40)
30.5			4,490 (0)	4,570 (39)
32				4,220 (35)
34				3,810 (29.5)
36				3,450 (21.5)
37.5				3,220 (0)

Feet	Main Boom Length in Feet			
	18	26	34	41
6	30,000 (66)			
8	27,150 (58.5)	19,800 (69.5)		
10	24,000 (50)	19,800 (64.5)		
12	21,500 (39.5)	18,950 (59.5)	17,350 (67.5)	
14	18,500 (24.5)	16,700 (53.5)	15,150 (64)	13,550 (69)
14.5	13,800 (0)	16,250 (52)	14,750 (63)	13,200 (68)
16		14,900 (47.5)	13,600 (60)	12,200 (66)
18		13,200 (40.5)	12,300 (56)	11,000 (62.5)
20		11,100 (32)	10,900 (51.5)	10,100 (59.5)
22		9,560 (20)	9,390 (46.5)	9,320 (56)
22.5		8,960 (0)	9,070 (45.5)	9,140 (55)
24			8,210 (41.5)	8,360 (52.5)
26			7,280 (35.5)	7,350 (48.5)
28			6,510 (28)	6,530 (44.5)
30			5,880 (17)	5,860 (40)
30.5			5,740 (0)	5,710 (39)
32				5,290 (35)
34				4,790 (29.5)
36				4,370 (21.5)
37.5				4,090 (0)

*NOTE: () Boom angles are in degrees.

THIS CHART IS ONLY A GUIDE AND SHOULD NOT BE USED TO OPERATE THE CRANE.

The individual crane's load chart, operating instructions and other instructional plates must be read and understood prior to operating the crane

LOAD CHART

41 ft Boom - Imperial 85%



15 ft



100%



360°



Pounds

Feet	15 ft Length		
	0° OFFSET	15° OFFSET	30° OFFSET
18	7,370 (70)		
20	7,210 (68)		
22	6,650 (65.5)	4,790 (69.5)	
24	6,020 (63.5)	4,570 (67)	3,650 (70)
26	5,590 (61)	4,290 (64.5)	3,520 (67.5)
28	5,290 (58.5)	4,120 (62)	3,410 (65)
30	4,810 (56)	3,900 (59.5)	3,290 (62.5)
32	4,350 (53.5)	3,770 (57)	3,200 (60)
34	3,950 (51)	3,600 (54.5)	3,120 (57)
36	3,600 (48)	3,450 (51.5)	3,030 (54)
38	3,300 (45)	3,330 (48.5)	2,970 (51)
40	3,040 (42)	3,080 (45.5)	2,910 (47.5)
42	2,800 (38.5)	2,840 (42)	2,850 (44)
44	2,590 (35)	2,620 (38.5)	2,680 (40)
46	2,400 (31)	2,430 (34.5)	2,480 (35.5)
48	2,230 (26)	2,250 (29.5)	
50	2,070 (20.5)	2,090 (23)	
52	1,930 (11.5)		
52.5	1,890 (6.5)		

NOTES:

1. 15 ft boom extension may be used for single line lifting service only.
2. WARNING: Operation of this machine with heavier loads than the capacities listed is strictly prohibited. Machine tipping with boom extension occurs rapidly and without advance warning.

* Boom length noted represents range of similar lengths.

THIS CHART IS ONLY A GUIDE AND SHOULD NOT BE USED TO OPERATE THE CRANE.

The individual crane's load chart, operating instructions and other instructional plates must be read and understood prior to operating the crane

LOAD CHART

41 ft Boom - Imperial 85%



18 ft –
41 ft



Stationary



Defined Arc
Over Front



Stationary



360°



Pick &
Carry



Over Front



Pounds

Radius in Feet	Defined Arc 8° Over Front	Stationary 360°
6	19,300	14,450
8	15,600	11,100
10	12,950	8,940
12	10,100	7,290
14	7,780	5,720
14.5	7,340	5,400
16	6,440	4,700
18	5,340	3,890
20	4,520	3,270
22	3,870	2,780
22.5	3,730	2,670
24	3,390	2,460
26	2,960	2,140
28	2,600	1,870
30	2,300	1,640
30.5	2,230	1,590
32	2,100	1,450
34	1,870	1,280
36	1,670	1,130
37.5	1,540	1,030

NOTES:

1. Capacities are in pounds and do not exceed 75% of tipping loads as determined by test in accordance with SAE J765.
2. Capacities are applicable to machines equipped with outrigger R4 385/65 D22.5 at 125 psi cold inflation pressure.
3. Capacities are applicable only with machine on a smooth, level and firm surface.
4. Defined Arc – Over front includes 8° on either side of longitudinal centerline of machine.
5. All rubber lifting depends on proper tire inflation, capacity and condition. Capacities must be reduced for lower tire inflation pressures. Damaged tires are hazardous to safe operation of crane.
6. For pick and carry operation, the boom, using the shortest practical boom length, must be centered over front of machine. Maximum speed is 2.5 mph.
7. On rubber lifting with boom extension not permitted.

* Boom length noted represents range of similar lengths.

THIS CHART IS ONLY A GUIDE AND SHOULD NOT BE USED TO OPERATE THE CRANE.

The individual crane's load chart, operating instructions and other instructional plates must be read and understood prior to operating the crane

WORKING RANGE

50 ft Boom - Imperial 85%

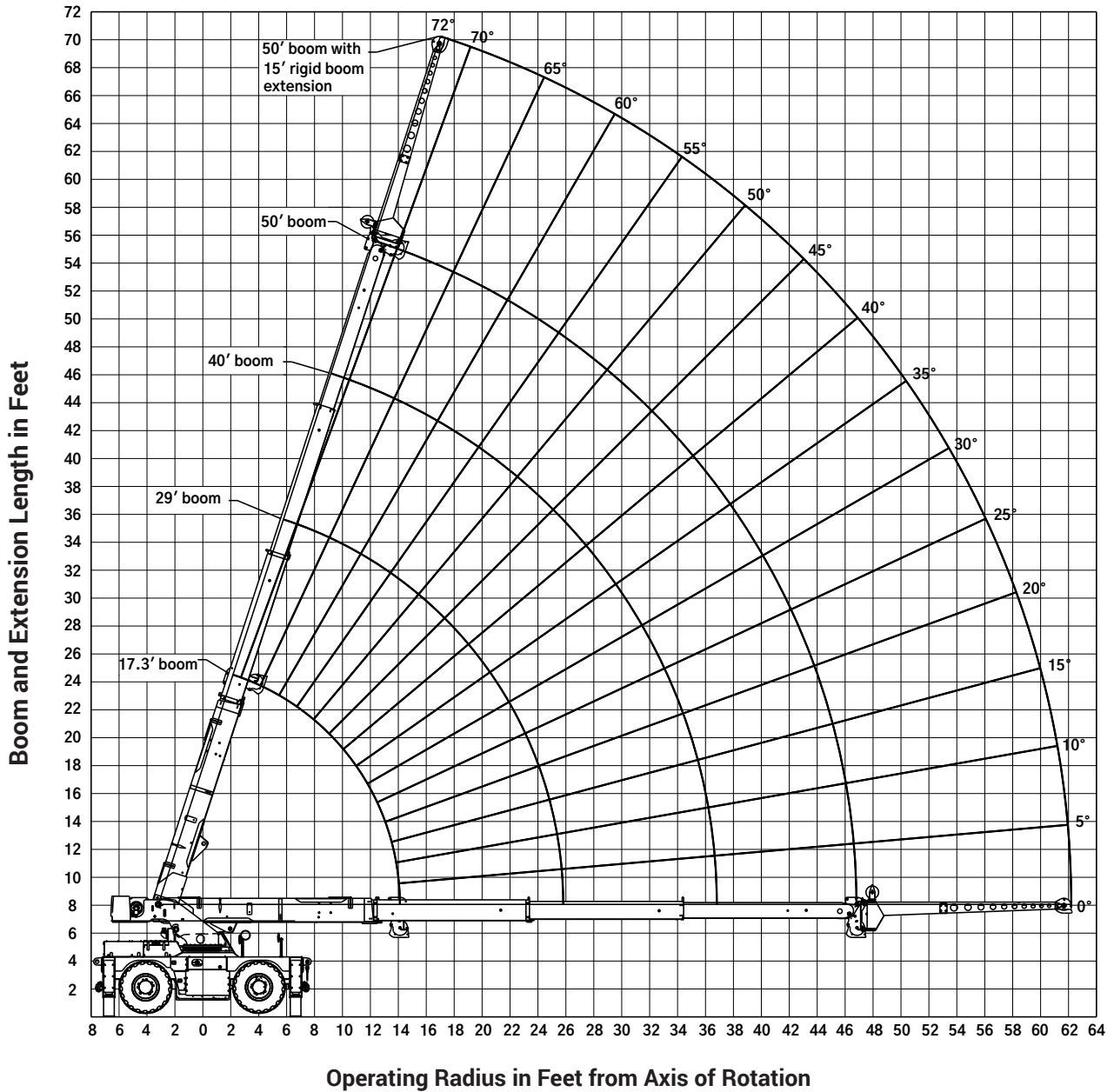

THIS CHART IS ONLY A GUIDE AND SHOULD NOT BE USED TO OPERATE THE CRANE.
The individual crane's load chart, operating instructions and other instructional plates must be read and understood prior to operating the crane

LOAD CHART

50 ft Boom - Imperial 85%



Pounds

Feet	Main Boom Length in Feet			
	17.3	29	40	50
6	30,000 (64.5)			
8	25,750 (56.5)			
10	21,250 (47)	6,950 (67)		
12	18,050 (35.5)	16,950 (62.5)		
14	13,100 (0)	15,700 (58)	14,950 (68.5)	
16		12,300 (53)	12,550 (65)	
18		10,050 (48)	10,200 (62)	10,150 (68.5)
20		8,470 (42.5)	8,550 (58.5)	8,500 (65.5)
22		7,240 (35)	7,300 (55)	7,260 (63)
24		6,290 (26)	6,330 (51.5)	6,300 (60.5)
25.5		5,700 (0)	5,730 (48.5)	5,710 (58.5)
26			5,550 (47.5)	5,530 (57.5)
28			4,910 (43)	4,900 (55)
30			4,380 (38.5)	4,370 (52)
32			3,920 (33)	3,930 (48.5)
34			3,530 (26)	3,550 (45.5)
36			3,190 (16.5)	3,220 (42)
36.5			3,110 (0)	3,140 (41)
38				2,930 (38)
40				2,670 (34)
42				2,440 (29)
44				2,230 (23)
46				2,040 (14)
46.5				2,000 (0)

Feet	Main Boom Length in Feet			
	17.3	29	40	50
6	30,000 (64.5)			
8	25,750 (56.5)			
10	21,250 (47)	16,950 (67)		
12	18,050 (35.5)	16,950 (62.5)		
14	13,100 (0)	16,400 (58)	14,950 (68.5)	
16		14,950 (53)	13,700 (65)	
18		13,550 (48)	12,500 (62)	12,150 (68.5)
20		11,200 (42.5)	10,850 (58.5)	10,900 (65.5)
22		9,480 (35)	9,220 (55)	9,250 (63)
24		8,140 (26)	7,970 (51.5)	7,980 (60.5)
25.5		7,150 (0)	7,210 (48.5)	7,210 (58.5)
26			6,980 (47.5)	6,980 (57.5)
28			6,180 (43)	6,170 (55)
30			5,520 (38.5)	5,500 (52)
32			4,970 (33)	4,940 (48.5)
34			4,490 (26)	4,460 (45.5)
36			4,070 (16.5)	4,050 (42)
36.5			3,980 (0)	3,960 (41)
38				3,690 (38)
40				3,380 (34)
42				3,090 (29)
44				2,840 (23)
46				2,610 (14)
46.5				2,560 (0)

*NOTE: () Boom angles are in degrees.

THIS CHART IS ONLY A GUIDE AND SHOULD NOT BE USED TO OPERATE THE CRANE.

The individual crane's load chart, operating instructions and other instructional plates must be read and understood prior to operating the crane

LOAD CHART

50 ft Boom - Imperial 85%



15 ft

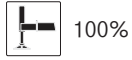

100%



360°



Pounds

Feet	15 ft Length		
	0° OFFSET	15° OFFSET	30° OFFSET
20	7,020 (71.5)		
22	6,200 (69.5)		
24	5,670 (67.5)	4,980 (71.5)	
26	5,250 (65.5)	4,680 (69)	3,720 (71.5)
28	5,000 (63.5)	4,520 (67)	3,600 (69.5)
30	4,660 (61.5)	4,210 (65)	3,500 (67.5)
32	4,180 (59.5)	3,940 (62.5)	3,410 (65.5)
34	3,770 (57.5)	3,800 (60.5)	3,320 (63)
36	3,420 (55)	3,490 (58.5)	3,230 (61)
38	3,110 (53)	3,150 (56)	3,160 (58.5)
40	2,830 (50.5)	2,860 (54)	2,970 (56)
42	2,590 (48)	2,600 (51.5)	2,690 (53.5)
44	2,370 (45.5)	2,360 (49)	2,450 (51)
46	2,180 (43)	2,150 (46)	2,230 (48.5)
48	2,000 (40)	1,960 (43.5)	2,030 (45.5)
50	1,840 (37)	1,790 (40.5)	1,850 (42)
52	1,690 (34)	1,630 (37)	1,680 (38.5)
54	1,560 (30.5)	1,480 (33.5)	1,530 (34.5)
56	1,430 (26.5)	1,350 (29.5)	1,390 (30)
58	1,320 (21.5)	1,230 (24)	
60	1,210 (15)	1,110 (17)	
61.5	1,140 (6)		

NOTES:

1. 15 ft boom extension may be used for single line lifting service only.
2. WARNING: Operation of this machine with heavier loads than the capacities listed is strictly prohibited. Machine tipping with boom extension occurs rapidly and without advance warning.

THIS CHART IS ONLY A GUIDE AND SHOULD NOT BE USED TO OPERATE THE CRANE.

The individual crane's load chart, operating instructions and other instructional plates must be read and understood prior to operating the crane

LOAD CHART

41 ft Boom - Imperial 85%



17 ft -
50 ft



Stationary



Defined Arc
Over Front



Stationary



360°



Pick &
Carry



Over Front



Pounds

Radius in Feet	Defined Arc 8° Over Front	Stationary 360°
6	16,000	12,000
8	13,600	9,900
10	11,700	8,490
12	9,820	7,220
14	7,410	5,540
16	6,520	4,650
18	5,340	3,800
20	4,460	3,160
22	3,770	2,650
24	3,220	2,240
25.5	2,870	1,980
26	2,850	1,960
28	2,470	1,720
30	2,140	1,470
32	1,870	1,260
34	1,620	1,080
36	1,410	910
36.5	1,360	880
38	1,320	780
40	1,150	650
42	1,000	540
44	870	430
46	750	340
46.5	720	320

NOTES:

1. Capacities are in pounds and do not exceed 75% of tipping loads as determined by test in accordance with SAE J765.
2. Capacities are applicable to machines equipped with outrigger R4 385/65 D22.5 at 125 psi cold inflation pressure.
3. Capacities are applicable only with machine on a smooth, level and firm surface.
4. Defined Arc – Over front includes 8° on either side of longitudinal centerline of machine.
5. All rubber lifting depends on proper tire inflation, capacity and condition. Capacities must be reduced for lower tire inflation pressures. Damaged tires are hazardous to safe operation of crane.
6. For pick and carry operation, the boom, using the shortest practical boom length, must be centered over front of machine. Maximum speed is 2.5 mph.
7. On rubber lifting with boom extension not permitted.

* Boom length noted represents range of similar lengths.

THIS CHART IS ONLY A GUIDE AND SHOULD NOT BE USED TO OPERATE THE CRANE.

The individual crane's load chart, operating instructions and other instructional plates must be read and understood prior to operating the crane

WORKING RANGE

12,5 m Boom - Metric 85%

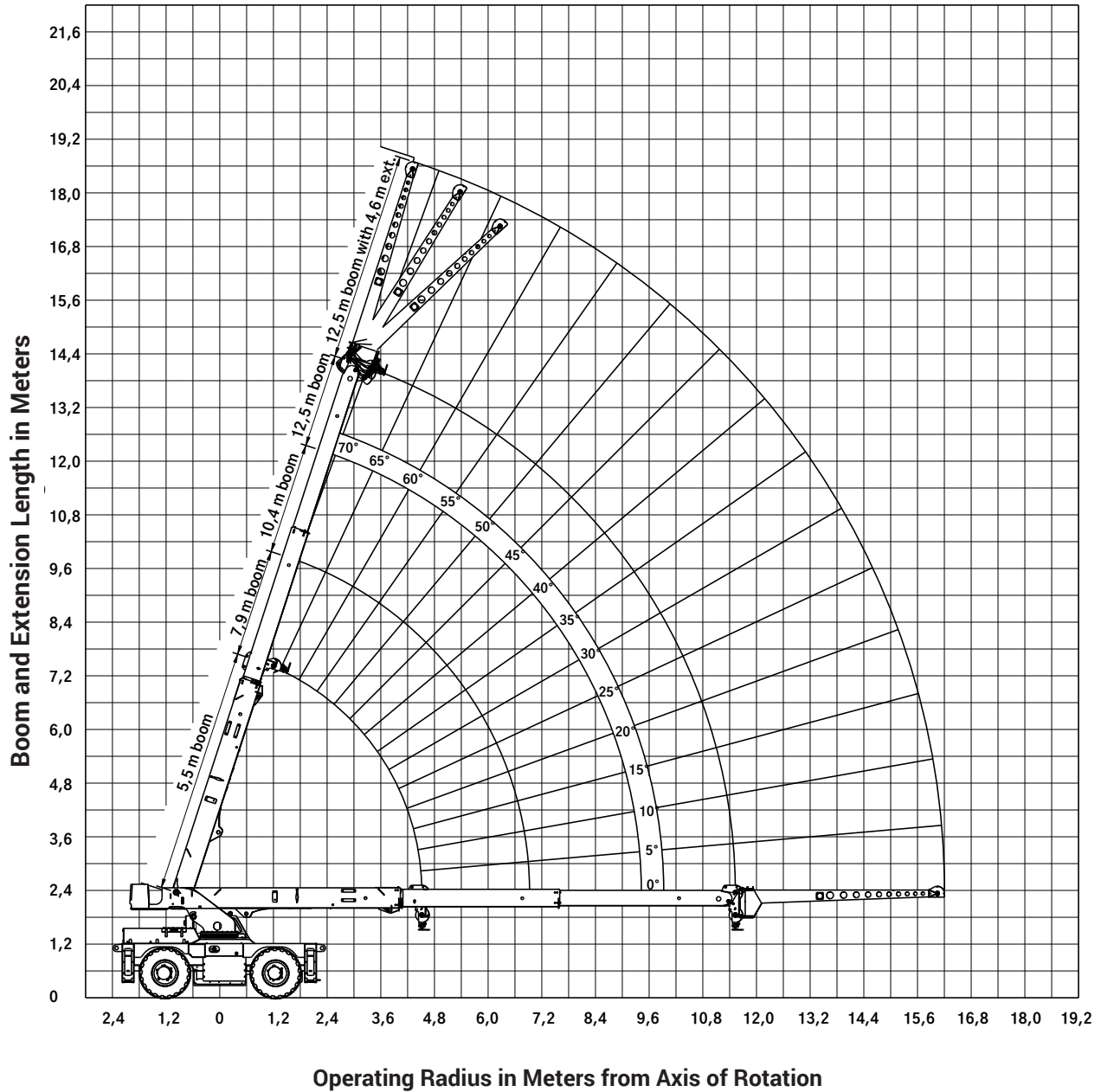

THIS CHART IS ONLY A GUIDE AND SHOULD NOT BE USED TO OPERATE THE CRANE.
The individual crane's load chart, operating instructions and other instructional plates must be read and understood prior to operating the crane

LOAD CHART

12,5 m Boom - Metric 85%



5,5 m – 12,5 m



100%



360°



5,5 m – 12,5 m



100%



Over front



Kilograms

Meters	Main Boom Length in Meters			
	5,5	7,9	10,4	12,5
1,8	13 600 (66,5)			
2,4	12 300 (59)	8980 (70)		
3,0	10 875 (50,5)	8980 (65)		
3,7	9750 (38,5)	8595 (59)	7870 (67,5)	
4,3	7160 (23,5)	7300 (53,5)	6870 (63,5)	6145 (68,5)
4,4	6260 (0)	7000 (52,5)	6690 (63)	5985 (68)
4,9		5785 (47,5)	5750 (60)	5530 (65,5)
5,5		4760 (40,5)	4725 (55,5)	4885 (62,5)
6,1		4015 (32)	3985 (51,5)	4110 (59,5)
6,7		3455 (20)	3430 (46,5)	3525 (56)
6,9		3300 (0)	3275 (45)	3360 (55)
7,3			2995 (41,5)	3070 (52,5)
7,9			2640 (35,5)	2700 (49)
8,5			2350 (28,5)	2400 (45)
9,1			2105 (18,5)	2145 (40,5)
9,3			2035 (0)	2070 (39)
9,8				1895 (35)
10,4				1715 (29)
11,0				1560 (21)
11,4				1465 (0)

Meters	Main Boom Length in Meters			
	5,5	7,9	10,4	12,5
1,8	13 600 (66,5)			
2,4	12 300 (59)	8980 (70)		
3,0	10 875 (50,5)	8980 (65)		
3,7	9750 (38,5)	8595 (59)	7870 (67,5)	
4,3	8390 (23,5)	7575 (53,5)	6870 (63,5)	6145 (68,5)
4,4	6260 (0)	7370 (52,5)	6690 (63)	5985 (68)
4,9		6755 (47,5)	6165 (60)	5530 (65,5)
5,5		5980 (40,5)	5575 (55,5)	4990 (62,5)
6,1		5040 (32)	4950 (51,5)	4580 (59,5)
6,7		4345 (20)	4265 (46,5)	4225 (56)
6,9		4060 (0)	4075 (45)	4145 (55)
7,3			3735 (41,5)	3805 (52,5)
7,9			3315 (35,5)	3350 (49)
8,5			2970 (28,5)	2980 (45)
9,1			2685 (18,5)	2675 (40,5)
9,3			2600 (0)	2585 (39)
9,8				2380 (35)
10,4				2165 (29)
11,0				1975 (21)
11,4				1865 (0)

*NOTE: () Boom angles are in degrees.

THIS CHART IS ONLY A GUIDE AND SHOULD NOT BE USED TO OPERATE THE CRANE.

The individual crane's load chart, operating instructions and other instructional plates must be read and understood prior to operating the crane

LOAD CHART

12,5 m Boom - Metric 85%



4,6 m



100%



360°



Kilograms

Meters	4,6 m Length		
	0° OFFSET	15° OFFSET	30° OFFSET
5,5	3340 (70)		
6,1	3270 (68)		
6,7	3015 (66)	2170 (69,5)	
7,3	2730 (63,5)	2070 (67)	1655 (70)
7,9	2535 (61)	1945 (64,5)	1595 (67,5)
8,5	2400 (58,5)	1865 (62,5)	1545 (65)
9,1	2200 (56,5)	1765 (60)	1490 (62,5)
9,8	1955 (53,5)	1710 (57)	1450 (59,5)
10,4	1780 (50,5)	1630 (54,5)	1415 (57)
11,0	1630 (48)	1565 (51,5)	1370 (54)
11,6	1495 (45)	1510 (48,5)	1,345 (51)
12,2	1375 (42)	1395 (45,5)	1,320 (47,5)
12,8	1270 (38,5)	1285 (42)	1290 (44)
13,4	1175 (35)	1190 (38,5)	1,220 (40)
14,0	1090 (31)	1105 (34,5)	1125 (35,5)
14,6	1015 (26,5)	1025 (29,5)	
15,2	945 (21)	955 (23,5)	
15,8	880 (12,5)		
16,0	860 (6,5)		

NOTES:

1. 4,6 m boom extension may be used for single line lifting service only.
2. WARNING: Operation of this machine with heavier loads than the capacities listed is strictly prohibited. Machine tipping with boom extension occurs rapidly and without advance warning.

THIS CHART IS ONLY A GUIDE AND SHOULD NOT BE USED TO OPERATE THE CRANE.

The individual crane's load chart, operating instructions and other instructional plates must be read and understood prior to operating the crane

LOAD CHART

12,5 m Boom - Metric 85%



Radius in Meters	Defined Arc 8° Over Front	Stationary 360°
1,8	8765	6570
2,4	7075	5045
3,0	5870	4055
3,7	4495	3250
4,3	3485	2565
4,4	3355	2465
4,9	2900	2115
5,5	2415	1760
6,1	2045	1480
6,7	1760	1260
6,9	1675	1195
7,3	1540	1120
7,9	1350	975
8,5	1190	855
9,1	1050	755
9,3	1010	720
9,8	945	650
10,4	845	575
11,0	755	510
11,4	700	470

NOTES:

1. Capacities are in pounds and do not exceed 75% of tipping loads as determined by test in accordance with SAE J765.
2. Capacities are applicable to machines equipped with outrigger R4 385/65 D22.5 at 8,6 bar cold inflation pressure.
3. Capacities are applicable only with machine on a smooth, level and firm surface.
4. Defined Arc – Over front includes 8° on either side of longitudinal centerline of machine.
5. All rubber lifting depends on proper tire inflation, capacity and condition. Capacities must be reduced for lower tire inflation pressures. Damaged tires are hazardous to safe operation of crane.
6. For pick and carry operation, the boom, using the shortest practical boom length, must be centered over front of machine. Maximum speed is 4,0 kmh.
7. On rubber lifting with boom extension not permitted.

THIS CHART IS ONLY A GUIDE AND SHOULD NOT BE USED TO OPERATE THE CRANE.

The individual crane's load chart, operating instructions and other instructional plates must be read and understood prior to operating the crane

WORKING RANGE

15,2 m Boom - Metric 85%

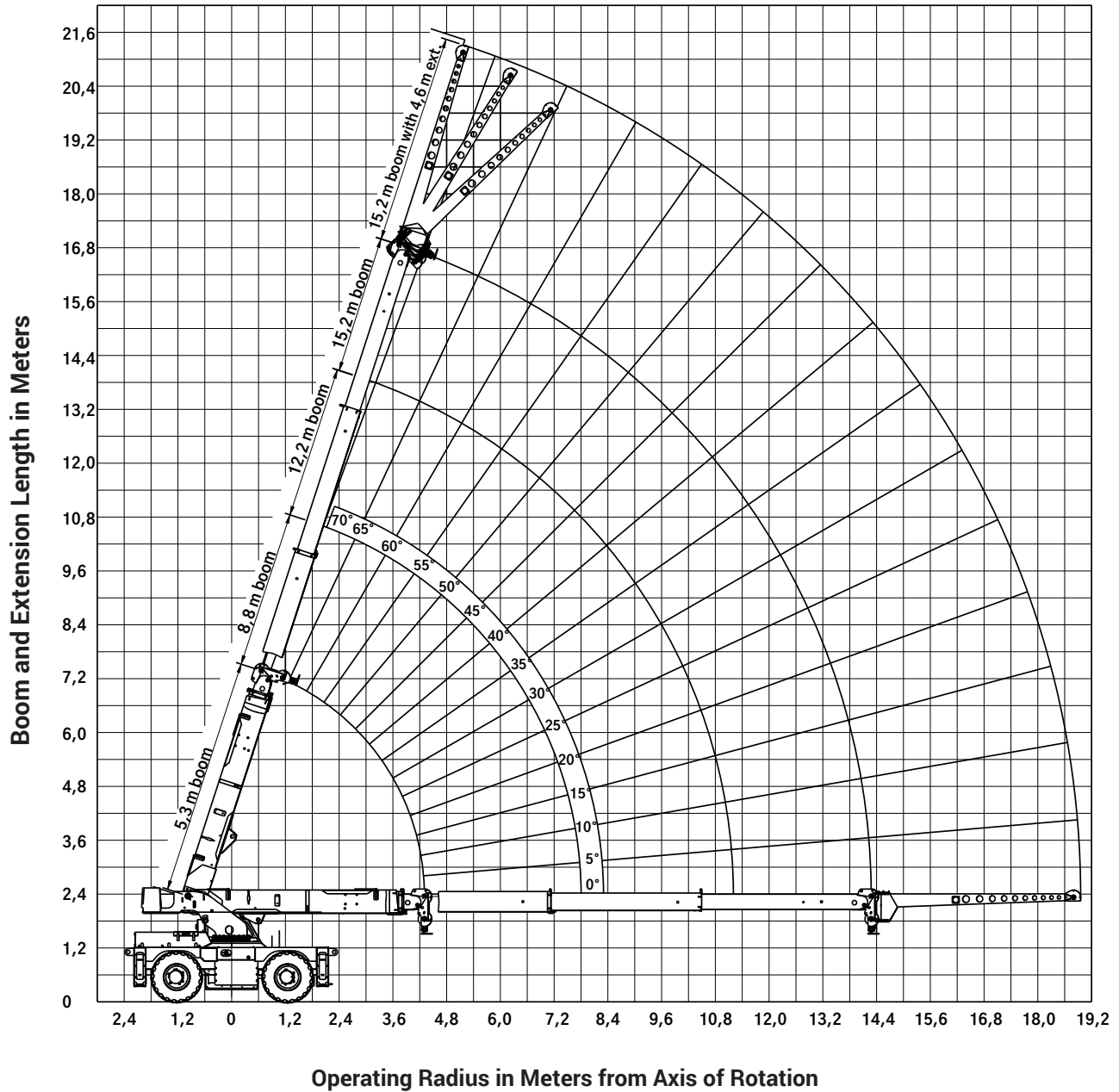

THIS CHART IS ONLY A GUIDE AND SHOULD NOT BE USED TO OPERATE THE CRANE.
The individual crane's load chart, operating instructions and other instructional plates must be read and understood prior to operating the crane

LOAD CHART

15,2 m Boom - Metric 85%



5,3 m – 15,2 m



100%



360°



5,3 m – 15,2 m



100%



Over front



Kilograms

Meters	Main Boom Length in Meters			
	5,3	8,8	12,2	15,2
1,8	13 600 (65)			
2,4	11 675 (57)			
3,0	9635 (48)	7685 (67,5)		
3,7	8040 (34,5)	7685 (62,5)		
4,3	5920 (0)	7030 (57,5)	6780 (68)	
4,9		5550 (52,5)	5645 (65)	
5,5		4550 (47,5)	4615 (62)	4585 (68)
6,1		3835 (42)	3875 (58,5)	3850 (65,5)
6,7		3290 (35)	3315 (55)	3300 (63)
7,3		2860 (26)	2880 (51,5)	2865 (60,5)
7,8		2570 (0)	2585 (48)	2575 (58)
7,9			2530 (47,5)	2520 (58)
8,5			2245 (43,5)	2235 (55)
9,1			2000 (39)	2000 (52)
9,8			1765 (32,5)	1770 (48,5)
10,4			1590 (25,5)	1600 (45)
11,0			1440 (15,5)	1455 (42)
11,1			1420 (0)	1430 (41)
11,6				1325 (38)
12,2				1210 (34)
12,8				1105 (29)
13,4				1015 (23)
14,0				930 (14,5)
14,2				905 (0)

Meters	Main Boom Length in Meters			
	5,3	8,8	12,2	15,2
1,8	13 600 (65)			
2,4	11 675 (57)			
3,0	9635 (48)	7685 (67,5)		
3,7	8185 (34,5)	7685 (62,5)		
4,3	5940 (0)	7435 (57,5)	6780 (68)	
4,9		6780 (52,5)	6210 (65)	
5,5		6140 (47,5)	5670 (62)	5510 (68)
6,1		5085 (42)	4920 (58,5)	4940 (65,5)
6,7		4305 (35)	4190 (55)	4200 (63)
7,3		3705 (26)	3630 (51,5)	3635 (60,5)
7,8		3240 (0)	3250 (48)	3250 (58)
7,9			3185 (47,5)	3185 (58)
8,5			2825 (43,5)	2820 (55)
9,1			2525 (39)	2515 (52)
9,8			2235 (32,5)	2225 (48,5)
10,4			2025 (25,5)	2015 (45)
11,0			1840 (15,5)	1830 (42)
11,1			1810 (0)	1800 (41)
11,6				1670 (38)
12,2				1530 (34)
12,8				1405 (29)
13,4				1290 (23)
14,0				1190 (14,5)
14,2				1155 (0)

*NOTE: () Boom angles are in degrees.

THIS CHART IS ONLY A GUIDE AND SHOULD NOT BE USED TO OPERATE THE CRANE.

The individual crane's load chart, operating instructions and other instructional plates must be read and understood prior to operating the crane

LOAD CHART

15,2 m Boom - Metric 85%



4,6 m



100%



360°



Kilograms

Meters	4,6 m Length		
	0° OFFSET	15° OFFSET	30° OFFSET
6,1	3180 (71,5)		
6,7	2810 (69,5)		
7,3	2570 (67,5)	2255 (71)	
7,9	2380 (65,5)	2120 (69)	1685 (72)
8,5	2265 (63,5)	2050 (67)	1630 (70)
9,1	2130 (61,5)	1910 (65)	1585 (67,5)
9,8	1885 (59,5)	1785 (62,5)	1545 (65,5)
10,4	1700 (57)	1720 (60,5)	1505 (63)
11,0	1545 (55)	1575 (58,5)	1465 (61)
11,6	1405 (53)	1425 (56)	1430 (58,5)
12,2	1285 (50,5)	1295 (54)	1345 (56)
12,8	1175 (48)	1180 (51,5)	1220 (53,5)
13,4	1080 (45,5)	1075 (49)	1115 (51)
14,0	990 (43)	980 (46,5)	1015 (48,5)
14,6	910 (40,5)	895 (43,5)	925 (45,5)
15,2	840 (37,5)	815 (40,5)	845 (42,5)
15,8	770 (34)	745 (37,5)	770 (39)
16,5	700 (30)	670 (33)	690 (34,5)
17,1	645 (26)	610 (29)	630 (30)
17,7	595 (21,5)	555 (24)	
18,3	550 (15)	505 (17)	
18,7	520 (7,5)		

NOTES:

1. 4,6 m boom extension may be used for single line lifting service only.
2. WARNING: Operation of this machine with heavier loads than the capacities listed is strictly prohibited. Machine tipping with boom extension occurs rapidly and without advance warning.

THIS CHART IS ONLY A GUIDE AND SHOULD NOT BE USED TO OPERATE THE CRANE.

The individual crane's load chart, operating instructions and other instructional plates must be read and understood prior to operating the crane

LOAD CHART

15,2 m Boom - Metric 85%



5,3 m –
15,2 m



Stationary



Defined Arc
Over Front



Stationary



360°



Pick &
Carry



Over Front



Kilograms

Radius in Meters	Defined Arc 8° Over Front	Stationary 360°
1,8	7255	5445
2,4	6165	4490
3,0	5310	3850
3,7	4360	3210
4,3	3315	2480
4,9	2935	2095
5,5	2415	1715
6,1	2020	1430
6,7	1715	1205
7,3	1465	1020
7,8	1295	890
7,9	1285	880
8,5	1130	785
9,1	985	675
9,8	835	565
10,4	730	485
11,0	635	410
11,1	620	400
11,6	595	350
12,2	520	295
12,8	455	245
13,4	395	195
14,0	340	155
14,2	325	140

NOTES:

1. Capacities are in pounds and do not exceed 75% of tipping loads as determined by test in accordance with SAE J765.
2. Capacities are applicable to machines equipped with outrigger R4 385/65 D22.5 at 8,6 bar cold inflation pressure.
3. Capacities are applicable only with machine on a smooth, level and firm surface.
4. Defined Arc – Over front includes 8° on either side of longitudinal centerline of machine.
5. All rubber lifting depends on proper tire inflation, capacity and condition. Capacities must be reduced for lower tire inflation pressures. Damaged tires are hazardous to safe operation of crane.
6. For pick and carry operation, the boom, using the shortest practical boom length, must be centered over front of machine. Maximum speed is 4,0 kmh.
7. On rubber lifting with boom extension not permitted.

THIS CHART IS ONLY A GUIDE AND SHOULD NOT BE USED TO OPERATE THE CRANE.

The individual crane's load chart, operating instructions and other instructional plates must be read and understood prior to operating the crane

TRANSPORTATION & LIFTING

1. Lifting of entire crane or major crane assemblies must be accomplished by utilizing specific fittings indicated on adjacent chart. Use of fittings for purposes other than those designated on chart is prohibited. Fitting capacities are maximum allowable loads per individual fitting.
2. Rigging personnel shall be responsible for proper selection and placement of all slings and load handling devices.
3. Dimensions and weights shown are estimated for largest configuration available. Weights do not include boom extension and/or jib, unless otherwise indicated.
4. Rigging personnel shall verify dimensions as required for clearance.
5. Do not use counterweight lift locations or boom sling point for lifting or tie down of entire crane.
6. Lifting of counterweight to be accomplished with a properly rated 1 1/4"-7 UNC fittings.

FITTING	NO. / UNIT	LIFT	TOW	TIE DOWN	BOOM	CWT	CAPACITY TONS						
							LIFT	LIFT	LIFT	TOW	TIE DOWN		
											FORE & AFT	SIDE	DOWN
A	4	X	X	X			28 (25,4)	28 (25,4)	28 (25,4)	8 (7,3)	28 (25,4)		
B	4				X		2 (1,8)						
C	2					X	1.9 (1,7)						

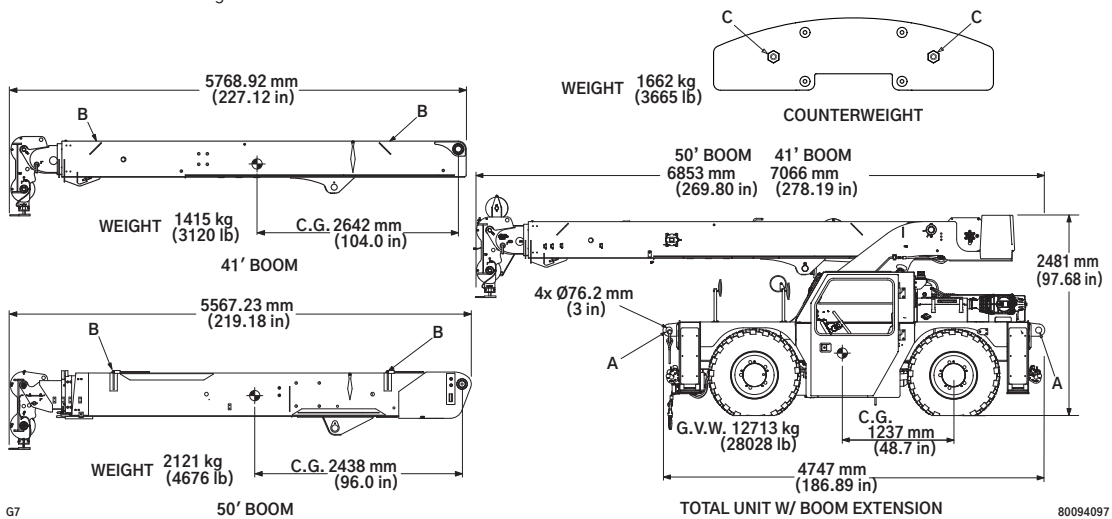

Load Distribution For Carrydeck

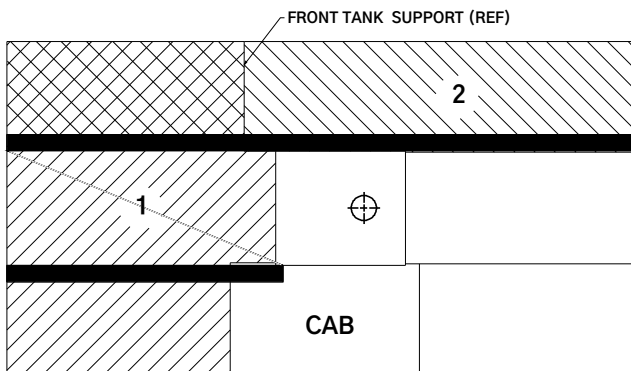

Maximum allowable uniformly distributed load:

- AREA 1**
8165 kg (18,000 lb)
- OR
- AREA 2**
5897 kg (13,000 lb)

1. Maximum travel speed with any or all loads – 2.5 mph (4,0 kmh)
2. Loads to be transported on smooth level firm surfaces only.
3. Boom must be retracted and in center forward position, and lowered as much as the load allows.
4. Pick and carry loads may be transported on either Deck Area 1 or Deck Area 2; combined loading of Deck Area 1 and Deck Area 2 not permitted.
5. Lifting is not permitted when carrydeck is loaded except for loading and unloading carrydeck.
6. The maximum pick and carry loads may be transported on deck area 1 provided the load is centered over the front axle and cribbed directly on the frame rails.

LOAD HANDLING

Weight Reductions for Load Handling Devices

15 ft (4,6 m) Fixed Offsettable Extension	
*Stowed	N/A
*Erected	650 lb (295 kg)
*Reduction of main boom capacities	
When lifting over swingaway and/or jib combinations, deduct total weight of all load handling devices reeved over main boom nose directly from swingaway or jib capacity.	

Hook Blocks And Headache Balls	
20 USt (18 t), two-sheave hook block	388 lb (176 kg)+
6.25 USt (5,7 t) downhaul weight	105 lb (48 kg)+
+Refer to rating plate for actual weight	
NOTE: All load handling devices and boom attachments are considered part of the load and suitable allowances MUST BE MADE for their combined weights. Weights are for Grove furnished equipment.	

Tire Inflation – Bar (PSI)		
Size (Front & Rear)	Ply Rating	Lifting Service, General Travel & Extended Travel
		Static & 2.5 MPH (4,0 Kmh)
OUTRIGGER R4 385/65 D22.5	16	125 (8,6)

Lifting Area Diagram

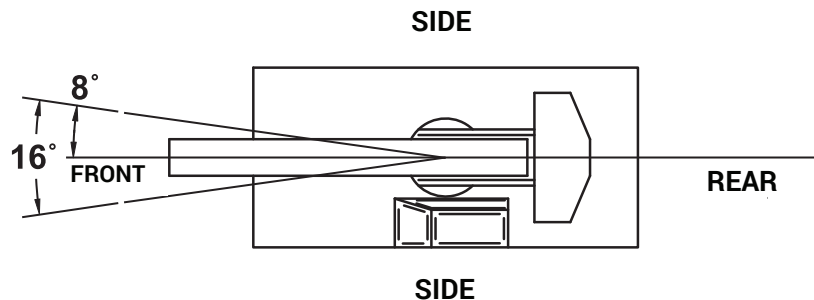

Line Pulls and Reeving Information

Hoists	Cable Specs.	Permissible Line Pulls	Nominal Cable Length
Main (41 ft boom)	9/16" (14 mm) 6x19 class Bridon EEIPS (XXIPS) Min. breaking strength 37,000 lb (16 780 kg)	8,500 lb (3856 kg)*	235 ft (72 m)
Main (50 ft boom)	9/16" (14 mm) 6x19 class Bridon EEIPS (XXIPS) Min. breaking strength 37,000 lb (16 780 kg)	8,500 lb (3856 kg)*	278 ft (84,7 m)

The approximate weight of 9/16" (14 mm) wire rope is 0.59 lb/ft (0,9 kg/m).

*With certain boom and hoist tackle combinations, the allowable line pull may be limited by hoist performance.

Refer to hoist performance table for lift planning to ensure adequate hoist performance on drum rope layer required.

SPECIFICATIONS

Superstructure



Boom

18 ft – 41 ft (5,5 m – 12,5 m) full-power main boom. Three-section boom with two (2) powered sections. Maximum tip height: 46.5 ft (14,2 m).



*Optional Boom

17.3 ft – 50 ft (5,3 m – 15,2 m) full-power main boom. Four-section boom with three (3) powered sections. Maximum tip height: 54 ft (16,5 m).



*Optional Swingaway Extension

15 ft (4,6 m) offsettable swingaway extension. Offsets 0°, 15° and 30° via pivoting boom nose. Stows alongside base boom section. Maximum tip height: 69.5 ft (21,18 m).



Boom Nose

Nylatron sheaves mounted on heavy-duty needle roller bearings with removable pin-type rope guards. Quick reeve type boom nose with three-position (0°, +40°, and +80°) pivoting to minimize head height requirements. Lowers head height by 1.3 ft (0,4 m).



Boom Elevation

Single double acting hydraulic cylinders with integral holding valves provides elevation from 0° to +72°.



Anti-two Block Device

Standard anti-two block device, which, when activated, provides an audible warning to the operator and “locks-out” all functions whose movement can cause two-blocking.



Rated Capacity Limiter (RCL)

Full-color, graphical display of boom angle, boom length, boom radius, rated load, and calculated load. Allows for operator inputs to set the crane configuration. RCL system is hardwired and calculates load via pressure transducers in the lift cylinder. Display includes a color-coded light bar and audible alarm with function cut-out if load exceeds the load chart parameters.



Swing

Ball bearing swing circle with 360° continuous rotation. Worm gear and pinion driven by hydraulic motor. Maximum speed: 2,0 rpm.



Hydraulic System

One pressure compensated variable displacement axial piston pump with load sensing.

Maximum output of: 34.5 gpm (130,6 lpm).

Maximum operating pressure: 3500 psi (241 bars).

Four-section valve bank, chassis mounted, operated via dash mounted, hydraulic pilot controls. 34.5 gal (130,6 L) hydraulic reservoir with sight level gauge and steel side plating to guard against side impacts.

5 micron return line filter with full flow by-pass protection and service indicator.



Hoist Specifications

Geroler motor driven with automatic spring-applied / hydraulically released wet brake. Drum rotation indicator in the hoist joystick control and hoist direction indicator light on dashboard.

- Maximum hoist pull (first layer): 9440 lb (4282 kg)
- Maximum permissible single line pull: 8500 lb (3856 kg) (3.5:1 design factor)
- Maximum single line speed: 117 fpm (35,66 m/min)
- Rope construction: 6X19 EEIPS/IWRC
- Rope diameter: 9/16 in (14 mm)
- Rope length: Main hoist 41 ft (12,5 m) boom: 235 ft (72 m); Main hoist: 50 ft (15,2 m) boom: 278 ft (84,7 m)
- Maximum rope stowage: Main hoist: 298 ft (90,83 m)

SPECIFICATIONS

Carrier



Chassis

High-strength alloy frame constructed with integral outrigger housings; front and rear lifting, tie-down, and towing lugs. 60 ft² (5,57 m²) carrydeck size with 18,000 lb (8165 kg) deck only carrying capacity. Deck coated with anti-skid treatment.



Outriggers

Hydraulically powered oblique-style single-stage outriggers that are independently controlled using the main control valve that provides 4 in (10,16 cm) of lift off the ground for leveling the crane. Outrigger cylinders have an integral holding valve. Outrigger pad size: 10.75 in x 16 in (27,3 cm x 40,64 cm). Maximum outrigger pad load: 30,000 lb (13 608 kg).



Outrigger Controls

Independent outrigger controls. 360° bubble level located inside cab.



Engine (EPA Tier 4F)

Cummins QSF 3.8L, four-cylinder / turbo-charged diesel rated at 74 hp (55.1 kW) at 2200 rpm. Standard 120 V engine block heater and cold weather intake grid heater. Engine hour meter located in dash display. Alternator 145 amp. Complies with EPA Tier 4 Final emissions standards without the use of an SCR or UREA injected DEF system. Maximum torque: 399,9 N-m (295 ft lb) at 1300 rpm. Note: Tier 4F engine required in North American countries. Fuel requirements: Maximum of 15 ppm ultra-low sulfur diesel fuel.



Engine (EPA Tier 3)

*Please consult factory for availability.

Cummins QSF 3.8L, four-cylinder / turbo-charged diesel rated at 74 kW (99 hp) at 2200 rpm. Standard 120 V engine block heater and cold weather intake grid heater. Engine hour meter located in dash display. Alternator 135 amp. Maximum torque: 420,3 Nm (310 ft/lb). Note: Required for sale outside of North American and European Union countries.



Engine (Dual Fuel)

GM 4.3L EFI V-6 gasoline 90 HP @ 2200 rpm / LP gas engine (07 EPA) 87 HP @ 2200 rpm (LP tank not included) with engine shutdown feature and spark arrestor.



Fuel Tank Capacity

26.4 gal (100 L)



Transmission

Powershift with four speeds forward and three speeds reverse. Stalk mounted direction shifter with rotary gear selection.



Operators Control Station

Frame mounted, open air style control station with cab shell includes all crane functions, driving controls, and overhead safety glass. Other standard equipment includes a deluxe seat with seat belt, hour meter, sight level bubble, and 2.5 lb (1,13 kg) fire extinguisher.

The dash panel includes a multi-cluster gauge showing fuel, water temperature, battery voltage and engine fault codes. An engine monitoring indicator lamp shows engine warning, stop engine, wait to start, transmission high temperature, low brake system pressure, and hydraulic oil temperature. The RCL display is mounted to the top of the front dash.



*Operators Control Station-Enclosed

Includes the standard cab shell with the addition of front, rear, and right side glass, a split (2 piece) hinged door with sliding glass, front windshield wiper and washer, hot water heater and defroster with fan and cab dome light are included.



Electrical system

One 12 V maintenance-free battery, 1125 CCA each at 0°. 135 amp alternator.



Drive

Two-wheel (front-wheel) as standard with four-wheel drive as an option. Drive axles supplied with planetary hubs and limited slip differential.



Steering

Standard three steering modes. Front two-wheel, four-wheel coordinated, and four-wheel crab steer with electronic self alignment, three-position rocker selector on dash panel.

Outside turning radius: Two-wheel steer: 17 ft 5.37 in (5,32 m); Four-wheel steer: 9 ft 4.44 in (2,86 m).

SPECIFICATIONS

Carrier (cont.)



Axles

Front: Drive/steer in both two-wheel drive and four-wheel drive. Rear: Non-drive with steer in two-wheel drive, drive/steer in four-wheel drive. Front and rear axle are rigid mounted to frame. Rear axle offers 1.5° of oscillation with four-wheel drive option only.



Brakes

Hydraulic actuated internal wet-disc service brake acting on all four wheels. Dash mounted toggle switch with light for activating or release of the dry disc parking brake mounted on the transmission output yoke.



Tires

Standard: 385/65R 22.5 High traction tread radial type tires.



Lights

Full lighting including turn indicators, head, tail, brake and hazard warning lights recessed mounted.



Maximum Speed

16 mph (25,75 km/h)



Gradeability (theoretical)

40% (at engine stall), loaded



Gross Vehicle Weight (GVW)

Open cab: 24,877 lb (11 285 kg); Enclosed cab: 25,160 lb (11 412 kg)

Miscellaneous Standard Equipment

- 20 USt (18,14 t) quick-reeve, two-sheave hook block
- Back-up motion alarm
- Outrigger motion alarm
- Hoist drum rotation indicator

* Optional equipment

- Auxiliary lighting: includes amber strobe light and boom mounted work lights
- Convenience package: includes front and rear pintle hitch and headlight/taillight grille covers
- Enclosed cab package: includes heater and defroster, cab dome light, all window glass, and two-piece split door
- Offsetable swing away boom extension with hook and downhaul weight
- Air conditioner
- Wire rope third wrap indicator with hoist function cut-out
- 10,000 lb (4535 kg) capacity hydraulic below-deck mounted tow winch
- Four-wheel drive with 1.5° rear axle oscillation
- Searcher hook
- Auxiliary hydraulic oil cooler
- Vertical light tower

SYMBOLS GLOSSARY



Axles



Chassis



Gross Vehicle Weight (GVW)



Rotation



Anti-Two Block Device



Counterweight



Hoist



Speed



Boom



Drive



Hydraulic System



Steering



Boom Elevation



Electrical System



Lights



Swing



Boom Extension



Engine



Outriggers



Tires



Boom Nose



Extension



Outrigger Controls



Transmission



Brakes



Fuel Tank Capacity



Radius



Cab



Gradeability



Rated Capacity Limiter (RCL)

The Manitowoc Company, Inc.

Regional headquarters

Americas

Milwaukee, Wisconsin, USA
Tel: +1 414 760 4600

Shady Grove, Pennsylvania, USA
Tel: +1 717 597 8121

Europe and Africa

Dardilly, France – TOWERS
Tel: +33 (0) 4 72 18 20 20

Wilhelmshaven, Germany – MOBILE
Tel: +49 (0) 4421 294 0

APAC

Shanghai, China
Tel: +86 21 6457 0066

Singapore
Tel: +65 6264 1188

Middle East and India

Dubai, UAE
Tel: +971 4 8862677

© 2026 The Manitowoc Company, Inc.
Form No. SCD15
Part No. 17-015/0326

This document is non-contractual. Constant improvement and engineering progress make it necessary that we reserve the right to make specification, equipment, and price changes without notice. Illustrations shown may include optional equipment and accessories and may not include all standard equipment.



[manitowoc.com](https://www.manitowoc.com)